

EDD

DRAWING NO.

42-1056

REV.

A

1. UNLESS OTHERWISE SPECIFIED TOLERANCES ARE $\pm .010$

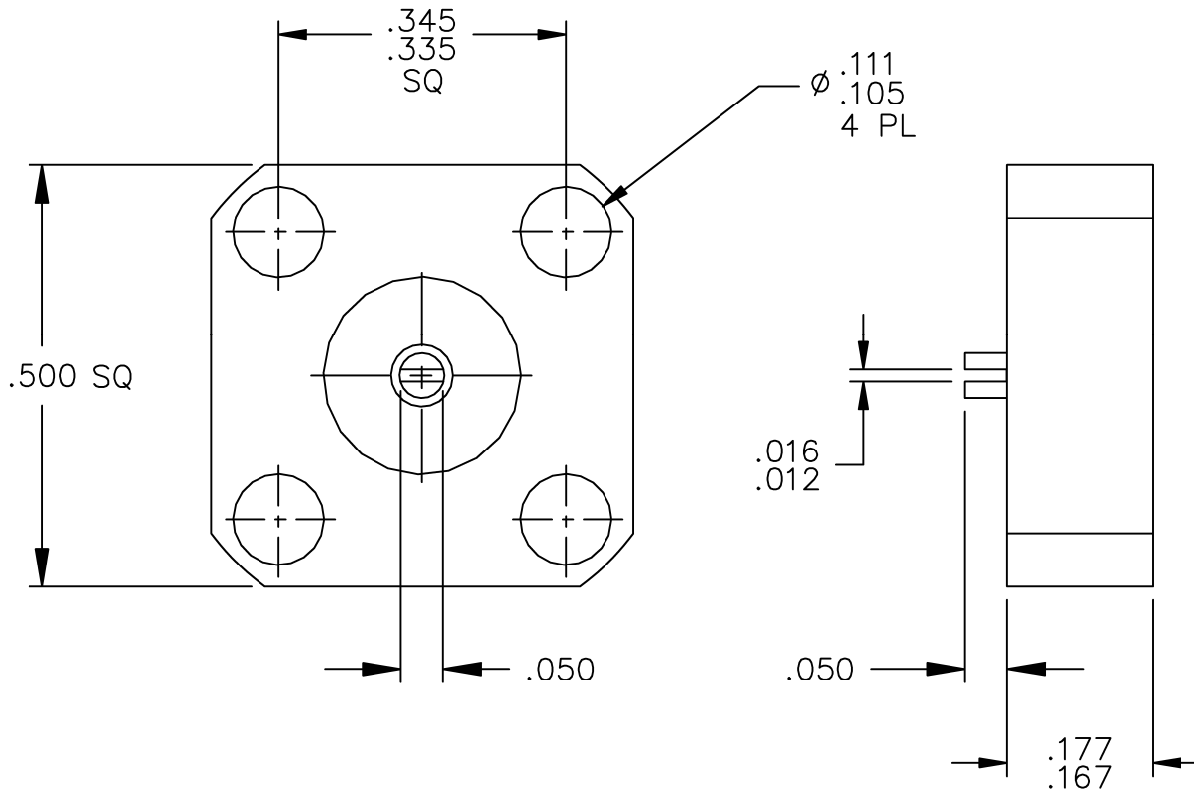

MATERIALS:

BODY: COPPER PER ASTM B301
 CONTACT: BERYLLIUM COPPER PER QQ-C-530
 INSULATOR: TEFLON PER MIL-P-19468
 SUBSTRATE: BERYLLIUM OXIDE
 RESISTIVE FILM: NICHROME

FINISH:

BODY: NICKEL PER QQ-N-290
 CONTACT: GOLD PER MIL-G-45204

A	08-F0808	9/08	
N/C	RLSE#02093	2/97	
REV.	DESCRIPTION	DATE	APPR.

UNLESS OTHERWISE SPECIFIED

- DIMENSIONS ARE AFTER PLATING
- DIAMETERS ON COMMON Q TO BE CONCENTRIC WITHIN T.I.R.
- SURFACE ROUGHNESS ✓
- CORNERS AND EDGES R. MAX.
- REMOVE BURRS AND BREAK SHARP EDGES

TOLERANCES

DECIMAL	FRACTION	ANGLES
.X \pm		
.XX \pm	\pm	\pm
.XXX \pm		

ALL DIMENSIONS ARE IN INCHES

REFERENCE		
MATERIAL		
FINISH		
SCALE	CAGE CODE ID NO.	SIZE
4X	2Y194	A
APPR.	CHK	



P.O. BOX 899
STUART, FL. 34995

TITLE

TERMINATION, FLANGE 20 WATT

DRAWING NO.	REV.
42-1056	A
DRAWN <u>PSC</u> 2/3/97	SHEET 1 OF 2

DRAWING NO.
42-1056

REV.
A

REQUIREMENTS	RATING	REQUIREMENTS	RATING
NOMINAL IMPEDANCE (OHMS)	50	VIBRATION	MIL-STD-202 METHOD 204 COND. D (20 G's)
FREQUENCY RANGE (GHz)	DC TO 18.0		
TEMPERATURE COEFFICIENT	LESS THAN 200 PPM	SHOCK	MIL-STD-202 METHOD 213 COND. 1 (100 G's)
TEMPERATURE RATING (°C)	-55 TO +125		
VSWR (MAXIMUM)	DC-4.0: 1.10:1	THERMAL SHOCK	MIL-STD-202 METHOD 107 COND. B (-65 TO +125 ° C)
	4.0-8.0: 1.15:1		
	8.0-12.0: 1.20:1		
	12.0-18.0: 1.30:1		
AVERAGE POWER (WATTS)	20	TERMINAL STRENGTH	2 LBS MINIMUM PULL
DC RESISTANCE	50 OHMS ± 5%	MOISTURE RESISTANCE	MIL-STD-202 METHOD 106 (LESS STEP 7B)
<p style="text-align: center;"><u>AVERAGE POWER DERATING</u></p>		SOLDERABILITY	MIL-STD-202 METHOD 208
		RESISTANCE TO SOLDER HEAT	MIL-STD-202 METHOD 210 COND. A

TITLE TERMINATION, FLANGE
20 WATT

FLORIDA
RF
Labs
INC.

P.O. BOX 899
STUART, FL. 34995

DRAWN PSC 02/03/97

SHEET 2 OF 2

DRAWING NO.
42-1056

REV.
A