

HBB - SINGLE POLE

WORKSHOP MANUAL

DO NOT DISCARD, DELIVER TO MANUFACTURING.
NO DESECHES, ENTREGA A LA FABRICACIÓN.
INSTRUCTIONS DE MONTAGE, NE PAS JETER.
BITTE NICHT WEGWERFEN, BITTE AN DIE PRODUCTION



REVISION HISTORY

			Compiled by	Title	Date
			<i>D. Bird</i>	Dan Bird Design Engineer	20.02.2014
			Checked by	Title	Date
			<i>I. Parry</i>	Ian Parry Chief Engineer, Platform Technologies, Rail & Auto EV	20.02.2014
			Approved by	Title	Date
			<i>I. Parry</i>	Ian Parry Chief Engineer, Platform Technologies, Rail & Auto EV	20.02.2014
A	20.02.14	-			
Revision	Date	C/N			

CONTENTS

<i>Section</i>	<i>Page no.</i>
1 SPECIAL TOOLS AND PROCESSES	5
1.1 CRIMP TOOLING	5
1.2 CRIMP DIES BY CODE/LUG AND CABLE SIZE – 300A RANGE	5
1.1 CRIMP DIES BY CODE/LUG AND CABLE SIZE – 500A RANGE	5
1.2 HEAT GUN FOR SHRINKING BOOTS AND SLEEVING	6
1.3 STRAP WRENCH	6
1.4 TORQUE WRENCH	6
1.5 FASTENER SPECIFICATION	6
1.6 TORQUE VALUE TABLE	6
2 CABLE PREPARATION	7
2.1 INSULATION STRIPPING LENGTHS	7
2.2 OUTER JACKET OF SCREENED CABLES, STRIPPING LENGTHS	8
3 CRIMPING STANDARD	8
3.1 TOOLING	8
3.2 PREPARATION – CONNECTOR ALIGNMENT	8
3.3 PREPARATION – ACCESSORY POSITIONING	8
3.4 CRIMPING SEQUENCE AND FINISHED DIMENSIONS – CONTACT BARRELS	9
3.5 CRIMPING SEQUENCE AND FINISHED DIMENSIONS – CABLE LUGS	9
3.6 DEBURRING AND FURTHER PREPARATION	10
4 CLEANING CABLE INSULATION	11
5 APPLYING HEAT SHRINK SLEEVING	11
5.1 APPLYING SLEEVING TO LUGS	11
5.2 APPLYING SLEEVING TO CONTACT BARRELS	11
6 SCREEN BRAIDS, TERMINATING	12
7 FITTING BOOTS	12
8 FITTING BACKSHELL CAPS	13
8.1 RIGHT ANGLE BACKSHELL-EQUIPPED CONNECTORS	13
9 PANEL PREPARATION FOR RECEPTACLES	14
9.1 STANDARD REAR MOUNT (CONNECTOR MOUNTED BEHIND PANEL/INSIDE BOX)	14
9.1.1 FRONT MOUNT (CONNECTOR MOUNTED IN FRONT OF PANEL / OUTSIDE BOX)	15
10 SEALING RECEPTACLES TO PANELS	15
10.1 STANDARD RECEPTACLES	15
10.2 FRONT MOUNT RECEPTACLE	15

11	LUG AND BUSBAR FASTENERS	15
12	FITTING AND TIGHTENING BACKSHELLS	16
	12.1 CHECK O-RING	16
	12.2 ATTACH BACKSHELL	17
	12.3 TIGHTEN BACKSHELL	17
13	CONNECTOR DIMENSIONS AND OUTLINE DRAWINGS	18
	13.1 300 AMP PLUG	18
	13.2 300 AMP REAR MOUNT RECEPTACLE	18
	13.3 300 AMP FRONT MOUNT RECEPTACLE	19
	13.4 300 AMP RECEPTACLE WITH STRAIGHT BACKSHELL, REAR MOUNT	19
	13.5 500 AMP PLUG	20
	13.6 500 AMP REAR MOUNT RECEPTACLE	20
	13.7 500 AMP FRONT MOUNT RECEPTACLE	21
	13.8 500 AMP RECEPTACLE WITH STRAIGHT BACKSHELL, REAR MOUNT	21
14	METAL BACKSHELL DIMENSIONS	22
	14.1 STRAIGHT OPTION	22
	14.2 RIGHT ANGLE OPTION	22
15	INDEX	23

LIST OF ILLUSTRATIONS

Page no.

Figure 1: Stripping lengths for connectors with crimp barrels 7

Figure 2: Finished right angle connector sectioned to show fully sealed cable 8

Figure 3: Crimp spacing and typical finished dimensions, contact barrels 9

Figure 4: Crimping dimensions for HBB-950 series lugs 10

Figure 5: Cable lug, sleeved ready for assembly to connector 11

Figure 6: Sleeving of crimp contacts 11

Figure 7: Position of heat shrink boot lips..... 12

Figure 8: Backshell cap ready for assembly 13

Figure 9: Panel cutout - rear mounted receptacles, 300A 14

Figure 10: Panel cutouts - rear mounted receptacles, 500A 14

Figure 11: Panel cutouts - front mounted receptacles, 300A & 500A 15

Figure 12: Backshell with o-ring in position ready for assembly 16

Figure 13: Tightening backshell using strap wrench/torque wrench combination..... 17

Figure 14: Outline and dimensions, 300A plug..... 18

Figure 15: Outline and dimensions, 300A rear mount receptacle..... 18

Figure 16: Outline and dimensions, 300A front mount receptacle..... 19

Figure 17: Outline and dimensions, 300A receptacle with straight backshell 19

Figure 18: Outline and dimensions, 500A plug..... 20

Figure 19: Outline and dimensions, 500A rear mount receptacle..... 20

Figure 20: Outline and dimensions, 500A front mount receptacle..... 21

Figure 21: Outline and dimensions, 500A receptacle with straight backshell 21

Figure 22: Straight backshell dimensions..... 22

Figure 23: Right angle backshell dimensions 22

WORKSHOP MANUAL

This manual details operations and equipment that are necessary to maintain conformity with the product specification and to ensure safe installation.

1 SPECIAL TOOLS AND PROCESSES

1.1 CRIMP TOOLING

Klauke crimp tooling is recommended for terminating cables to connector crimp barrels and terminal lugs.

Battery powered tool (mini electro-hydraulic) = EK354.

Crimp tools and dies listed in the following tables are available from Smiths Connectors.

1.2 CRIMP DIES BY CODE/LUG AND CABLE SIZE – 300A RANGE

Termination code or lug ref	Cable CSA (mm ²)	Crimp barrel ID (mm)	Crimp style	No. of crimps	Die for use with EK354 tool
D	25	7.9	Hex	2	HR425
K	35	9.2	Hex	2	HR435
S	50	11.0	Hex	2	HR450
HBB-950-8-25-A-68	25	7.0	Hex	2	HR425
HBB-950-8-25-B-68	25	7.9	Hex	2	HR425
HBB-950-8-35-A-68	35	8.5	Hex	2	HR435
HBB-950-8-35-B-68	35	9.2	Hex	2	HR435
HBB-950-8-50-A-68	50	10.0	Hex	2	HR450
HBB-950-8-50-B-68	50	11.0	Hex	2	HR450
HBB-950-8-70-A-68	70	12.0	Hex	2	HR470
HBB-950-8-70-B-68	70	13.0	Hex	2	HR470

1.1 CRIMP DIES BY CODE/LUG AND CABLE SIZE – 500A RANGE

Termination code or lug ref	Cable CSA (mm ²)	Crimp barrel ID (mm)	Crimp style	No. of crimps	Die for use with EK354 tool
D	50	11.0	Hex	2	HR450
H	70	13.0	Hex	2	HR470
Q	95	14.5	Hex	2	HR495
V	120	15.0	Hex	2	HR4120
HBB-950-10-50-A-68	50	10.0	Hex	2	HR450
HBB-950-10-50-B-68	50	11.0	Hex	2	HR450
HBB-950-10-70-A-68	70	12.0	Hex	2	HR470
HBB-950-10-70-B-68	70	13.0	Hex	2	HR470
HBB-950-10-95-A-68	95	13.5	Hex	2	HR495
HBB-950-10-95-B-68	95	14.5	Hex	2	HR495
HBB-950-10-120-A-68	120	15.0	Hex	2	HR4120
HBB-950-10-120-B-68	120	16.2	Hex	2	HD4120

1.2 HEAT GUN FOR SHRINKING BOOTS AND SLEEVING

The power and temperature range of the heat gun required for these processes is dictated by the requirements of the manufacturers and suppliers of the heat shrink sleeving or boots.

1.3 STRAP WRENCH

When attaching straight and angled backshells to metal plugs and receptacles, use of a strap wrench is advisable, e.g. Glenair TG70. See torque settings table below.

1.4 TORQUE WRENCH

A metric torque wrench or a range of torque drivers is required for tightening terminal bolts, backshell covers and other fasteners.

1.5 FASTENER SPECIFICATION

For busbar or lug terminations the fasteners required are as follows:

300 amp connectors: M8 x 1.25

500 amp connectors: M10 x 1.5

1.6 TORQUE VALUE TABLE

	Termination screw	Backshell fixing	Backshell cap (captive screw) M3	Panel fixing
300 amp range	M8 thread 8,0Nm \pm 0,5Nm	13Nm \pm 0,6Nm	0,4Nm*	M3 screws 0,4Nm +/-10%
500 amp range	M10 thread 15,0Nm \pm 0,5Nm	15Nm \pm 0,6Nm	0,4Nm*	M4 screws 0,9Nm +/-10%

* use Loctite[®] 221, 222 or equivalent.

2 CABLE PREPARATION

2.1 INSULATION STRIPPING LENGTHS

The combination of contact, lug and backshell options determines the insulation stripping lengths for the main conductors.

2.1.1 CONNECTORS WITH CRIMP BARRELS

These connectors have an inspection hole drilled in the crimp barrel as a guide to the minimum length of insulation to be stripped from the main conductor. Length for a range of typical connectors is indicated by L min in the diagram below. The gap between the open end of the contact crimp barrel and the start of the insulation should be as small as possible.

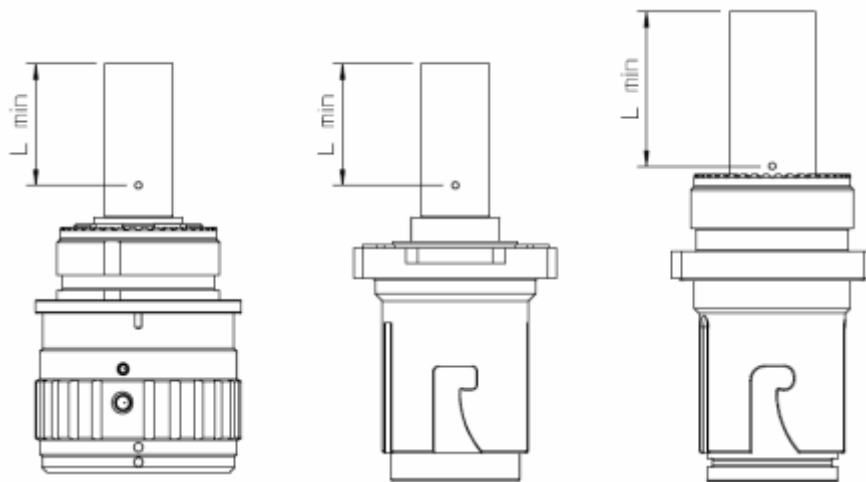

Figure 1: Stripping lengths for connectors with crimp barrels

2.1.2 CONNECTORS WITH BOLTED TERMINALS

These can accept a range of terminals. For connectors with right angle backshells a special Hypertac cable lug must be used. For receptacles and other plugs a standard lug may be suitable, depending on the final application.

If a lug is used, strip the insulation to give the maximum depth of engagement between the main conductor and the lug barrel when crimped. The gap between the open end of the lug barrel and the start of the insulation should be as small as possible.

2.1.3 CONNECTORS WITH RIGHT ANGLE OR STRAIGHT BACKSHELLS

Cables fitted to these connectors must be stripped to take account of the heat shrink boot. Boots must be used on these types of connector to fully seal the cable/backshell joint.

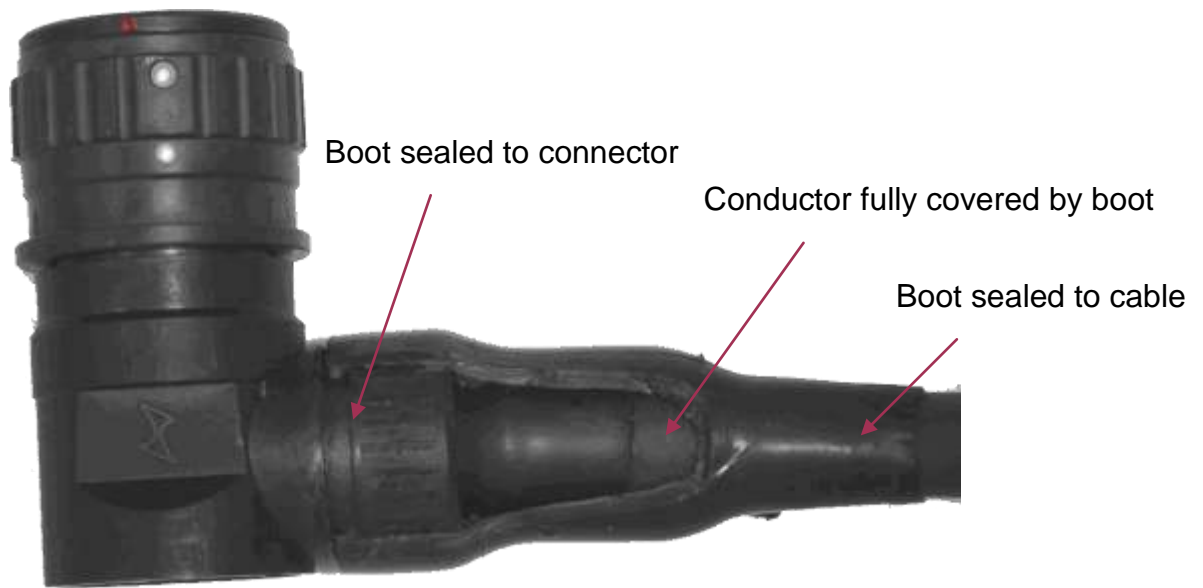

Figure 2: Finished right angle connector sectioned to show fully sealed cable

2.2 OUTER JACKET OF SCREENED CABLES, STRIPPING LENGTHS

For screened cables, outer jackets must be stripped to account for

- i) the length of the backshell,
- ii) the amount of screen braid that needs to be exposed to cover the cable port in the backshell and
- iii) the finished size of the heat shrink boot that finally seals the cable/backshell joint.

3 CRIMPING STANDARD

3.1 TOOLING

Using the recommended tooling and dies, (see Section 1 above) a mechanically and electrically reliable joint can be made between the crimp barrels of contacts or lugs and cables.

3.2 PREPARATION – CONNECTOR ALIGNMENT

Before applying the crimps, mate the connector pair and carry out a trial installation to check that the plug and receptacle will fall into their required orientation when the cable and connector assembly is in its finished state. Use the red alignment dots as a guide to the final positions.

3.3 PREPARATION – ACCESSORY POSITIONING

Before crimping contacts or lugs, position any accessories such as heat shrink tubing, boots, backshells, receptacle o-rings, etc along the cable.

3.4 CRIMPING SEQUENCE AND FINISHED DIMENSIONS – CONTACT BARRELS

The contact barrels are designed to accommodate two crimps, spaced as shown in the diagram below. The 14mm gap between the back of the connector and the first of the two crimps is the smallest that can be achieved with the recommended tooling. The diagram shows finished crimp dimensions for a plug; dimensions for receptacles are similar.

The recommended sequence for applying the crimps is to apply the first at 14mm from the tool “stop” position as indicated in the diagram, followed by the second spaced to give a 15mm span to the whole crimped joint.

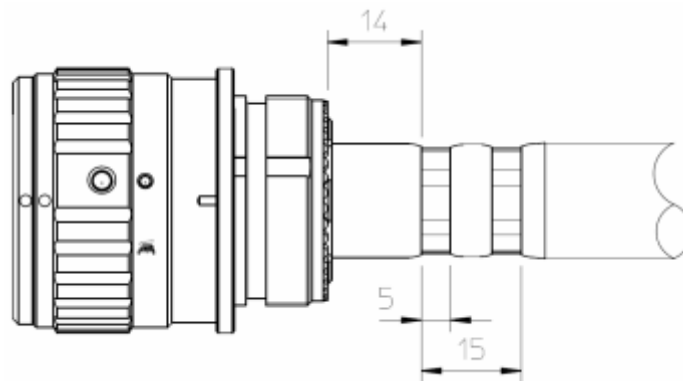
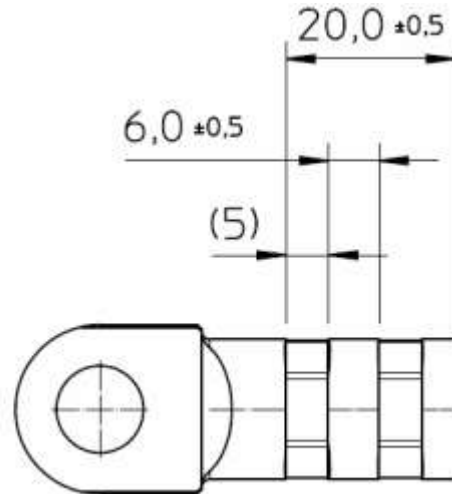

Figure 3: Crimp spacing and typical finished dimensions, contact barrels

3.5 CRIMPING SEQUENCE AND FINISHED DIMENSIONS – CABLE LUGS

Lug barrels are designed to accommodate two crimps, spaced as shown in the diagrams below. Note that the dimensions are different depending on whether the lug is a type “A” or type “B” lug.

CRIMP JOINT DIMENSIONS FOR
HBB-950 SERIES CABLE LUGS,
PART NUMBER SUFFIX -A-68



CRIMP JOINT DIMENSIONS FOR
HBB-950 SERIES CABLE LUGS,
PART NUMBER SUFFIX -B-68

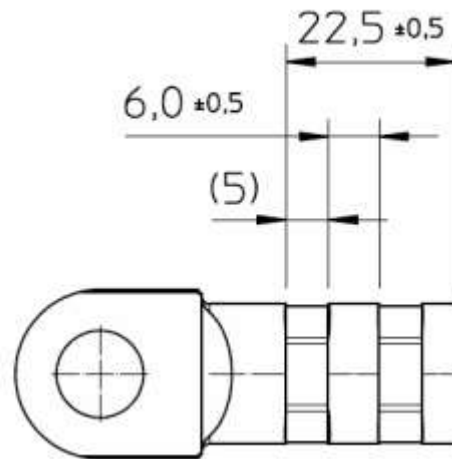

Figure 4: Crimping dimensions for HBB-950 series lugs

3.6 DEBURRING AND FURTHER PREPARATION

Once the crimps have been formed, any burrs that have been raised around the hexagon must be broken or filed off to leave a smooth surface. The barrel surface should then be cleaned with isopropyl alcohol (IPA), ready to accept heat shrink sleeving.

4 CLEANING CABLE INSULATION

To ensure adhesion between cable jackets and sleeving/boots, outer insulation must be cleaned. Follow the heat shrink component manufacturer's instructions for cleaning and surface preparation.

5 APPLYING HEAT SHRINK SLEEVING

5.1 APPLYING SLEEVING TO LUGS

Once the lug and cable jacket have been cleaned and prepared, follow the sleeve manufacturer's instructions and use a heat gun to shrink the adhesive-lined tubing over the lug barrel.

Sleeving must extend up to the flat palm of the lug and must also cover any gap between the lug barrel and the cable insulation.

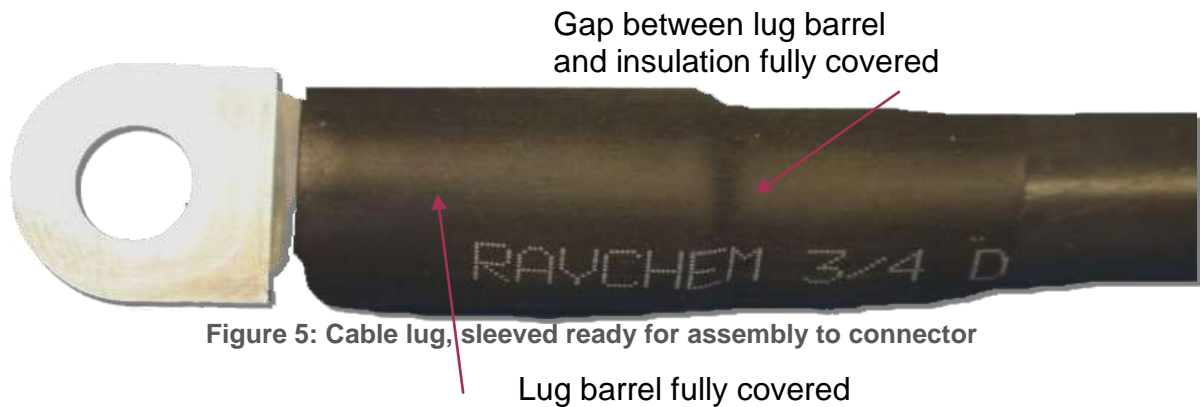

Figure 5: Cable lug, sleeved ready for assembly to connector

5.2 APPLYING SLEEVING TO CONTACT BARRELS

Adhesive-lined sleeving must extend up to the plug or receptacle insulator. It must also seal and cover any gap between the contact barrel and the cable insulation.

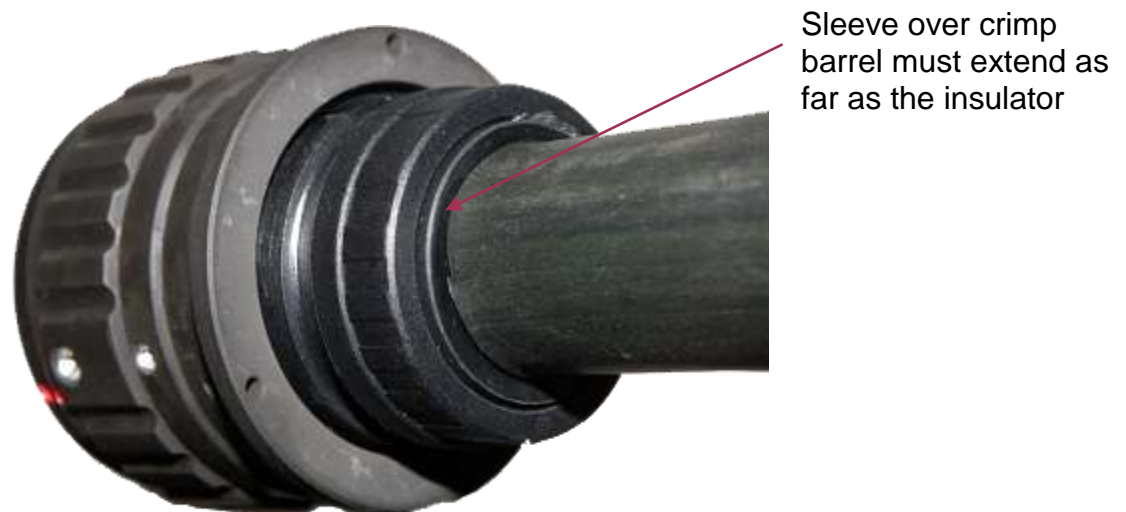

Figure 6: Sleeving of crimp contacts

6 SCREEN BRAIDS, TERMINATING

On the HBB range of connectors, screens can be terminated to the optional straight or right angle backshells. There are no other screen termination options.

Screen braids must be kept away from exposed conductors or fasteners inside the backshell. They must therefore be trimmed so that they will be entirely contained within the heat shrink boot once the boot is applied to the backshell/cable joint.

7 FITTING BOOTS

Ensure that the cable jacket, backshell and surrounding surfaces are clean before applying heat shrink boots. The recommended types of boot are internally lipped; the lip of the boot must engage with corresponding groove or other features on different connectors as shown below.

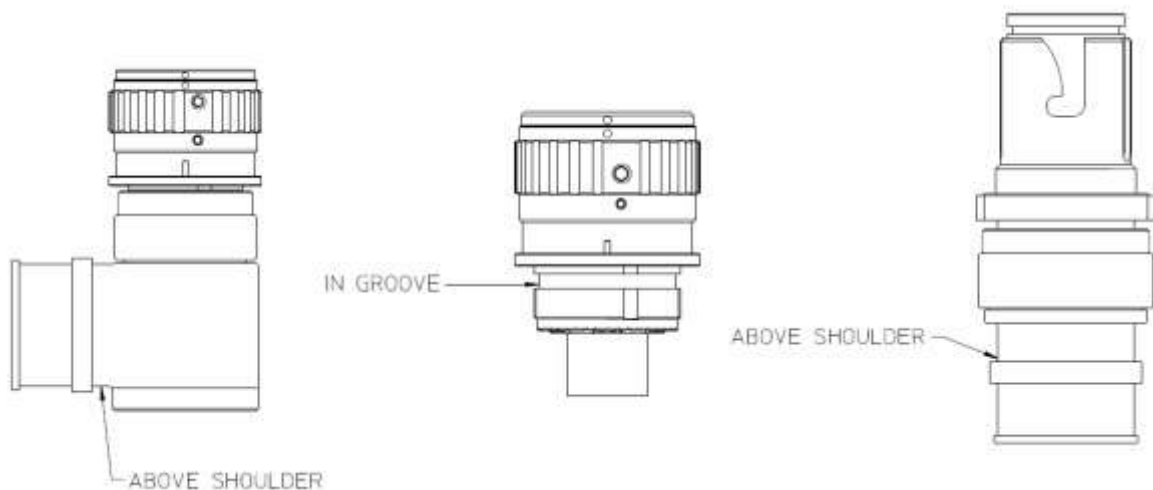

Figure 7: Position of heat shrink boot lips

8 FITTING BACKSHELL CAPS

8.1 RIGHT ANGLE BACKSHELL-EQUIPPED CONNECTORS

Ensure that the o-ring is in position in its groove and that the captive screws are threaded into the cap as shown below. Apply a small quantity of thread locking compound e.g. Loctite 222 to the screws. Allow the two slotted captive screws to drop loosely into position in the tapped holes in the backshell itself. Engage the screw threads and progressively tighten the two screws. Use a torque driver to tighten to the value given in the table above.

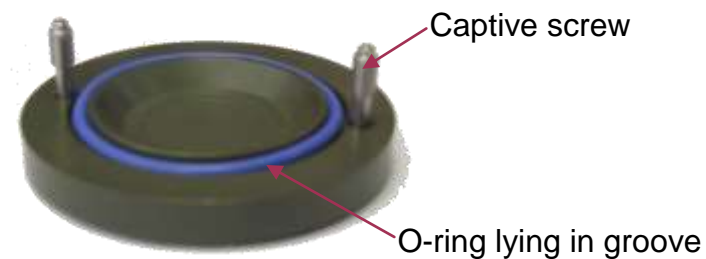

Figure 8: Backshell cap ready for assembly

9 PANEL PREPARATION FOR RECEPTACLES

9.1 STANDARD REAR MOUNT (CONNECTOR MOUNTED BEHIND PANEL/INSIDE BOX)

300 AMP

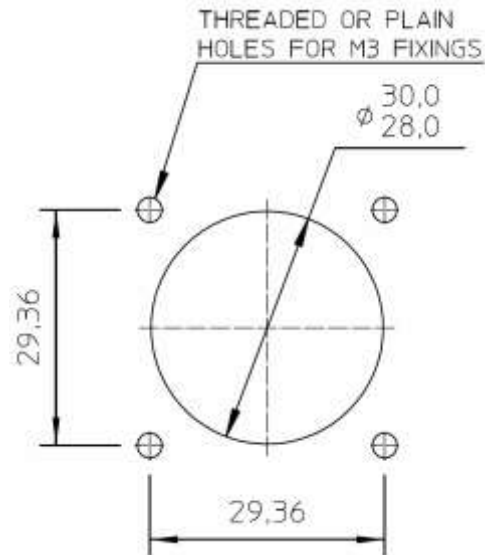

Figure 9: Panel cutout - rear mounted receptacles, 300A

500 AMP

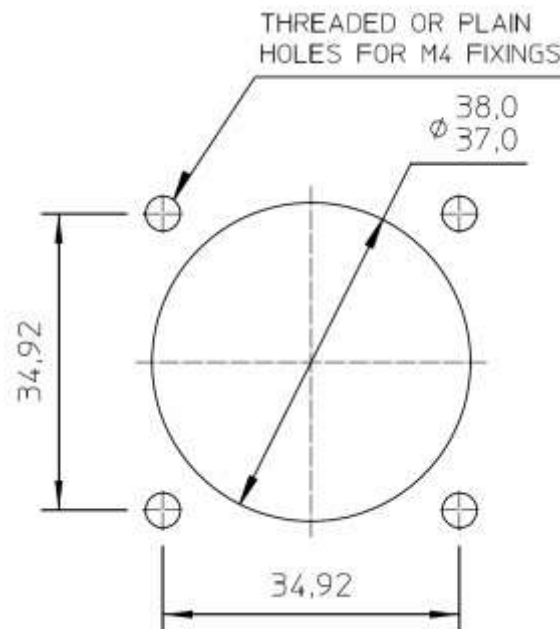

Figure 10: Panel cutouts - rear mounted receptacles, 500A

Recommended maximum panel thickness = 5.0mm.

If panel is more than 3.0mm thick then fixing screws may need to be recessed to give clearance for mating connector.

9.1.1 FRONT MOUNT (CONNECTOR MOUNTED IN FRONT OF PANEL / OUTSIDE BOX)

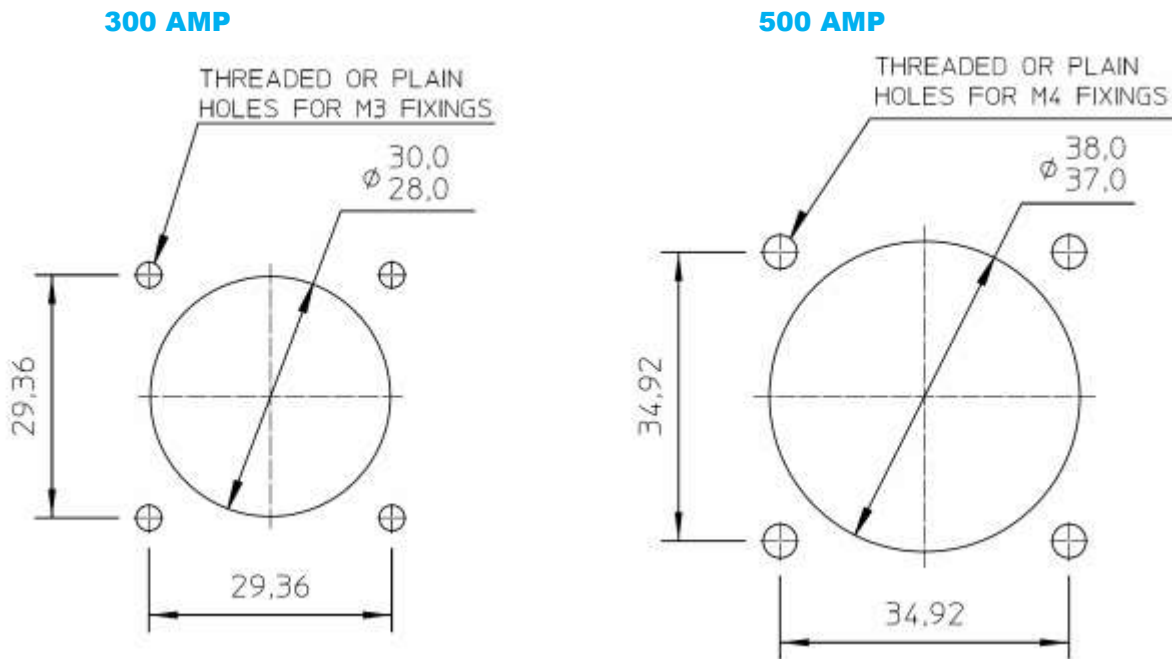

Figure 11: Panel cutouts - front mounted receptacles, 300A & 500A

10 SEALING RECEPTACLES TO PANELS

10.1 STANDARD RECEPTACLES

This style of receptacle is supplied with its panel sealing o-ring. Check that the o-ring is undamaged and place it in its groove in the face of the receptacle flange. Place the receptacle in its correct orientation in the panel cutout. Insert mounting screws and tighten progressively, making certain that the o-ring remains in its groove and does not become damaged e.g. by being crushed between the receptacle flange and the enclosure sealing face.

10.2 FRONT MOUNT RECEPTACLE

This style of receptacle is supplied with an o-ring. Fitting procedure is the same as for standard receptacles.

11 LUG AND BUSBAR FASTENERS

Use a bolt and locking washer to secure lugs or busbar to connector contacts. HBB and HBC range plugs with the right angle backshell option are supplied with fasteners. All other plugs and receptacles are supplied without fasteners. 300 amp fasteners are M8 x 1.25. 500 amp fasteners are M10 x 1.5. When tightening fasteners, take care only to exert an axial torque on the fastener. Do not transmit any load through the fastener to the connector or contact in any other direction.

12 FITTING AND TIGHTENING BACKSHELLS

Where fitted, backshells must be tightened to the maximum values given in the table above. A strap wrench and torque wrench combination or other torque-controlled method can be used. The assembly procedure for both right angle and straight backshells is as follows.

12.1 CHECK O-RING

Check that the sealing o-ring is in position inside the backshell as shown in the illustration.



Figure 12: Backshell with o-ring in position ready for assembly

12.2 ATTACH BACKSHELL

Screw the locking ring over the accessory thread on the back of the connector and screw it loosely home. Check that the relative positions of the cable port and the red alignment marks on the plug body are correct for the final application.

12.3 TIGHTEN BACKSHELL



Figure 13: Tightening backshell using strap wrench/torque wrench combination

Wrap the strap of the wrench around the knurled locking ring (or use other suitable tool). Tighten the backshell to the given torque for the size of shell.

13 CONNECTOR DIMENSIONS AND OUTLINE DRAWINGS

13.1 300 AMP PLUG

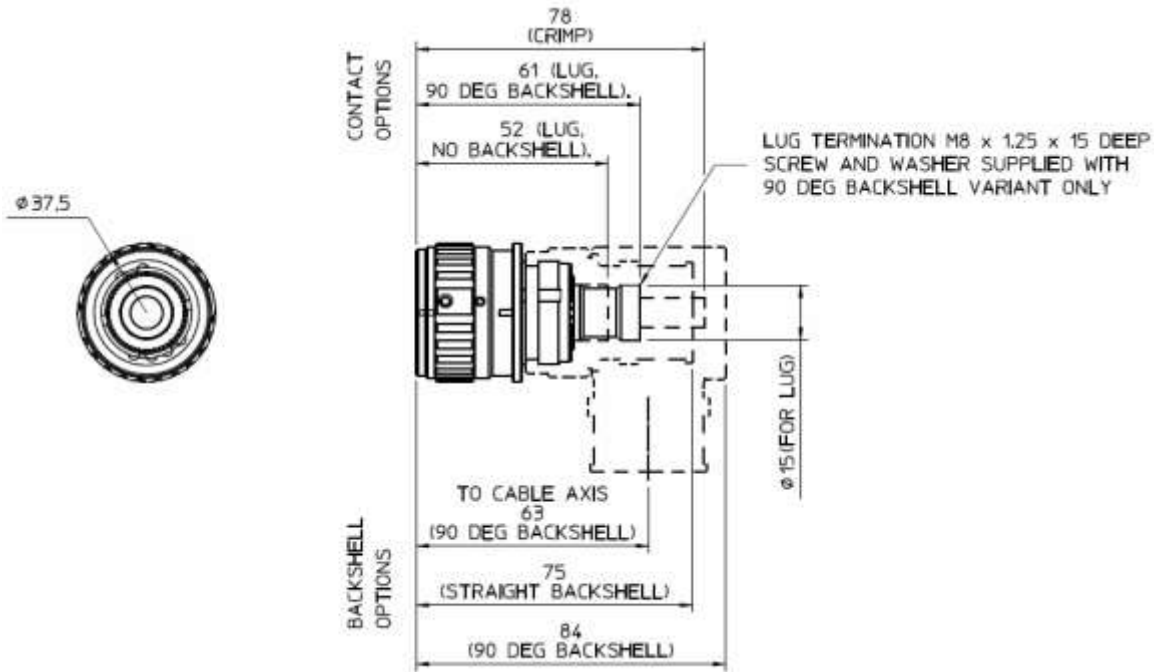

Figure 14: Outline and dimensions, 300A plug

13.2 300 AMP REAR MOUNT RECEPTACLE

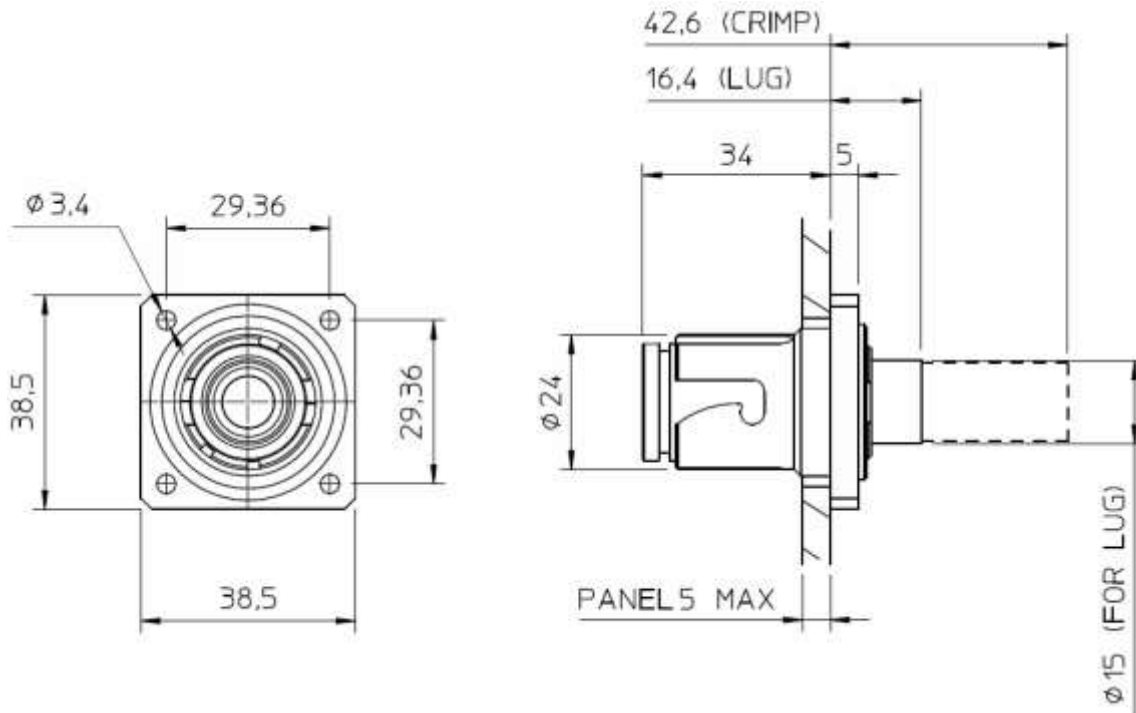

Figure 15: Outline and dimensions, 300A rear mount receptacle

Dimensions in mm.
 Drawings not to scale.
 Transit caps not shown

13.3 300 AMP FRONT MOUNT RECEPTACLE

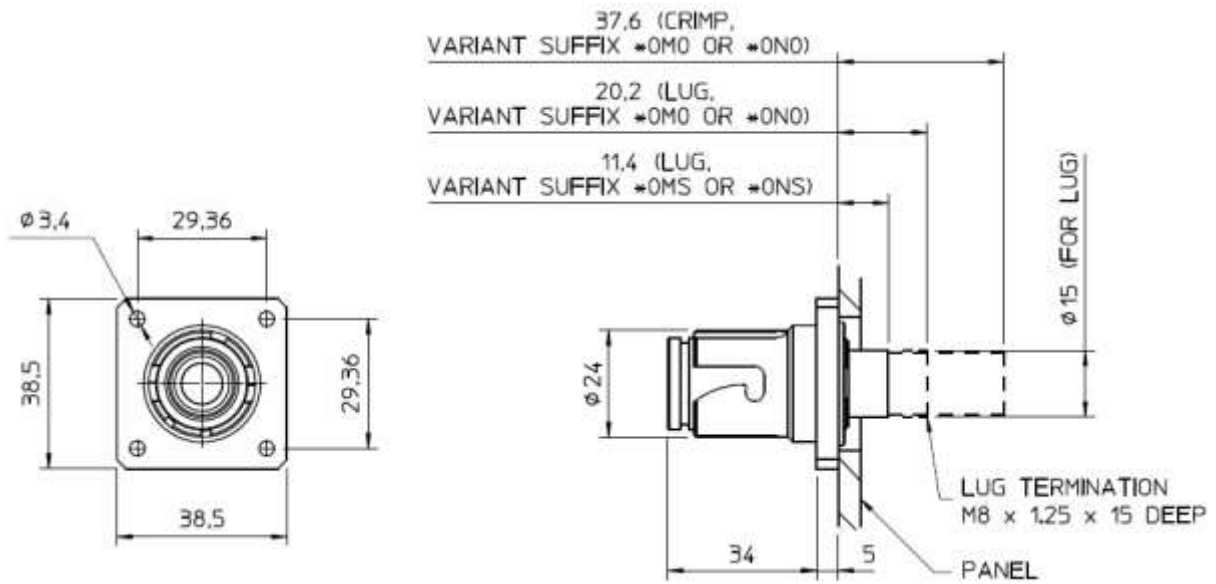

Figure 16: Outline and dimensions, 300A front mount receptacle

13.4 300 AMP RECEPTACLE WITH STRAIGHT BACKSHELL, REAR MOUNT

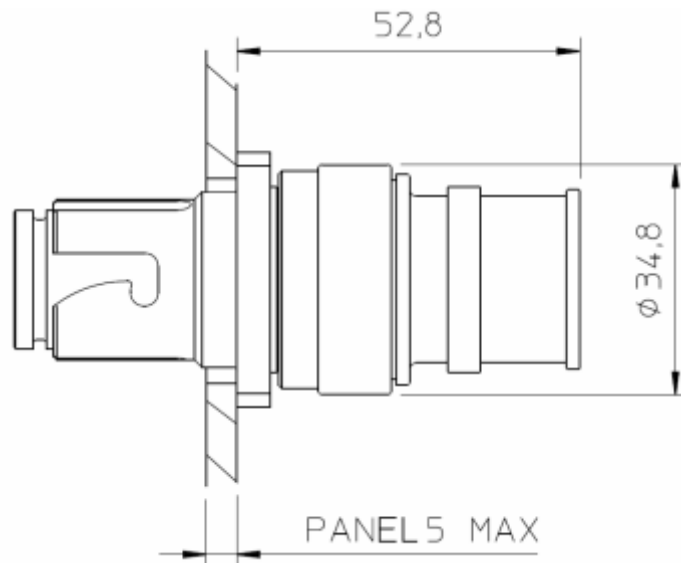

Figure 17: Outline and dimensions, 300A receptacle with straight backshell

Dimensions in mm.
Drawings not to scale.
Transit caps not shown

13.5 500 AMP PLUG

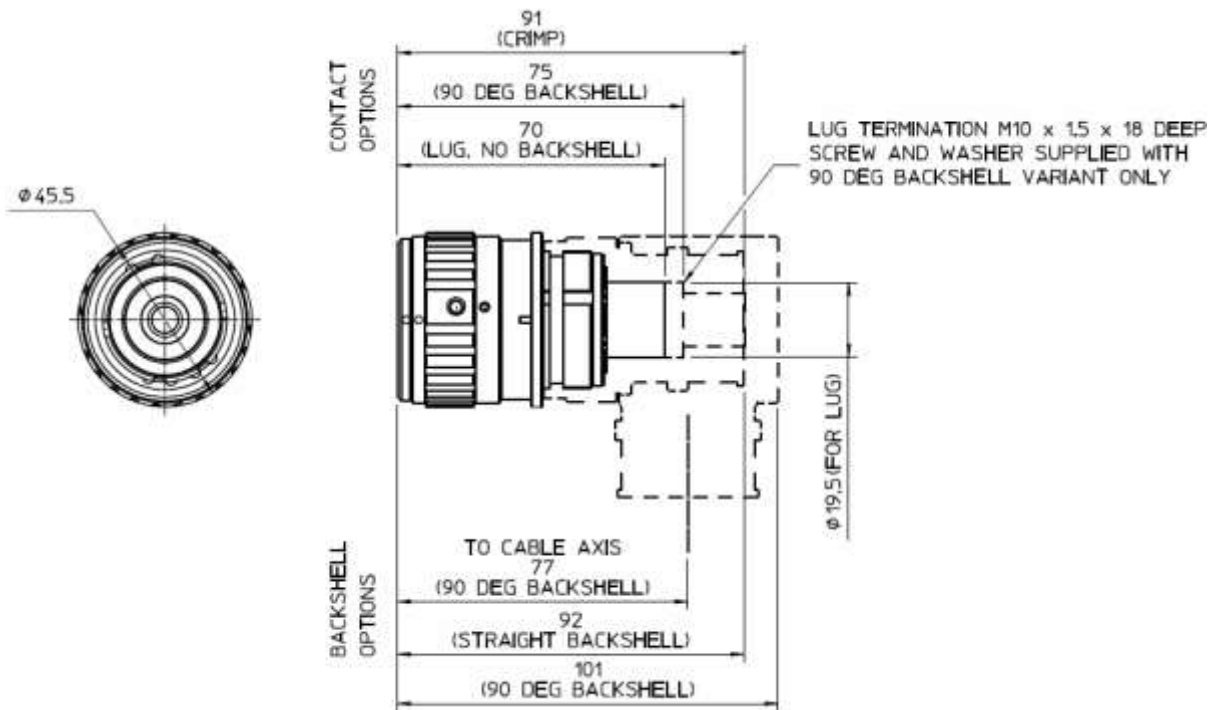

Figure 18: Outline and dimensions, 500A plug

13.6 500 AMP REAR MOUNT RECEPTACLE

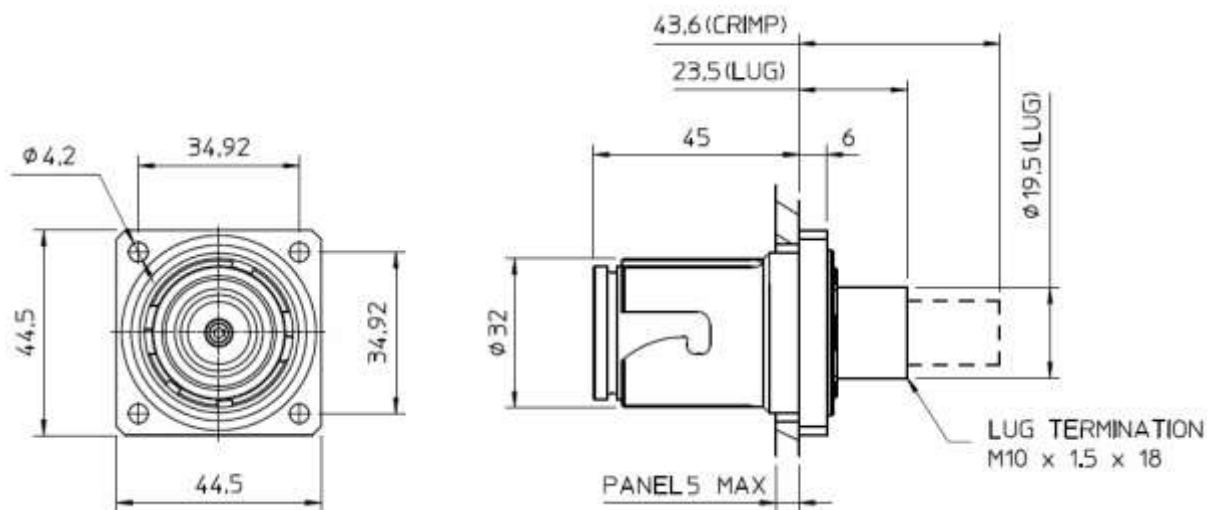

Figure 19: Outline and dimensions, 500A rear mount receptacle

Dimensions in mm
 Drawings not to scale
 Transit caps not shown

13.7 500 AMP FRONT MOUNT RECEPTACLE

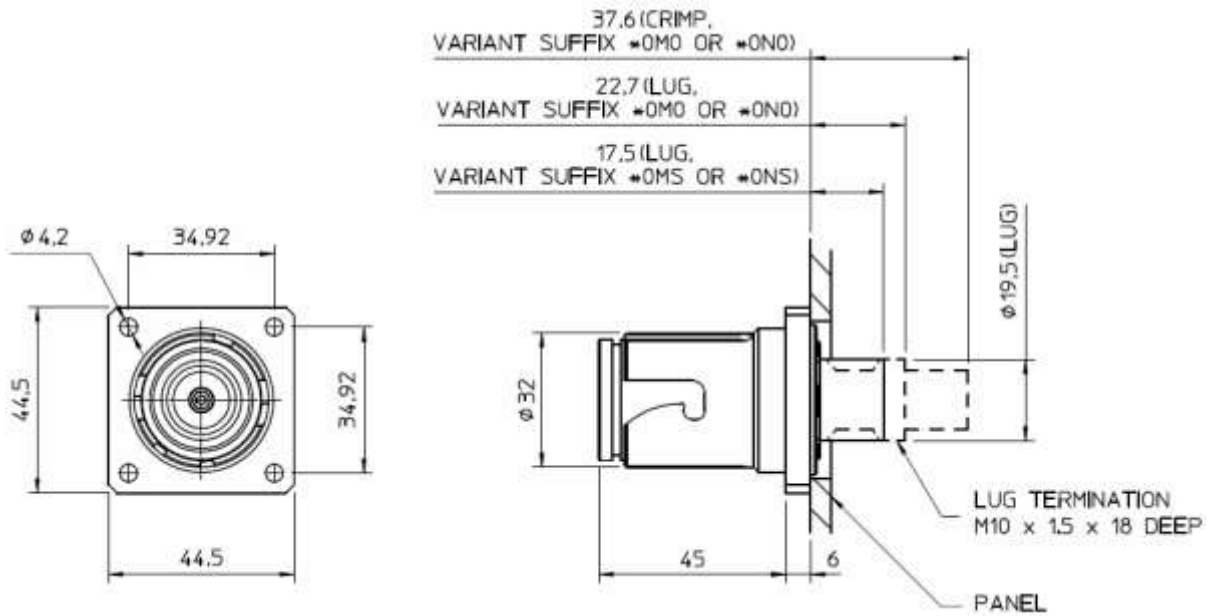

Figure 20: Outline and dimensions, 500A front mount receptacle

13.8 500 AMP RECEPTACLE WITH STRAIGHT BACKSHELL, REAR MOUNT

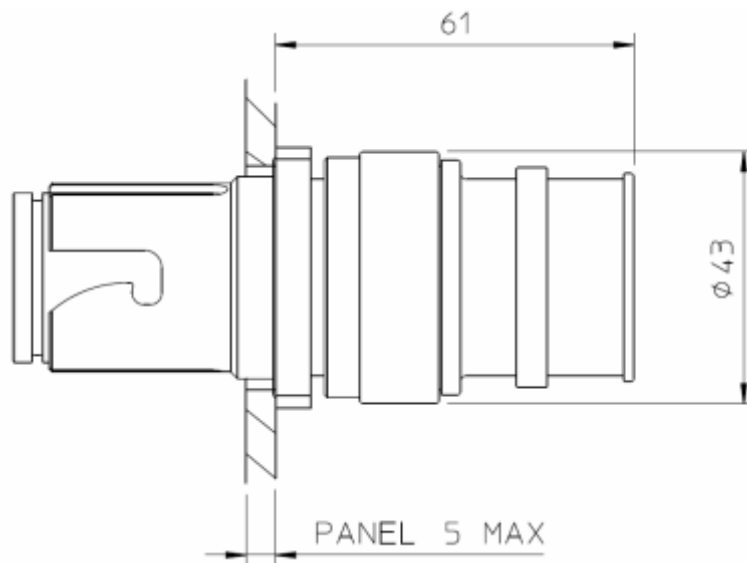

Figure 21: Outline and dimensions, 500A receptacle with straight backshell

Dimensions in mm
 Drawings not to scale
 Transit caps not shown

14 METAL BACKSHELL DIMENSIONS

14.1 STRAIGHT OPTION

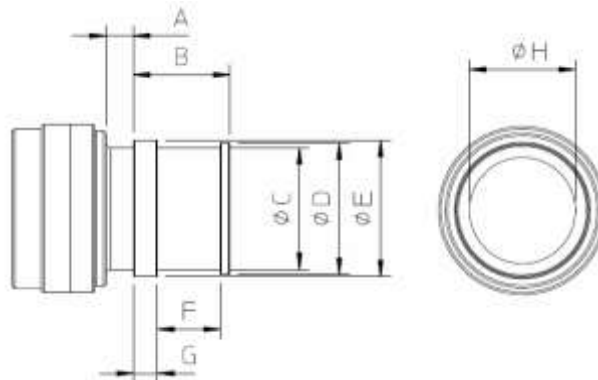

Figure 22: Straight backshell dimensions

14.2 RIGHT ANGLE OPTION

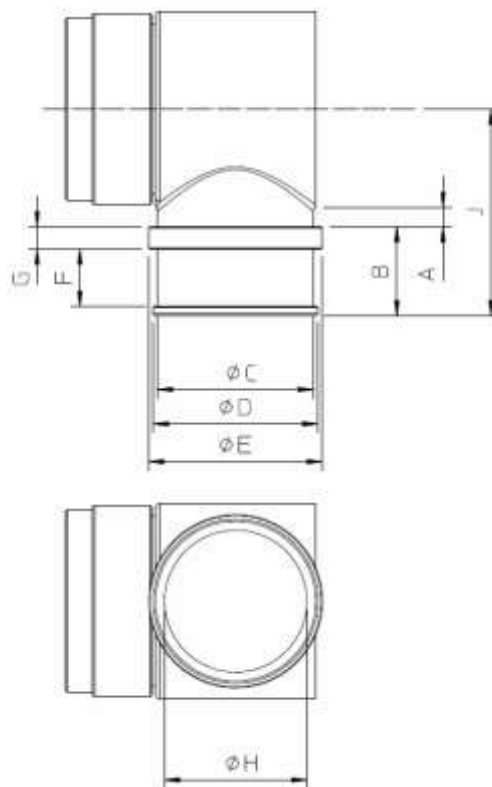

Figure 23: Right angle backshell dimensions

Dimensions in mm	A	B	ØC	ØD	ØE	F	G	ØH	J
300A straight	6	20	25	27	28	13	5	22	n/a
300A right angle	5	20	30	32	33	13	5	27	43
500A straight	9.5	20	34	36	38	13	5	30	n/a
500A right angle	4	20	35	37	39	13	5	32	47

15 INDEX

- backshell
 - right angle; 16; 22
 - straight; 16; 22
- backshell cap; 13
- backshell dimensions; 22
- cable jacket
 - cleaning & preparation; 11; 12
 - stripping; 7; 8
- captive screw; 6; 13
- crimp process
 - for Hypertac special lugs; 9
 - number of crimps, spacing & sequence; 9
- fasteners; 6
 - 300A; 15
 - 500A; 15
 - busbar; 6
 - lug; 6
 - torque settings; 6
- heat shrink; 6; 7; 8; 10; 11; 12
- heat shrink boot; 7; 8
 - positioning; 12
- IPA; 10
- isopropyl alcohol; 10
- Loctite
 - backshell caps; 6; 13
 - lug; 7; 15
 - Hypertac special; 7; 9
 - standard; 7
- metric thread specification; 6; 15
- o-ring
 - backshell; 16
 - backshell cap, metal; 13
 - metal receptacle; 15
- panel preparation
 - receptacles; 14
- screen braid; 8; 12
- screen termination; 12
- seal
 - backshell; 16
 - backshell cap, metal; 13
- strap wrench; 6; 16
- torque driver; 6; 13
- torque settings; 6; 16; 17

SMITHS CONNECTORS

GLOBAL SUPPORT

AMERICAS

Irvine, CA	1.949.250.1244
Kansas City, KS	1.913.342.5544
Hudson, MA	1.978.568.0451

EUROPE

United Kingdom	44.(0)20.8450.8033
Italy	39.010.60361
Germany	49.(0)991.250120
France	33.(0)2.32969176

ASIA

Shanghai, China	86.21.3318.4650
Suzhou, China	86.512.6273.1069
Singapore	65.6846.1655
Bangalore, India	91.80.4241.0500