

HYPER Series

Superior Performing Hypertac® Hyperboloid Contact Technology

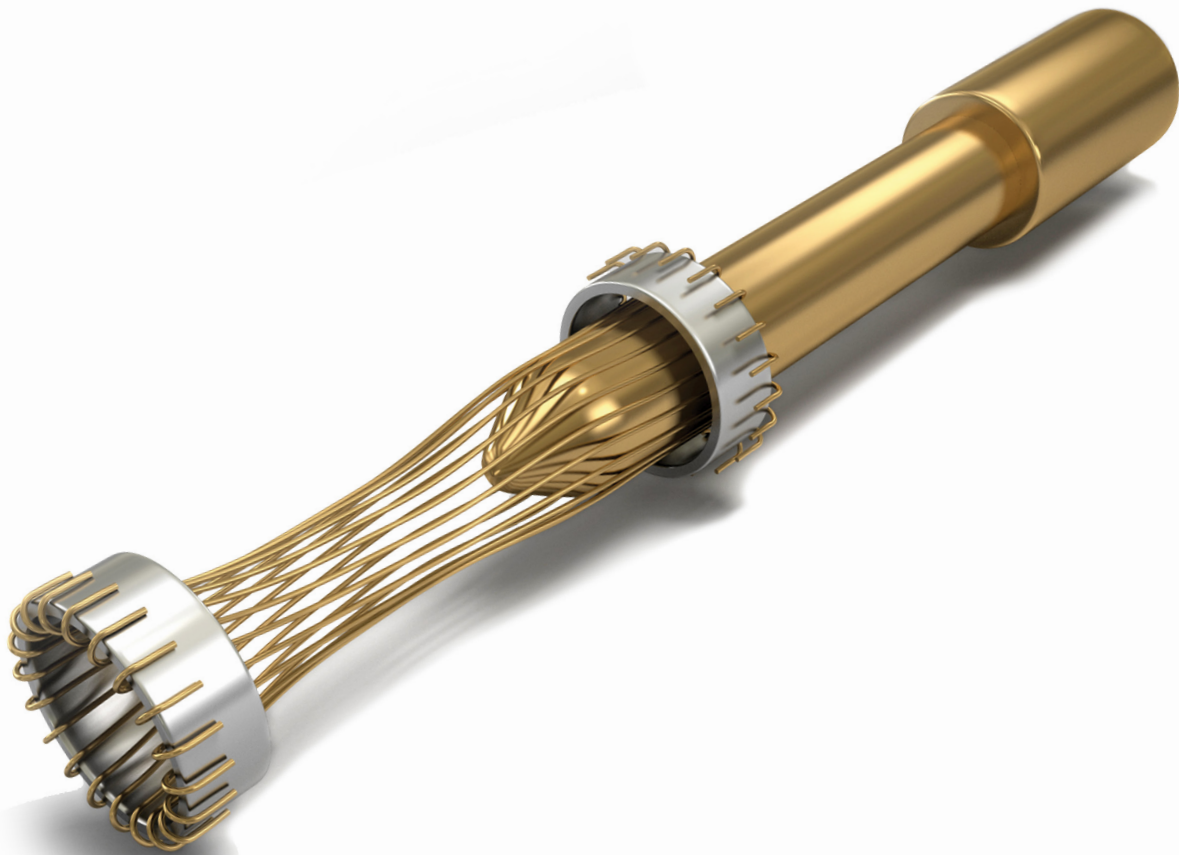

Hypertac® Hyperboloid Contacts



Smiths Interconnect offers an extensive range of superior contact technologies suitable for standard and custom solutions.

HYPER Series offers the original superior performing hyperboloid contact technology designed for use in all applications and in harsh and demanding environments where high reliability and safety are critical.

The inherent electrical and mechanical characteristics of the Hypertac® HYPERboloid conTACT ensures unrivalled performance in terms of reliability, number of mating cycles, low contact force and minimal contact resistance. The shape of the contact sleeve is formed by hyperbolically arranged contact wires, which align themselves elastically as contact lines around the pin, providing a number of linear contact paths.

Features	Benefits
<p>Low insertion/extraction forces</p> <p>The angle of the socket wires allows tight control of the pin insertion and extraction forces. The spring wires are smoothly deflected to make line contact with the pin.</p>	<p>High density interconnect systems</p> <p>Significant reductions in size and weight of sub-system designs. No additional hardware is required to overcome mating and un-mating forces.</p>
<p>Long contact life</p> <p>The smooth and light wiping action minimizes wear on the contact surfaces. Contacts perform up to 100,000 insertion/extraction cycles with minimal degradation in performance.</p>	<p>Low cost of ownership</p> <p>The Hypertac contact technology will surpass most product requirements, thus eliminating the burden and cost of having to replace the connector or the entire subsystem.</p>
<p>Lower contact resistance</p> <p>The design provides a far greater contact area and the wiping action of the wires insures a clean and polished contact surface. Our contact technology has half the resistance of conventional contact designs.</p>	<p>Low power consumption</p> <p>The lower contact resistance of our technology results in a lower voltage drop across the connector reducing the power consumption and heat generation within the system.</p>
<p>Higher current ratings</p> <p>The design parameters of the contact (e.g., the number, diameter and angle of the wires) may be modified for any requirement. The number of wires can be increased so the contact area is distributed over a larger surface. Thus, the high current carried by each wire because of its intimate line contact, can be multiplied many times.</p>	<p>Maximum contact performance</p> <p>The lower contact resistance of the Hypertac contact reduces heat build-up; therefore Hypertac contacts are able to handle far greater current in smaller contact assemblies without the detrimental effects of high temperature.</p>
<p>Immunity to shock & vibration</p> <p>The low mass and resultant low inertia of the wires enable them to follow the most abrupt or extreme excursions of the pin without loss of contact. The contact area extends 360 degrees around the pin and is uniform over its entire length. The 3 dimensional symmetry of the Hypertac contact design guarantees electrical continuity in all circumstances.</p>	<p>Reliability under harsh environments</p> <p>Harsh environmental conditions require connectors that will sustain their electrical integrity even under the most demanding conditions such as shock and vibration. The Hypertac contact provides unmatched stability in demanding environments when failure is not an option.</p>

Contents

Features and Benefits	2
Contacts	4
0.40 mm (0.016 in.) contacts	4
0.50 mm (0.020 in.) contacts	5
0.60 mm (0.024 in.) contacts	6
0.76 mm (0.030 in.) contacts	7
1.00 mm (0.039 in.) contacts	8
1.02 mm (0.040 in.) contacts	9
1.20 mm (0.047 in.) contacts	10
1.50 mm (0.059 in.) contacts	11
1.50 mm (0.059 in.) contacts	12
2.00 mm (0.079 in.) contacts	13
2.50 mm (0.098 in.) contacts	14
3.50 mm (0.120 in.) contacts	15
3.60 mm (0.140 in.) contacts	16
4.30 mm (0.170 in.) contacts	17
6.12 mm (0.240 in.) contacts	18
How to Order	19
Crimp Tools & Positioners	19

0.40 mm (0.016 in.) contacts

Female contacts (sockets)

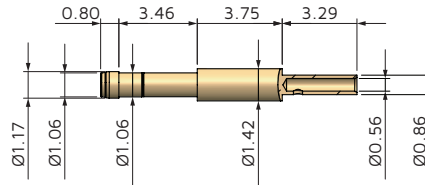

HYPS040C127A001

Ordering Number	Internal Part Number	Termination Style	Contact Resistance (mΩ)	Current Rating (A)	Extraction Force (N)	Contact Life (cycles)	Materials	Plating (μm)
HYPS040C127A001	YSK004-002AH	Crimp	<8.0	1.0	0.44	Up to 100k	BeCu/Brass	>1.27 gold

Male contacts (pins)

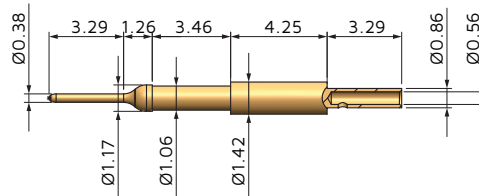

HYPP040C127A001

Ordering Number	Internal Part Number	Termination Style	Materials	Plating (μm)
HYPP040C127A001	YPN004-001H	Crimp	Phosphor bronze	>1.27 gold

0.50 mm (0.020 in.) contacts

Female contacts (sockets)

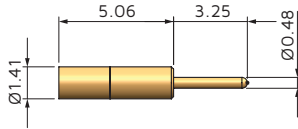

HYPS050S127A001

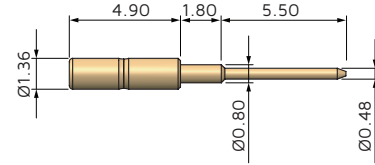

HYPS050S127I001

Ordering Number	Internal Part Number	Termination Style	Contact Resistance (mΩ)	Current Rating (A)	Extraction Force (N)	Contact Life (cycles)	Materials	Plating (µm)
HYPS050S127A001	YSK005-004AH	Straight	<8.0	2.5	0.61	Up to 100k	BeCu/Brass	>1.27 gold
HYPS050S127I001	19000-Z70	Straight	<8.0	2.0	0.10	Up to 100k	BeCu/Brass	>1.27 gold

Male contacts (pins)

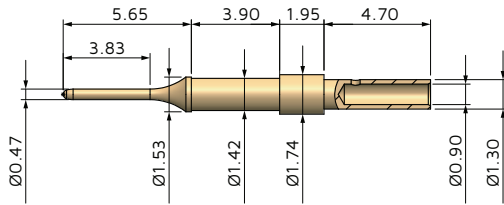

HYPP050C025A001

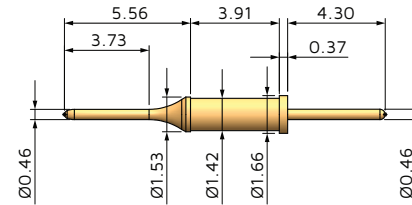

HYPP050S127A001

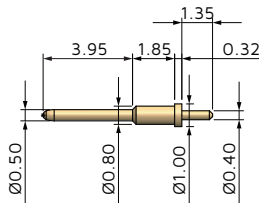

HYPP050S127I001

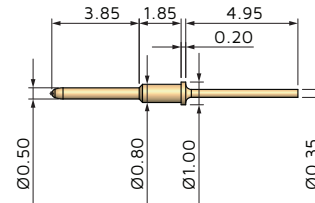

HYPP050S127I002

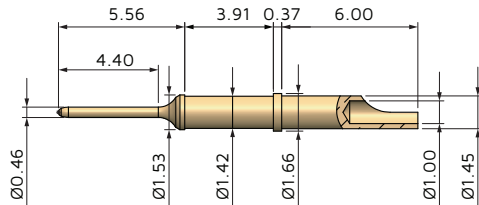

HYPP050U025A001

Ordering Number	Internal Part Number	Termination Style	Materials	Plating (µm)
HYPP050C025A001	YPN005-049G	Crimp	Phosphor bronze	>0.254 gold
HYPP050S127A001	YPN005-004H	Straight	BeCu	>1.27 gold
HYPP050S127I001	18999-T15	Straight	Brass	>1.27 gold
HYPP050S127I002	19068-T15+TT1	Straight	Phosphor bronze	>1.27 gold
HYPP050U025A001	YPN005-090G	Solder cup	Phosphor bronze	>0.254 gold

0.60 mm (0.024 in.) contacts

Female contacts (sockets)

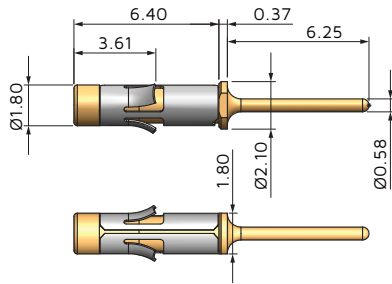

HYP060S127A001

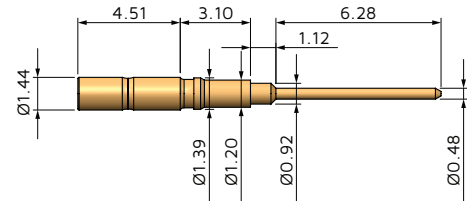

HYP060S127I001

Ordering Number	Internal Part Number	Termination Style	Contact Resistance (mΩ)	Current Rating (A)	Extraction Force (N)	Contact Life (cycles)	Materials	Plating (μm)
HYP060S127A001	YSK006-005AH	Straight	<5.0	4.0	0.08 to 0.56	Up to 100k	BeCu/Brass	>1.27 gold
HYP060S127I001	16477 REF. 4 Z57	Straight	<8.0	2.0	0.1	Up to 100k	BeCu/Brass	>1.27 gold

Male contacts (pins)

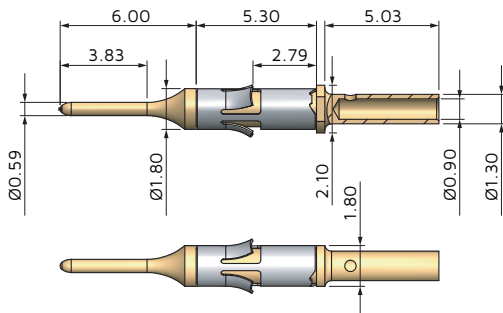

HYPP060C127A001

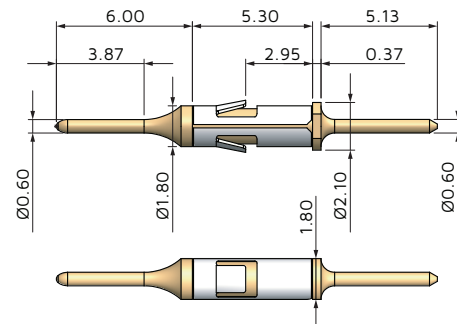

HYPP060S127I002

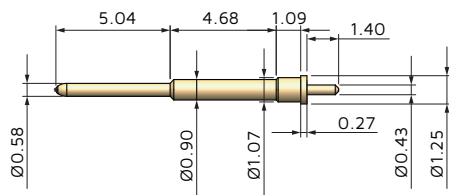

HYPP060S127I001

Ordering Number	Internal Part Number	Termination Style	Materials	Plating (μm)
HYPP060C127A001	YPN006-021H	Crimp	Brass	>1.27 gold
HYPP060S127I002	13280 REF. 1 T15	Straight	Brass	>1.27 gold
HYPP060S127I001	16390-T15	Straight	Brass	>1.27 gold

0.76 mm (0.030 in.) contacts

Female contacts (sockets)

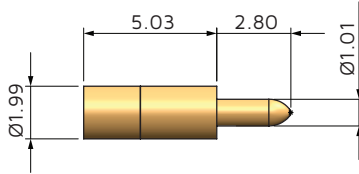

HYP5076S127A001

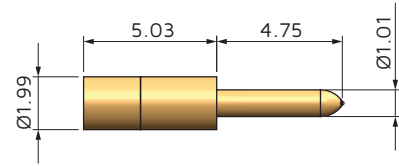

HYP5076S127A002

Ordering Number	Internal Part Number	Termination Style	Contact Resistance (mΩ)	Current Rating (A)	Extraction Force (N)	Contact Life (cycles)	Materials	Plating (µm)
HYP5076S127A001	YSK0076-011AH	Straight	<5.0	5	0.89	Up to 100k	BeCu/Brass	>1.27 gold
HYP5076S127A002	YSK0076-012AH	Straight	<5.0	5	0.89	Up to 100k	BeCu/Brass	>1.27 gold

Male contacts (pins)

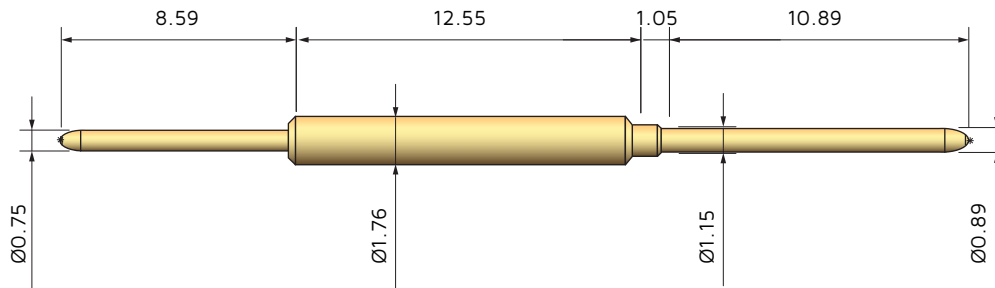

HYP5076S127A001

Ordering Number	Internal Part Number	Termination Style	Materials	Plating (µm)
HYP5076S127A001	YPN0076-101H	Straight	Brass	>1.27 gold

1.00 mm (0.039 in.) contacts

Female contacts (sockets)

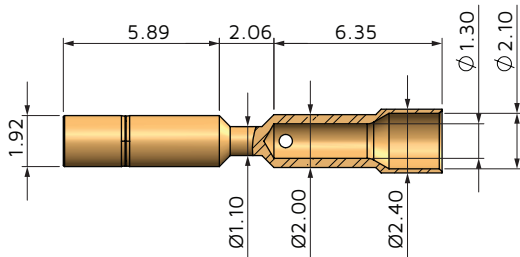

HYPS100C025I001

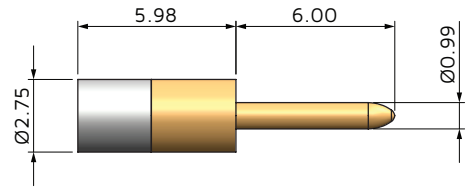

HYPS100S020F001

Ordering Number	Internal Part Number	Termination Style	Contact Resistance (mΩ)	Current Rating (A)	Extraction Force (N)	Contact Life (cycles)	Materials	Plating (μm)
HYPS100C025I001	18369-Z78	Crimp	<2.5	7.5	0.4	Up to 100k	BeCu/Brass	>0.25 gold
HYPS100S020F001	0100232-98-N1	Straight	<5.0	5.0	0.25 to 1.0	Up to 100k	PhBz/Brass	>0.20 gold

Male contacts (pins)

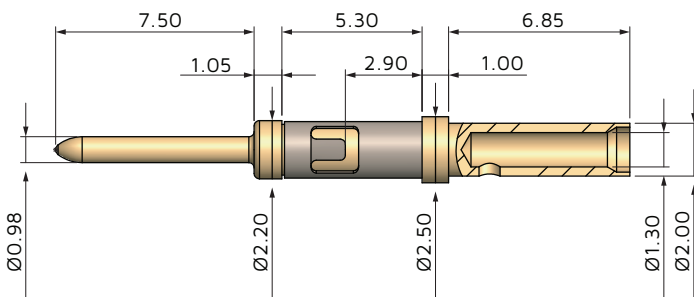

HYPP100C010I001

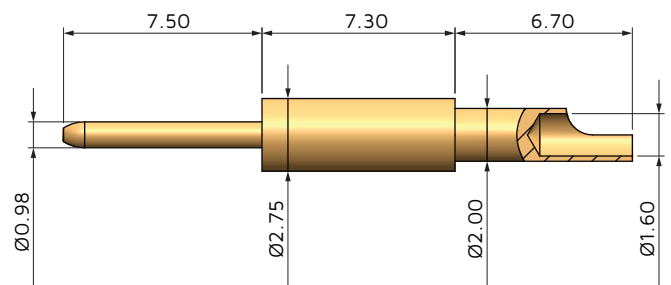

HYPP100U010I001

Ordering Number	Internal Part Number	Termination Style	Materials	Plating (μm)
HYPP100C010I001	17666-T11+TT1	Crimp	Brass	>0.10 gold
HYPP100U010I001	13032-T11	Solder cup	Brass	>0.10 gold

1.02 mm (0.040 in.) contacts

Female contacts (sockets)

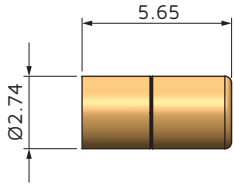

HYP102E127A001

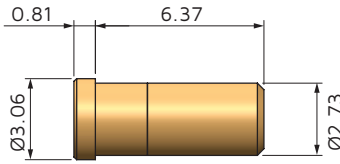

HYP102E127A002

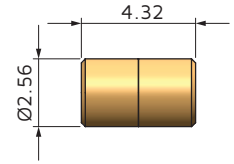

HYP102O127A001

Ordering Number	Internal Part Number	Termination Style	Contact Resistance (mΩ)	Current Rating (A)	Extraction Force (N)	Contact Life (cycles)	Materials	Plating (μm)
HYP102E127A001	YSK0102-060AH	Closed end	<2.5	7.5	1.0	Up to 100k	BeCu/Brass	>1.27 gold
HYP102E127A002	YSK0102-004AH	Closed end	<2.5	7.5	1.0	Up to 100k	BeCu/Brass	>1.27 gold
HYP102O127A001	YSK0102-120AH	Open both ends	<2.5	7.5	1.0	Up to 100k	BeCu/Brass	>1.27 gold

Male contacts (pins)

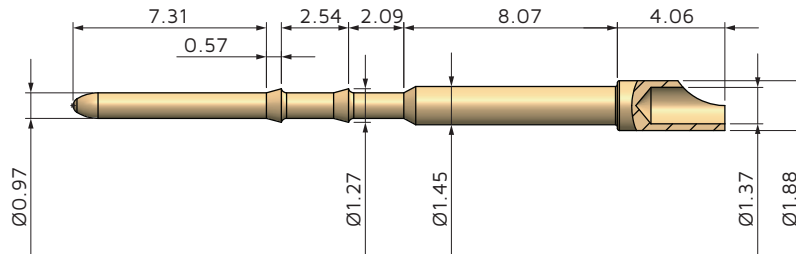

HYP102U127A001

Ordering Number	Internal Part Number	Termination Style	Materials	Plating (μm)
HYP102U127A001	YPN0102-052H	Solder cup	Brass	>1.27 gold

1.20 mm (0.047 in.) contacts

Female contacts (sockets)

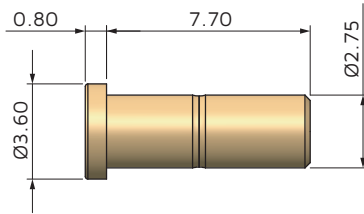

HYPS120E025I001

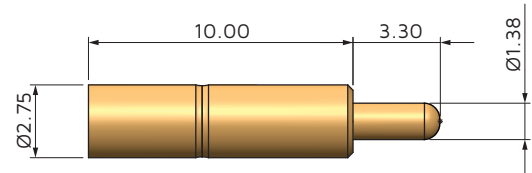

HYPS120S025I001

Ordering Number	Internal Part Number	Termination Style	Contact Resistance (m Ω)	Current Rating (A)	Extraction Force (N)	Contact Life (cycles)	Materials	Plating (μ m)
HYPS120E025I001	23401-Z65	Closed end	<2.5	9.0	0.6	Up to 100k	BeCu/Brass	>0.25 gold
HYPS120S025I001	23349-Z52	Straight	<2.5	9.0	0.6	Up to 100k	BeCu/Brass	>0.25 gold

Male contacts (pins)

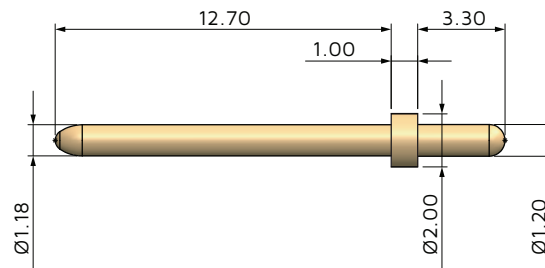

HYPP120S127I001

Ordering Number	Internal Part Number	Termination Style	Materials	Plating (μ m)
HYPP120S127I001	23876-T15	Straight	Brass	>1.27 gold

1.50 mm (0.059 in.) contacts

Female contacts (sockets)

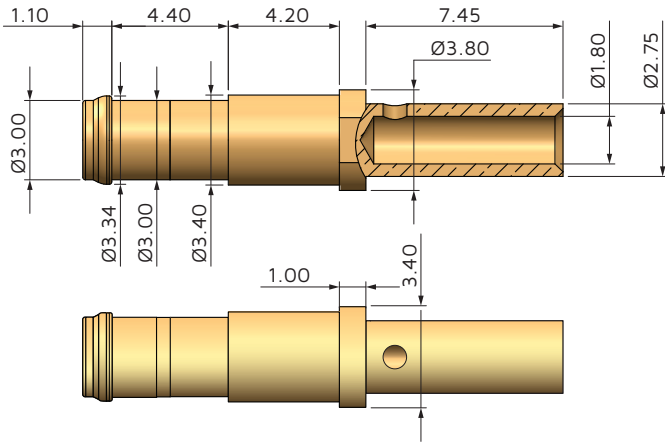

HYPS150C020F001

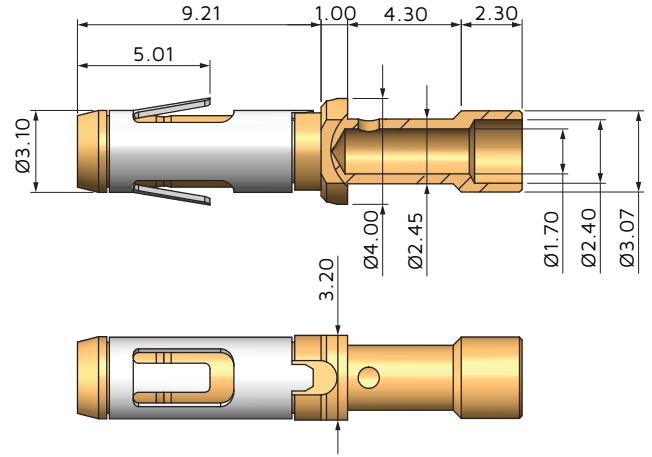

HYPS150C025I001

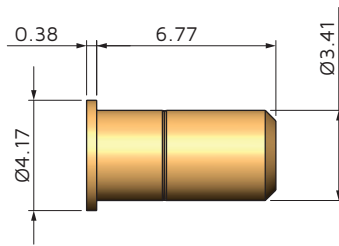

HYPS150E127A001

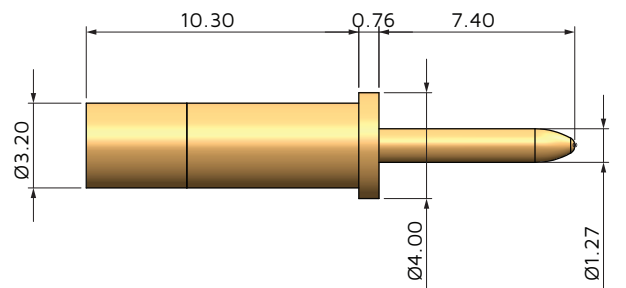

HYPS150S127A001

Ordering Number	Internal Part Number	Termination Style	Contact Resistance (mΩ)	Current Rating (A)	Extraction Force (N)	Contact Life (cycles)	Materials	Plating (µm)
HYPS150C020F001	0150682-20-G1	Crimp	<3.0	8	0.4 to 1.4	Up to 100k	PhBz/Brass	>0.20 gold
HYPS150C025I001	15837-Z66	Crimp	<2.5	8	0.8	Up to 100k	BeCu/Brass	> 1.27 gold
HYPS150E127A001	YSK015-111HT	Closed end	<2.5	10	5.5	Up to 100k	BeCu/Brass	>1.27 gold
HYPS150S127A001	YSK015-004AH	Straight	<2.5	10	5.5	Up to 100k	BeCu/Brass	>1.27 gold

1.50 mm (0.059 in.) contacts

Male contacts (pins)

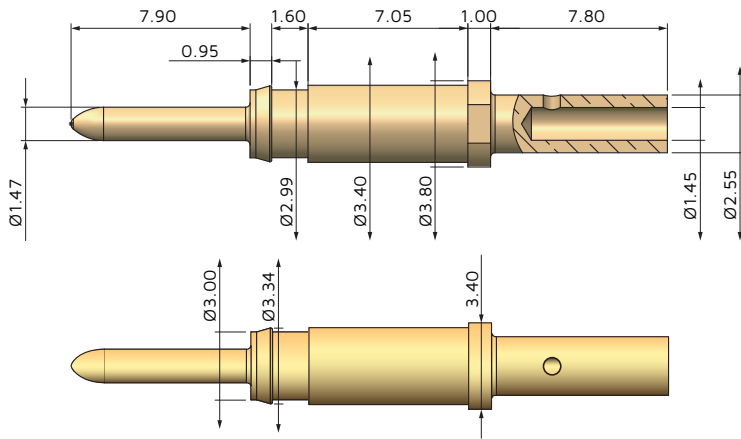

HYPP150C127A001

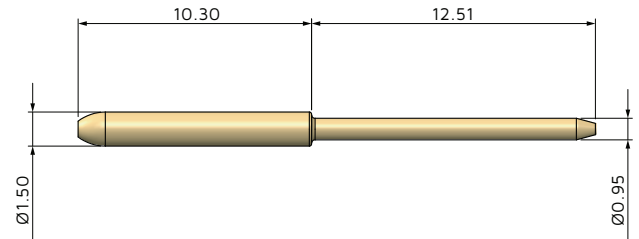

HYPP150S025I001

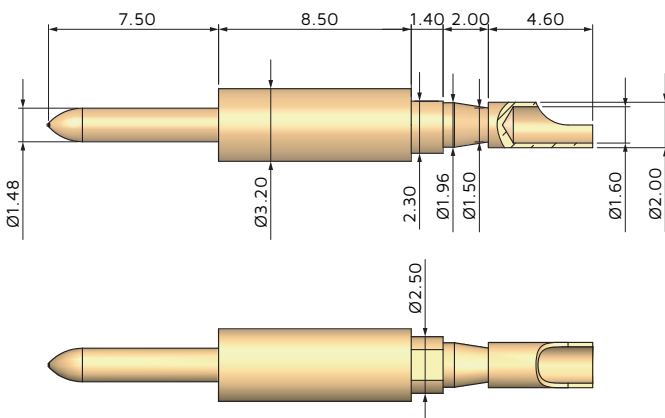

HYPP150U127A001

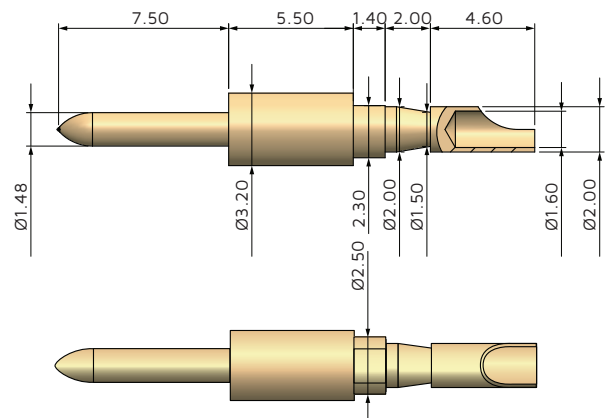

HYPP150U127I001

Ordering Number	Internal Part Number	Termination Style	Materials	Plating (μm)
HYPP150C127A001	YPN015-009RG	Crimp	Brass	>1.27 gold
HYPP150S025I001	16121-T12	Straight	Brass	>0.25 gold
HYPP150U127A001	YPN015-001H	Solder cup	Brass	>1.27 gold
HYPP150U127I001	13380-T12	Solder cup	Brass	>1.27 gold

2.00 mm (0.079 in.) contacts

Female contacts (sockets)

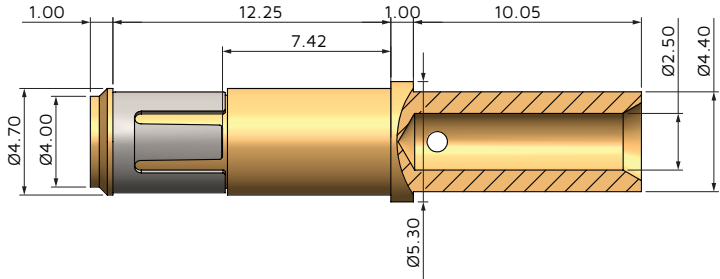

HYP200C020F001

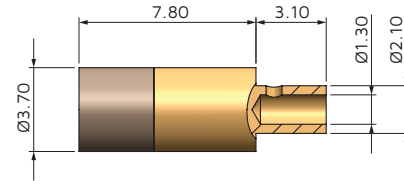

HYP200C025I001

Ordering Number	Internal Part Number	Termination Style	Contact Resistance (mΩ)	Current Rating (A)	Extraction Force (N)	Contact Life (cycles)	Materials	Plating (µm)
HYP200C020F001	0200422-20RN1	Crimp	<2.0	15	1.2 to 4.0	Up to 100k	PhBz/Brass	>0.20 gold
HYP200C025I001	23420-Z72	Solder Cup	<2.0	15	1.2 to 4.0	Up to 100k	PhBz/Brass	>0.25 gold

Male contacts (pins)

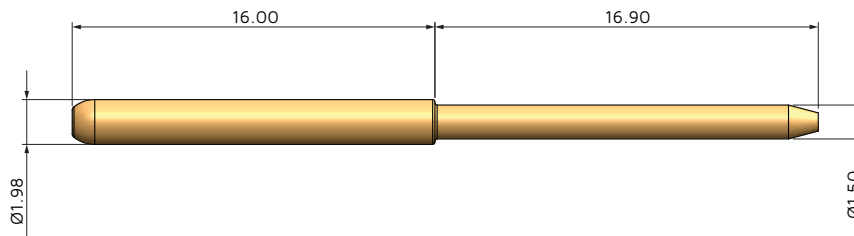

HYP200S025I001

Ordering Number	Internal Part Number	Termination Style	Materials	Plating (µm)
HYP200S025I001	21602-T12	Straight	Copper	>0.25 gold

2.50 mm (0.098 in.) contacts

Female contacts (sockets)

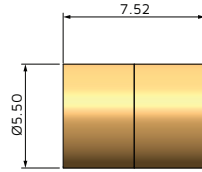

HYPS2500127A001

Ordering Number	Internal Part Number	Termination Style	Contact Resistance (mΩ)	Current Rating (A)	Extraction Force (N)	Contact Life (cycles)	Materials	Plating (μm)
HYPS2500127A001	YSK025-030AH	Open both ends	<1.5	15	7.8	Up to 100k	BeCu/Brass	>1.27 gold

Male contacts (pins)

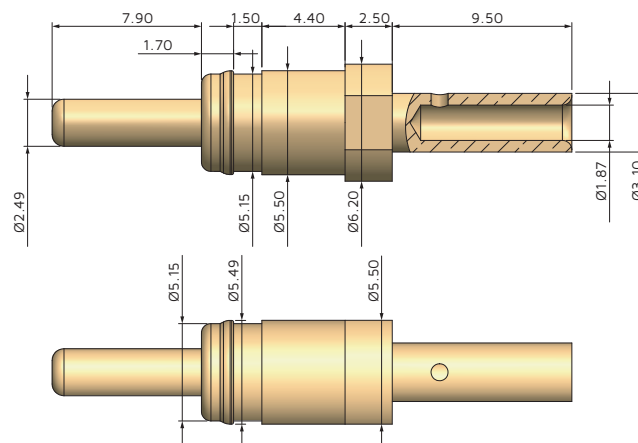

HYPP250C127A001

Ordering Number	Internal Part Number	Termination Style	Materials	Plating (μm)
HYPP250C127A001	YPN025-003H	Crimp	Brass	>1.27 gold

3.50 mm (0.120 in.) contacts

Female contacts (sockets)

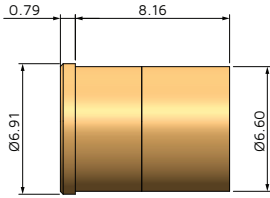

HYPS350E127A001

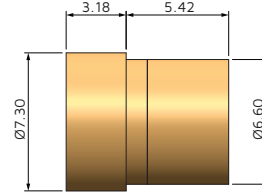

HYP350O127A001

Ordering Number	Internal Part Number	Termination Style	Contact Resistance (mΩ)	Current Rating (A)	Extraction Force (N)	Contact Life (cycles)	Materials	Plating (µm)
HYPS350E127A001	YSK035-063AH	Closed end	<0.8	50	9.7	Up to 100k	BeCu/Brass	>1.27 gold
HYP350O127A001	YSK035-004AH	Open both ends	<0.8	50	9.7	Up to 100k	BeCu/Brass	>1.27 gold

Male contacts (pins)

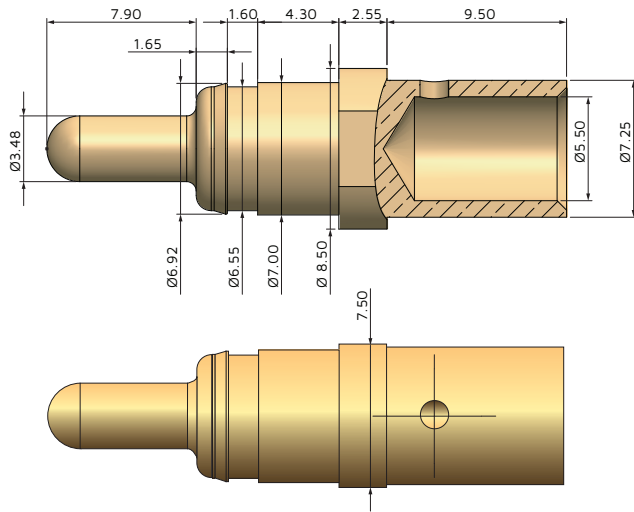

HYPP350C127A001

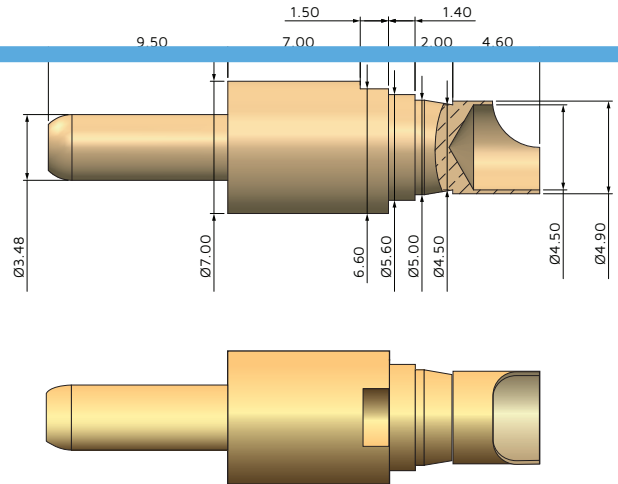

HYP350U127A001

Ordering Number	Internal Part Number	Termination Style	Materials	Plating (µm)
HYPP350C127A001	YPN035-025RH	Crimp	Brass	>1.27 gold
HYP350U127A001	YPN035-024H	Solder cup	Copper	>1.27 gold

3.60 mm (0.140 in.) contacts

Female contacts (sockets)

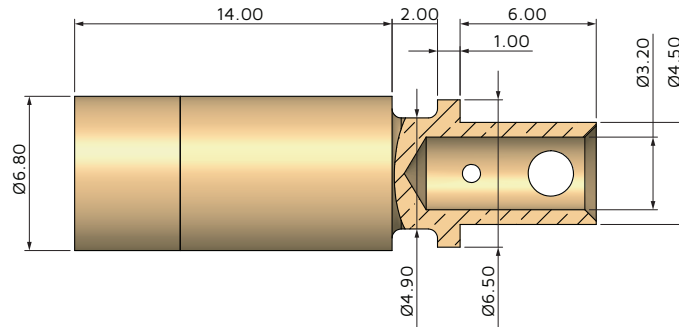

HYPS360C127A001

Ordering Number	Internal Part Number	Termination Style	Contact Resistance (mΩ)	Current Rating (A)	Extraction Force (N)	Contact Life (cycles)	Materials	Plating (μm)
HYPS360C127A001	YSK036-005AH	Solder Cup	<0.5	50	3	Up to 100k	BeCu/Brass	>1.27 gold

Male contacts (pins)

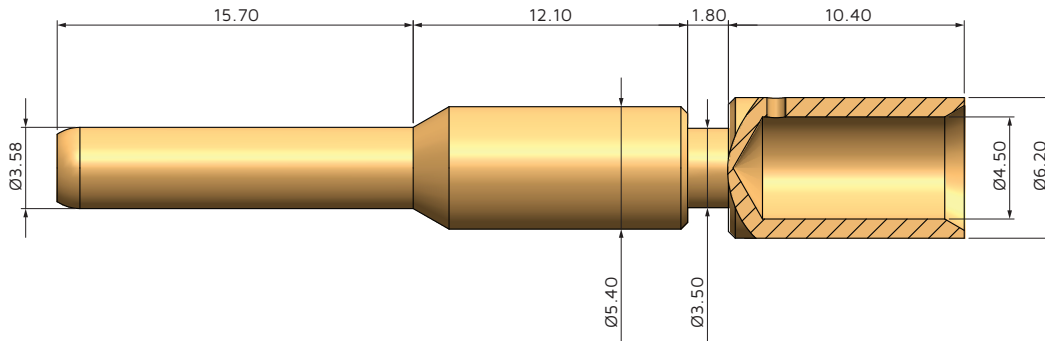

HYPP360C025G001

Ordering Number	Internal Part Number	Termination Style	Materials	Plating (μm)
HYPP360C025G001	213671020	Crimp	Brass	>0.25 gold

4.30 mm (0.170 in.) contacts

Female contacts (sockets)

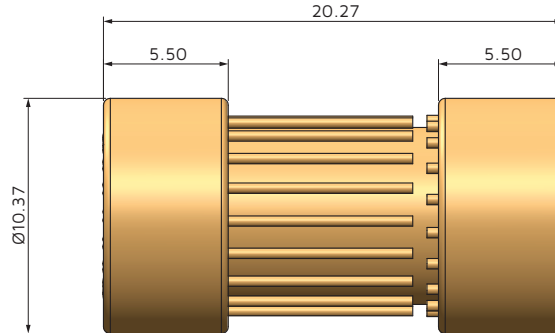

HYP54300127A001

Ordering Number	Internal Part Number	Termination Style	Contact Resistance (mΩ)	Current Rating (A)	Extraction Force (N)	Contact Life (cycles)	Materials	Plating (μm)
HYP54300127A001	YSK043-004AH	Open both ends	<0.35	100	25	Up to 100k	BeCu/Brass	>1.27 gold

Male contacts (pins)

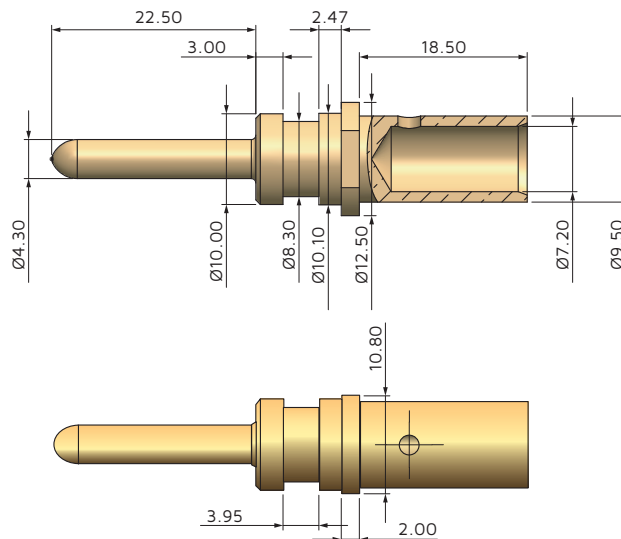

HYP430C127A001

Ordering Number	Internal Part Number	Termination Style	Materials	Plating(μm)
HYP430C127A001	YPN043-014RI	Crimp	Tellurium copper	>0.762 gold

6.12 mm (0.240 in.) contacts

Female contacts (sockets)

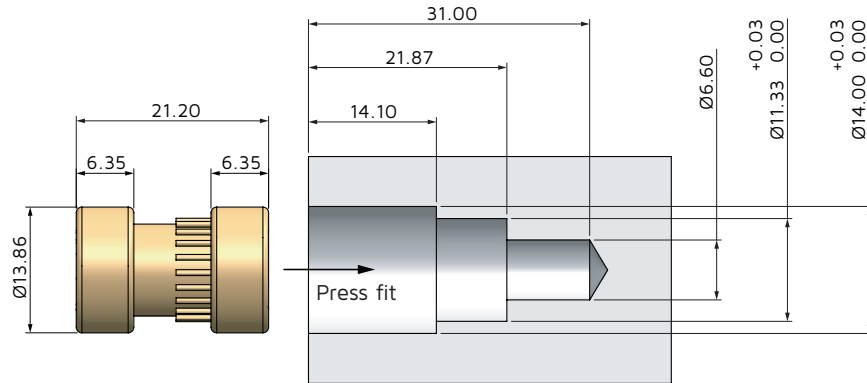

HYPS612O127A001

Ordering Number	Internal Part Number	Termination Style	Contact Resistance (m Ω)	Current Rating (A)	Extraction Force (N)	Contact Life (cycles)	Materials	Plating (μm)
HYPS612O127A001	HPG241F32AH	Open both ends	<0.25	200	44.5	Up to 100k	BeCu/Brass	>1.27 gold

Male contacts (pins)

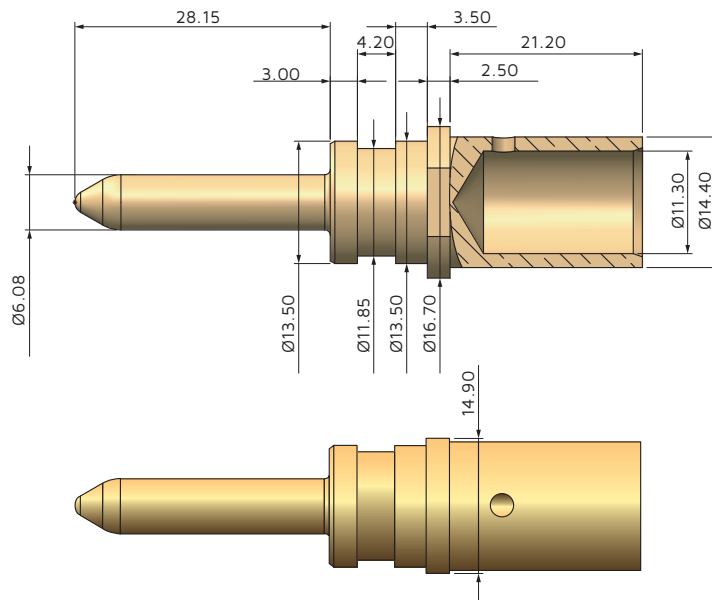

HYPP612C076A001

Ordering Number	Internal Part Number	Termination Style	Materials	Plating (μm)
HYPP612C076A001	YPN0612-027RI	Crimp	Tellurium copper	>0.762 gold

How to Order

	H	Y	P						
	1	2	3	4	5	6			
1 Series	H Y P Series (fixed)								
2 Contact type	S Socket								
	P Pin								
3 Contact diameter	0 4 0	0.40 mm (0,016 in.)	0 7 6	0.76 mm (0,030 in.)	1 2 0	1.20 mm (0,047 in.)	3 5 0	3.5 mm (0,12 in.)	
	0 5 0	0.50 mm (0,020 in.)	1 0 0	1.00 mm (0,039 in.)	1 5 0	1.50 mm (0,059 in.)	3 6 0	3.60 mm (0,14 in.)	
	0 6 0	0.60 mm (0,024 in.)	1 0 2	1.02 mm (0,040 in.)	2 0 0	2.00 mm (0,079 in.)	4 3 0	4.30 mm (0,17 in.)	
4 Termination style	C Crimp		E Closed end		U Solder cup				
	S Straight		O Open both ends						
5 Plating	Sockets				Pins				
	0 2 0	>0.2 µm gold	1 2 7	>1.27 µm gold	0 1 0	>0.1 µm gold	0 7 6	>0.762 µm gold	
	0 2 5	>0.25 µm gold			0 2 5	>0.25 µm gold	1 2 7	>1.27 µm gold	
6 Site*	A	G							
	I	F							
7 Sequence order*	0 0 1	Nr 1							
	0 0 2	Nr 2							
	0 0 3	Nr 3							

*: To be filled by the manufacturer.

Suggested Crimp Tools & Crimp Positioners

Ordering Number	Size mm	Crimp Tool	Crimp Positioner
HYPP040C127A001	0.4	AFM8*	T1914*
HYP040C127A001	0.4	AFM8*	T1914*
HYPP050C025A001	0.5	AFM8*	T870*
HYPP060C127A001	0.6	AFM8*	K547*
HYP0100C025I001	1.0	B-150 or B-151	B-055/A or B-200
HYPP100C010I001	1.0	AFM8* (M22520/2-01)	B-055
HYP0150C020F001	1.5	AF8*	SH 463*
HYP0150C025I001	1.5	AF8* (M22520/1-01)	SINT reference 15807

Ordering Number	Size mm	Crimp Tool	Crimp Positioner
HYPP150C127A001	1.5	FT8*	TP1650*
HYP0200C020F001	2.0	M317*	TP909*
HYPP250C127A001	2.5	M309*	TP1179*
HYPP350C127A001	3.5	WA23*	WA23-025*
HYPP360C025G001	3.6	B-152 or B-271	B-263
HYPP430C127A001	4.3	T1501*	T1535*
HYPP612C076A001	6.12	T1501*	T1536*

*Purchase from Daniels Manufacturing Corp direct

Worldwide Support

Connectors

Americas

Sales

connectors.uscsr@smithsinterconnect.com

Technical Support

connectors.ustechsupport@smithsinterconnect.com

Europe

Sales

connectors.emeacsr@smithsinterconnect.com

Technical Support

connectors.emeatechsupport@smithsinterconnect.com

Asia

Sales

asiacsr@smithsinterconnect.com

Technical Support

asiatechsupport@smithsinterconnect.com

Fiber Optics & RF Components

Americas

Sales

focom.uscsr@smithsinterconnect.com

Technical Support

focom.techsupport@smithsinterconnect.com

Europe

Sales

focom.emeacsr@smithsinterconnect.com

Technical Support

focom.techsupport@smithsinterconnect.com

Asia

Sales

focom.asiacsr@smithsinterconnect.com

Technical Support

focom.techsupport@smithsinterconnect.com

Semiconductor Test

Americas

Sales

semi.uscsr@smithsinterconnect.com

Technical Support

semi.techsupport@smithsinterconnect.com

Europe

Sales

semi.emeacsr@smithsinterconnect.com

Technical Support

semi.techsupport@smithsinterconnect.com

Asia

Sales

semi.asiacsr@smithsinterconnect.com

Technical Support

semi.techsupport@smithsinterconnect.com

RF/MW Subsystems

Americas, Europe & Asia

Sales

subsystems.csr@smithsinterconnect.com

Technical Support

subsystems.techsupport@smithsinterconnect.com

Connecting Global Markets

more > [smithsinterconnect.com](https://www.smithsinterconnect.com) | [in](#) [twitter](#) [youtube](#)