

Assembly Instructions

Disposable Plug Connector

REV B – D. Riveros, 01/26/2024

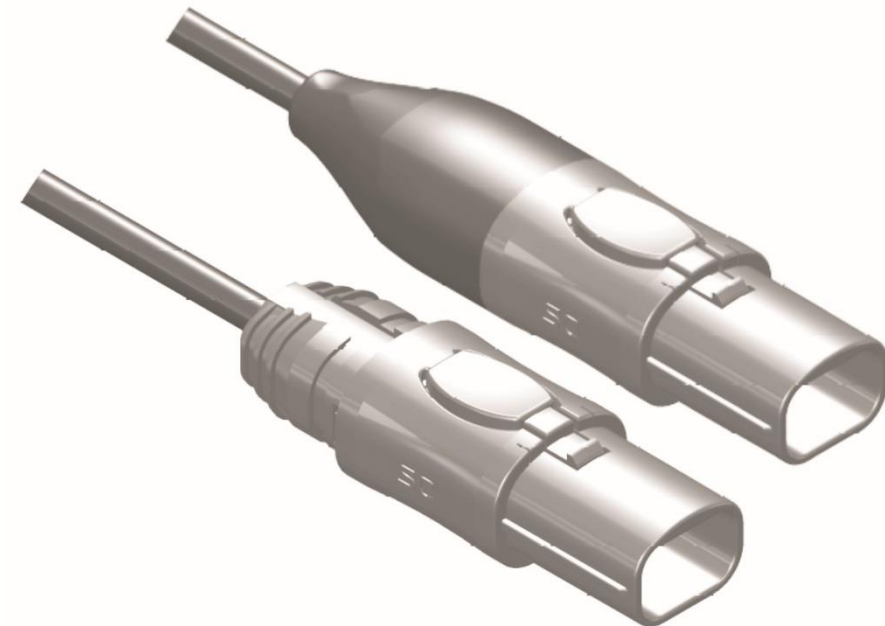

Assembly Instructions

Disposable Plug Connector

Disposable Plug Connector- Eclipta	
Connector Kit with PCB PN:	ECL34PD6XX
Connector Kit without PCB PN:	ECL34PD6XX-N
Connector Kit without Strain Relief Boot and with PCB PN:	ECL34ND6XX
Connector Kit without Strain Relief Boot and without PCB PN:	ECL34ND6XX-N
Standard PCB PN:	PCB0080
'X' represents all color-coding options and Keying Designations ('A' through 'F')	

Step 1: Slide strain relief boot (optional), plug latch, and cable clamp down cable as depicted below.

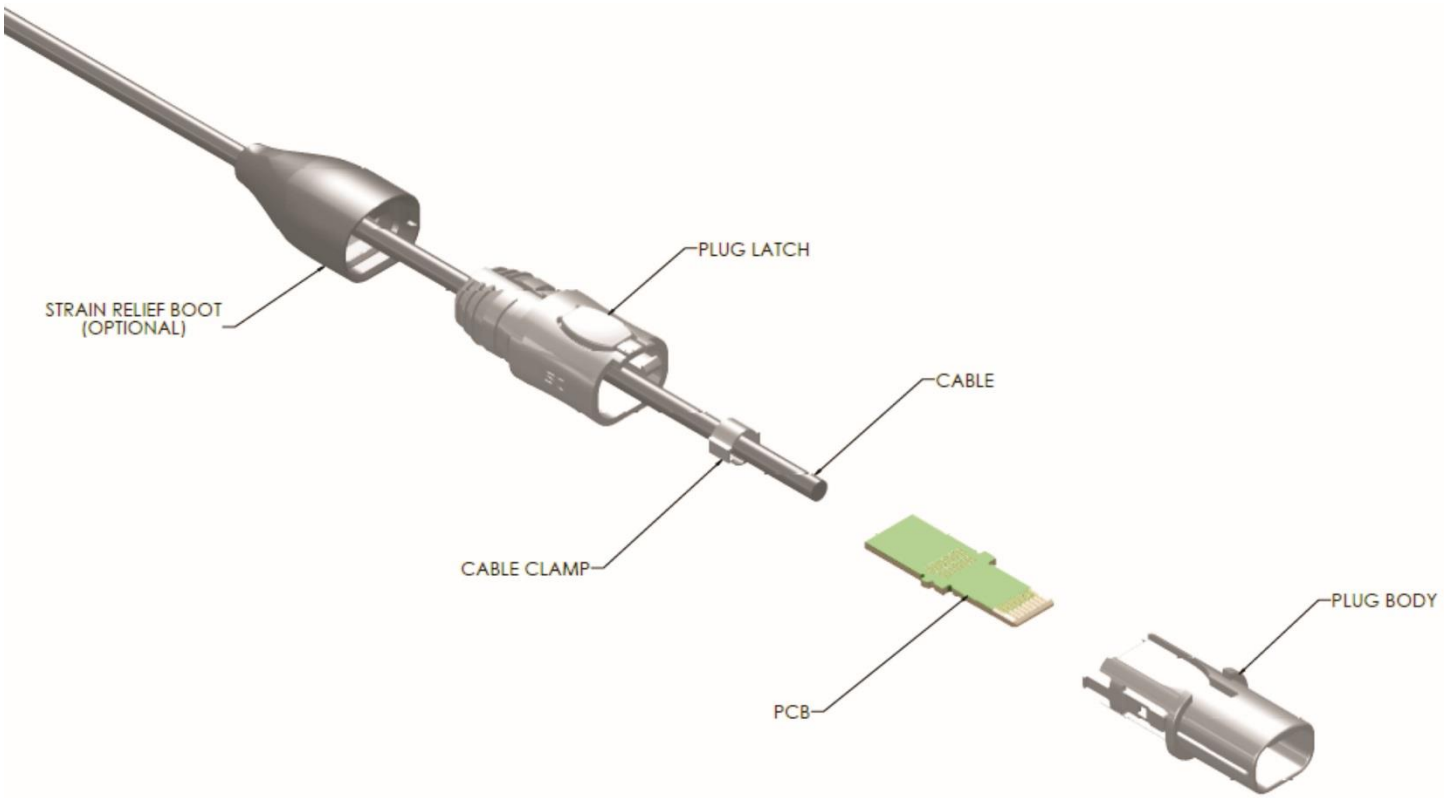

Step 2: Trim and strip cable and wires to length.

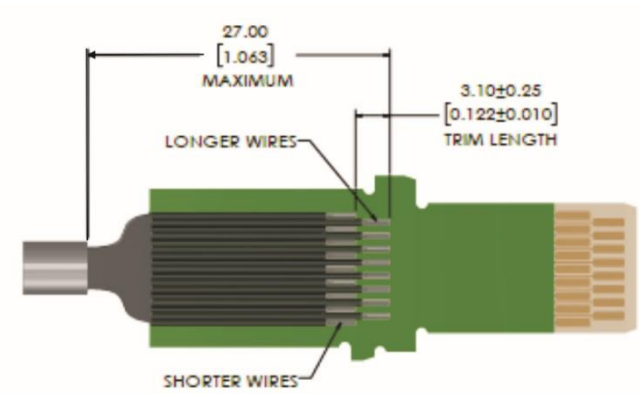
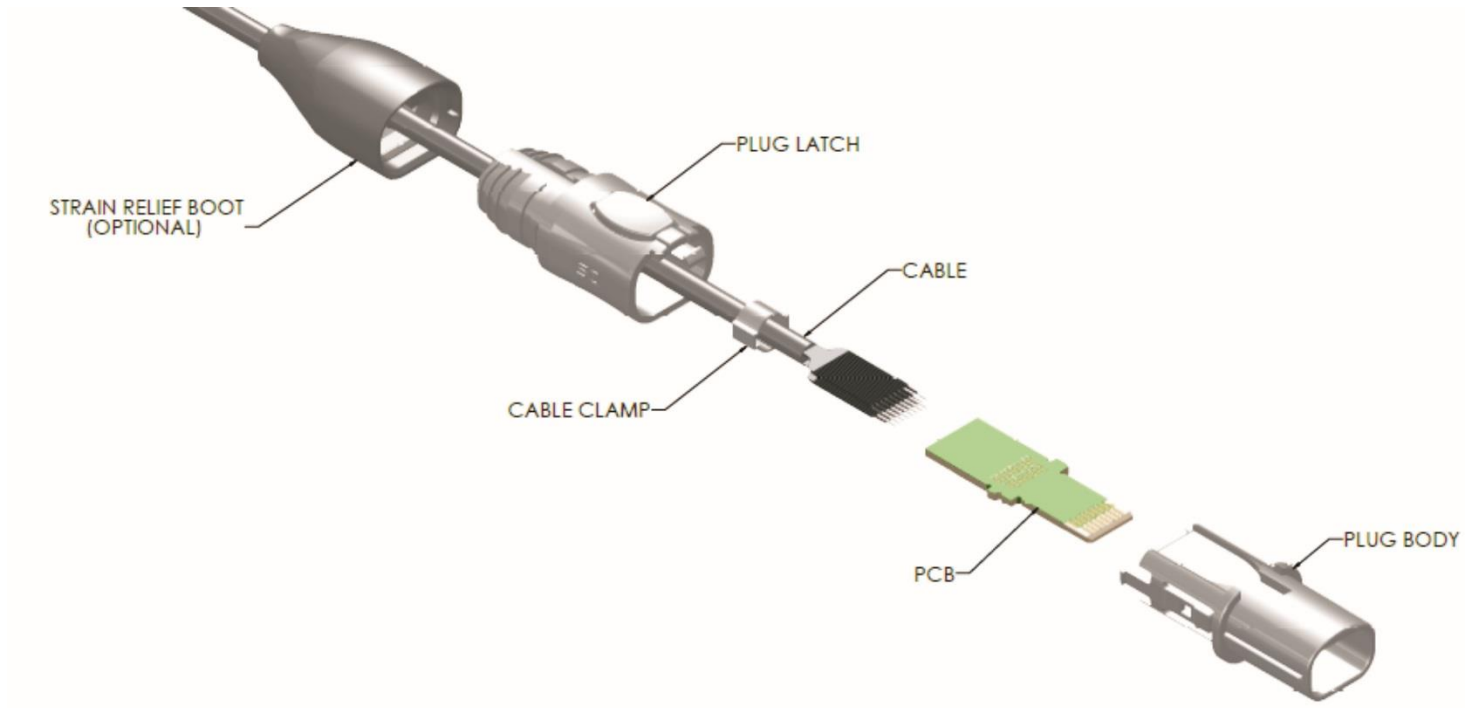

Wire/Cable Preparation		
	Strip Length [mm]	Trim Length [mm]
Shorter Wires	2.25 ± 0.25	3.10 ± 0.25
Longer Wires	2.25 ± 0.25	N/A
Cable	27.00 Maximum	N/A

Step 3: Solder wires onto PCB per wiring diagram (customer supplied).
Soldering shall conform to most recent revision of J-STD-001, Class 2 Product.

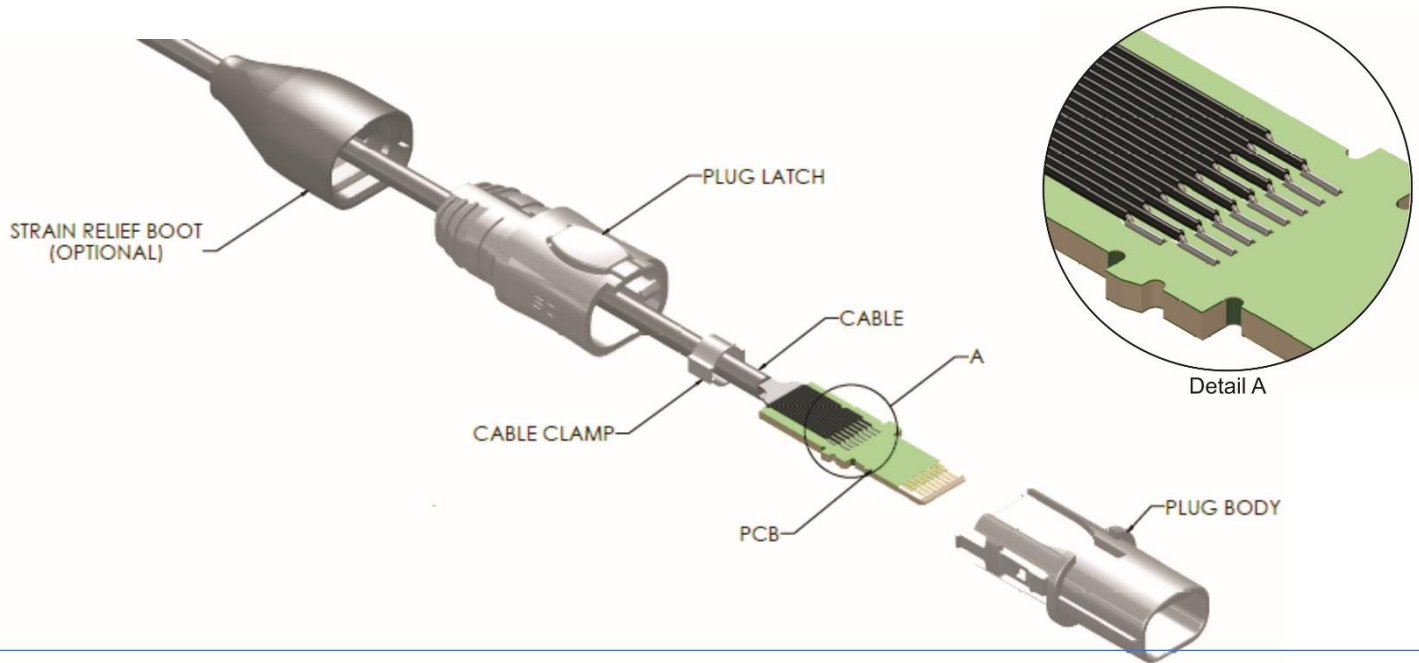

Step 4: Apply Epoxy over the soldered wire-connections and fully cure before moving onto the next step

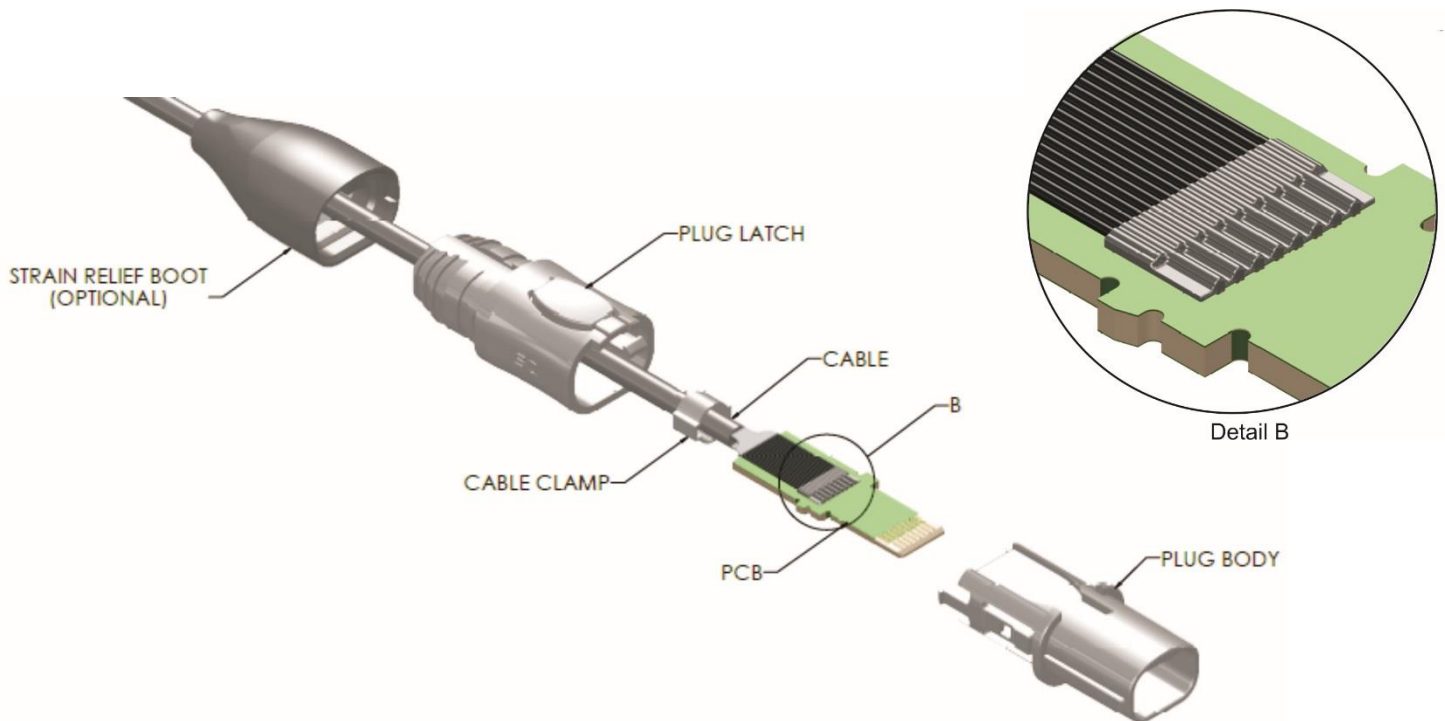

Step 5: Using OETIKER PN 14100082, compress cable clamp ears in place as depicted below. Cable clamp shall be located as shown in the images below. Orientation of cable clamp shall result in cable clamp ears being parallel with PCB, as depicted in the image "Detail C". Cable clamp shall not be able to slide after compressing. Zip-tie maybe applied in between the PCB and cable clamp to properly manage wires. Care shall be taken to prevent wires from moving relative to the cable jacket.

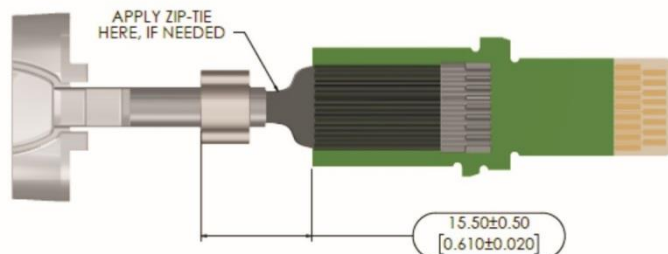
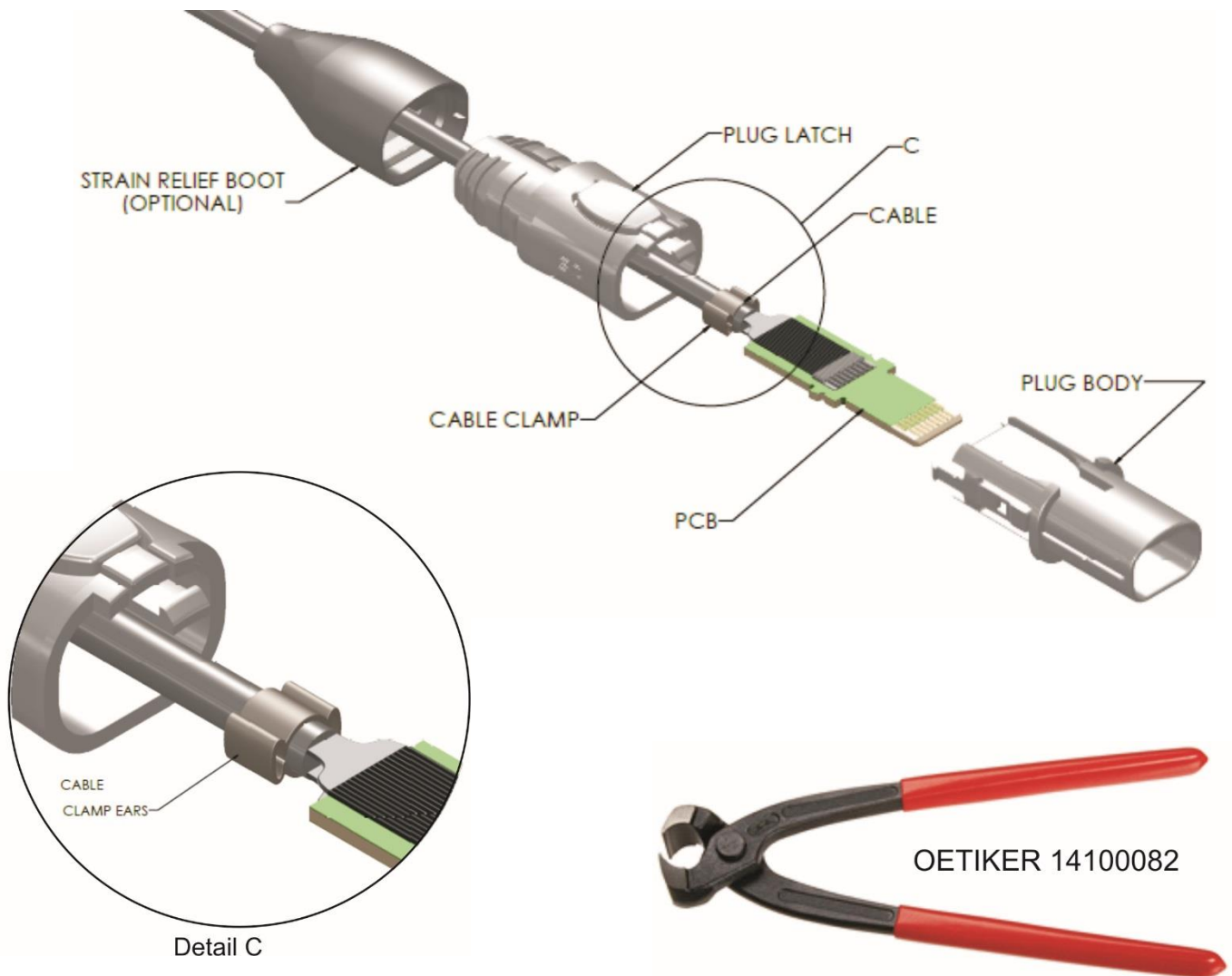

Step 6: Position PCB as depicted below, assuring the ears of the PCB are oriented relative to the top of the plug body in images below.

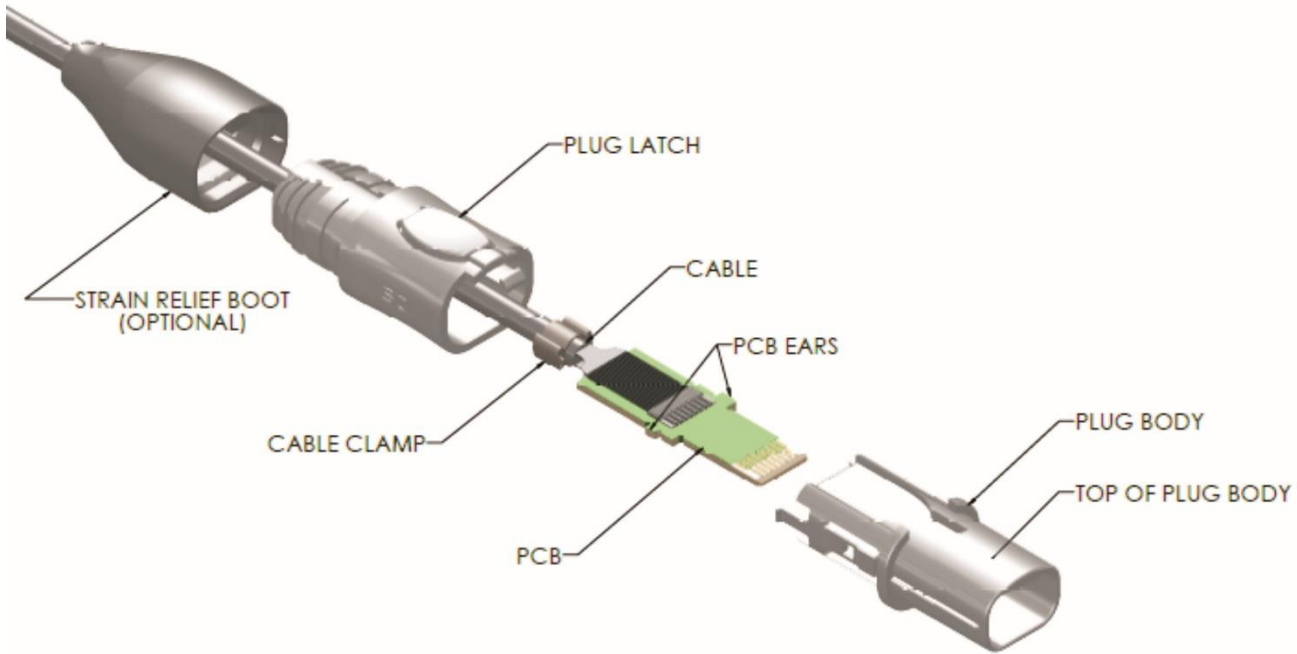

Install PCB into plug body until both ears of PCB snap into place

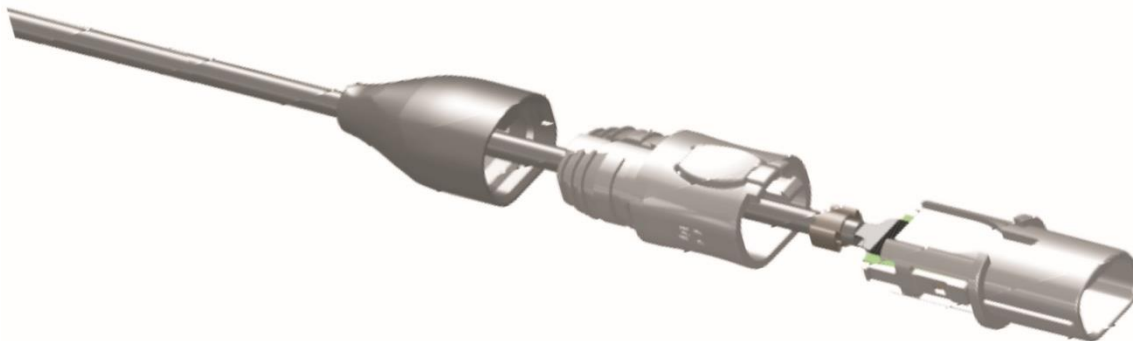

Step 7: Align plug latch alignment features with plug body alignment features and slide plug latch down cable until it bottoms out on the body and snaps into place. Latch alignment features may need a slight compression to allow successful snap installation.

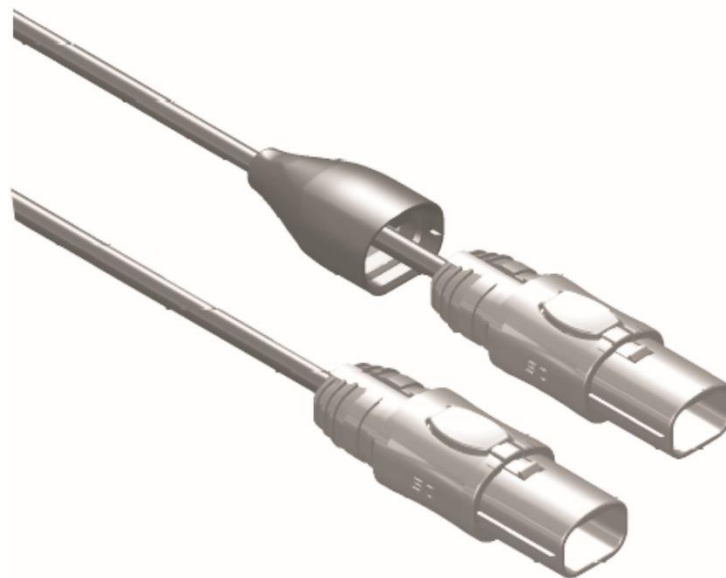
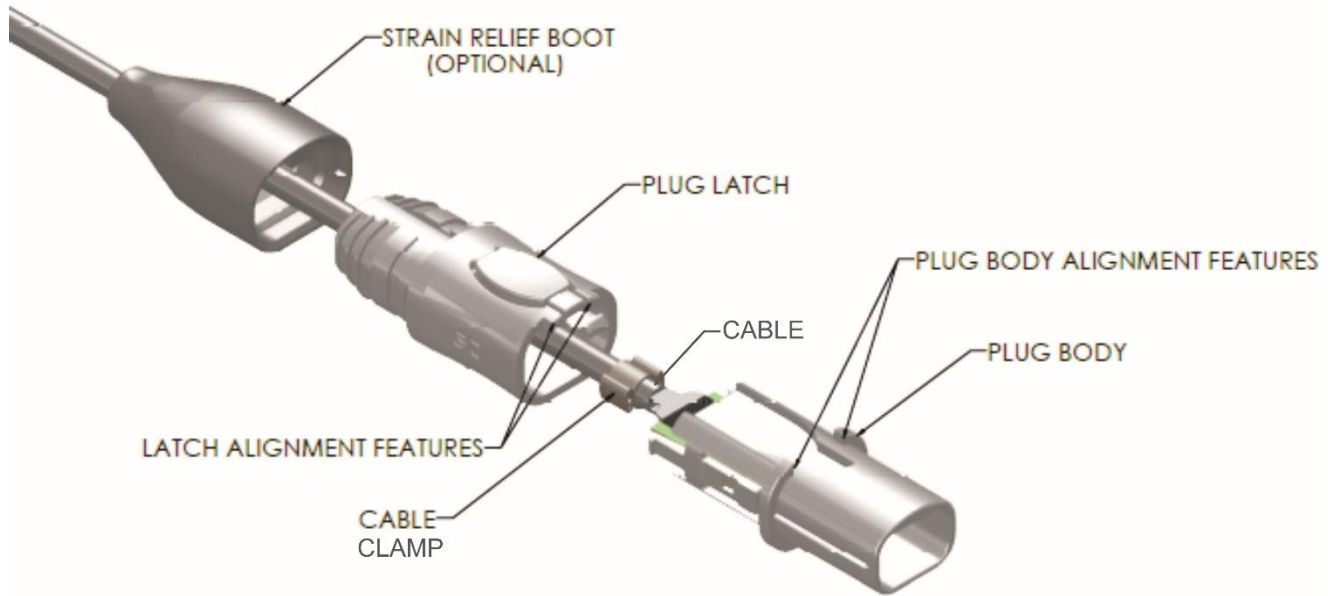

Step 8: If optional strain relief boot is used, align internal rib in boot with slot on plug latch, then slide strain relief boot down cable and push it onto the back end of plug latch until it fits snugly in place. If no strain relief boot is used, over-molding is required to ensure proper cable durability.

