

APPLICATION NOTE AN0028

DIY EQUALIZER USING EMC TECHNOLOGY'S TSXX ATTENUATOR FAMILY

Utilizing EMC Technology's standard attenuators the customer can create an equalizer network to compensate system frequency dependence. An equalizer can be made by attaching an inductor, either a chip inductor or a quarter wave length PCB etched line, at the ground terminal of an attenuator with the other port of the inductor connecting to circuit ground (Figure 3). At design frequency the quarter wave length inductor transforms the short to an open circuit, thus removing the shunt current path (Plot 1). If additional input matching is required an attenuator pad can be cascaded in front of the do-it-yourself (DIY) equalizer (Figure 4). To minimize forward and reverse reflection, an attenuator pad can be placed on both sides of the equalizer. Note that there is an associated insertion loss when using this equalizer topology; typically 1-2 dB can be seen depending on the attenuation value. Below is an example of a 10 dB pad at DC with a 2 dB positive slope equalization at 4 GHz.

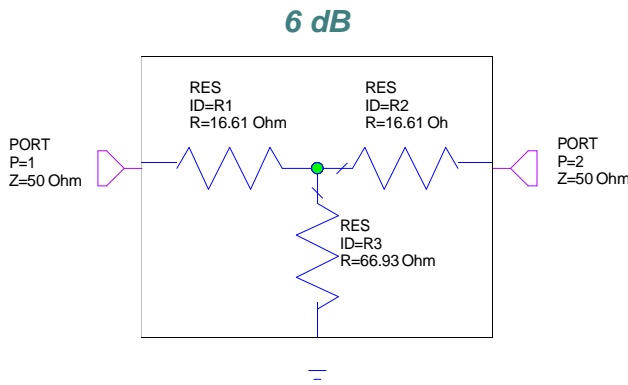

Figure 1

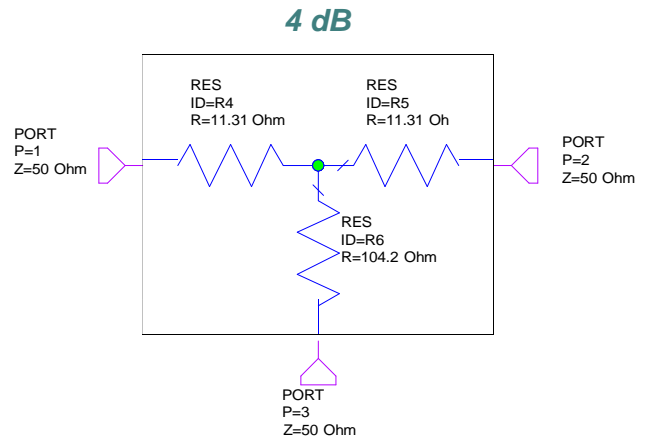

Figure 2

4 dB W/ INDUCTOR

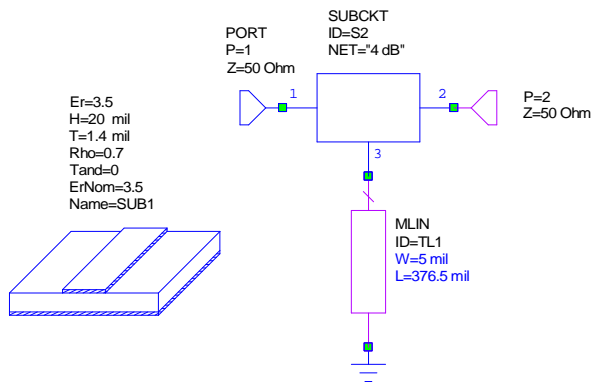

Figure 3

10 dB CASCADED

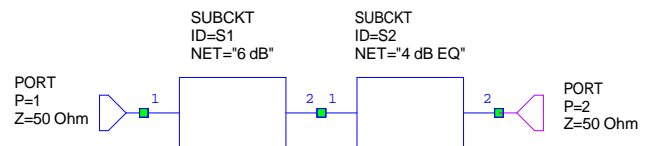
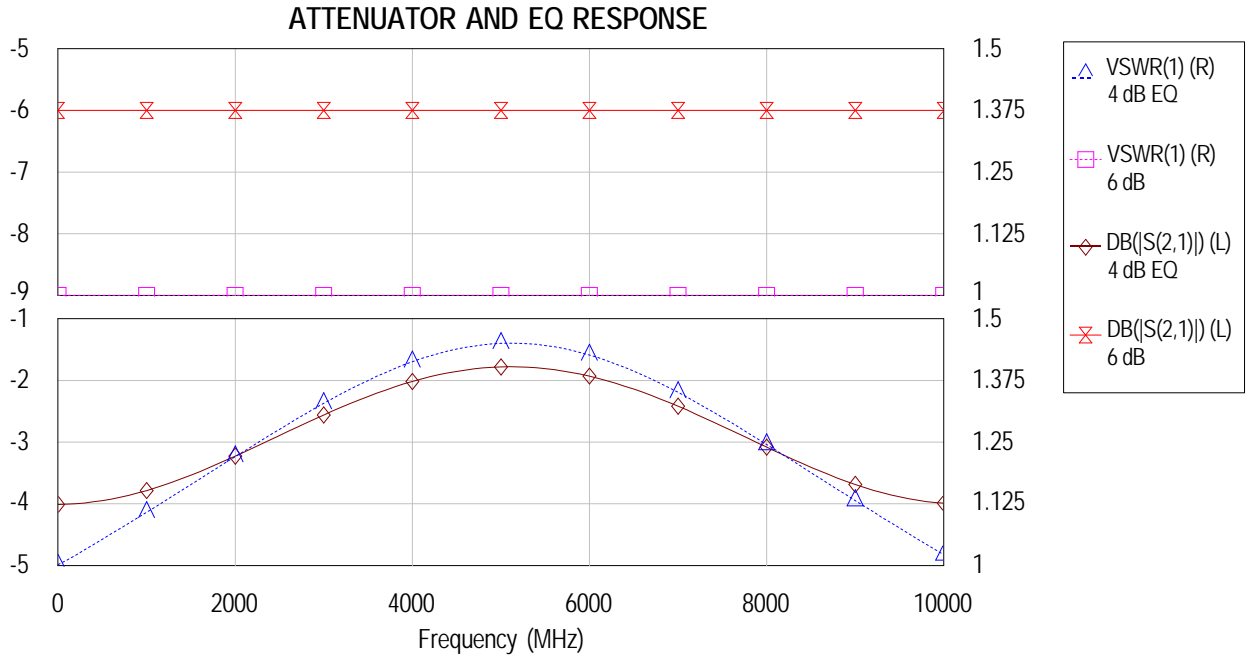

Figure 4

FREQUENCY EQUALIZATION USING ATTENUATORS

APPLICATION NOTE AN0028



Plot 1

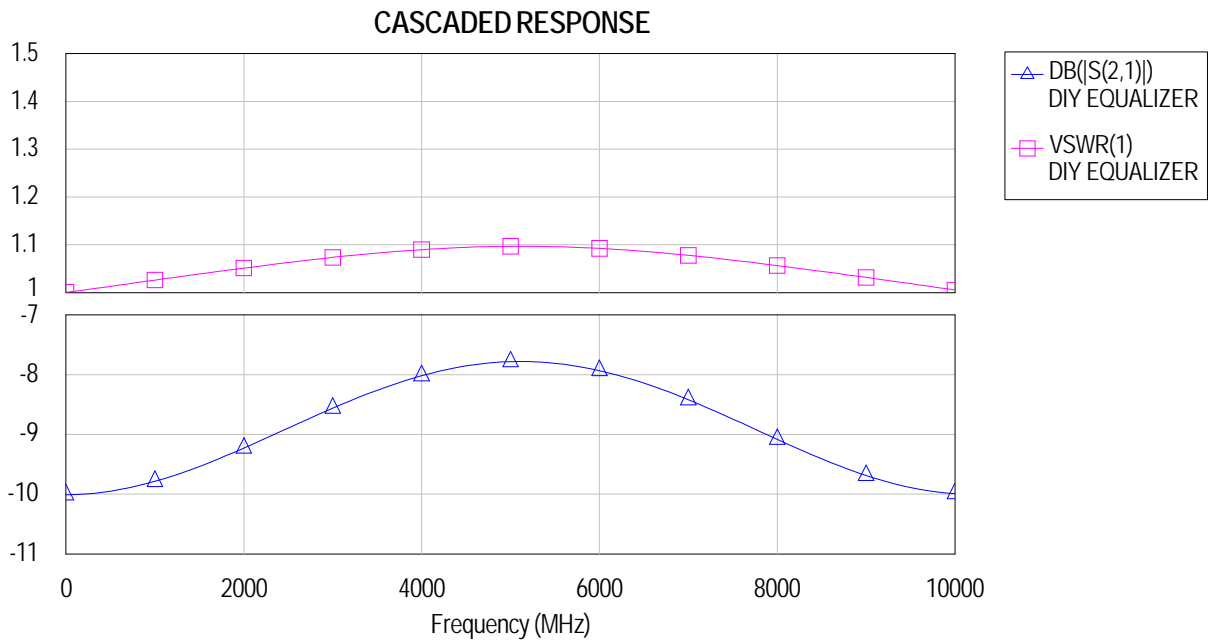

Plot 2