

C9394

PCB Connectors

High density in line replaceable module series



Hyperboloid Technology

Smiths Interconnect offers an extensive range of superior contact technologies suitable for standard and custom solutions. Hypertac® (HYPERboloid conTACT) is the original superior performing hyperboloid contact technology designed for use in all applications and in harsh and demanding environments where high reliability and safety are critical. The inherent electrical and mechanical characteristics of the Hypertac hyperboloid contact ensures unrivalled performance in terms of reliability, number of mating cycles, low contact force and minimal contact resistance. The shape of the contact sleeve is formed by hyperbolically arranged contact wires, which align themselves elastically as contact lines around the pin, providing a number of linear contact paths.

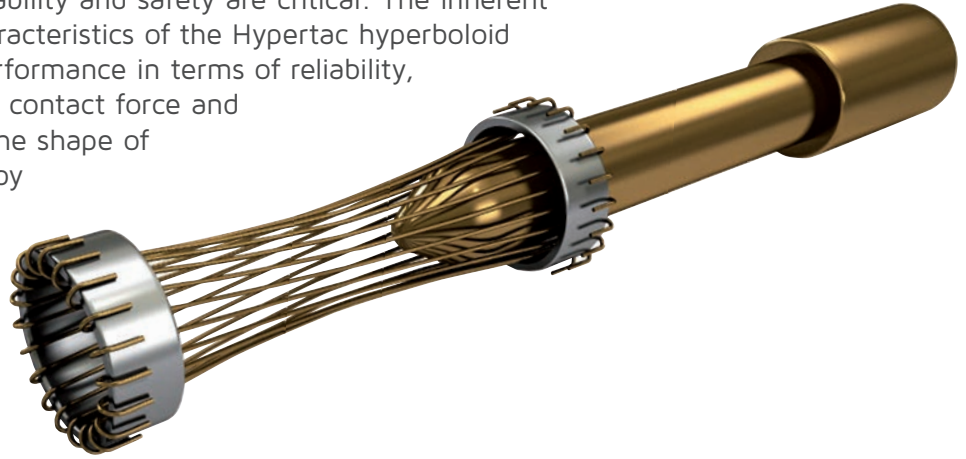

Features

Low insertion/extraction forces

The angle of the socket wires allows tight control of the pin insertion and extraction forces. The spring wires are smoothly deflected to make line contact with the pin.

Long contact life

The smooth and light wiping action minimizes wear on the contact surfaces. Contacts perform up to 100,000 insertion/extraction cycles with minimal degradation in performance.

Lower contact resistance

The design provides a far greater contact area and the wiping action of the wires insures a clean and polished contact surface. Our contact technology has about half the resistance of conventional contact designs.

Higher current ratings

The design parameters of the contact (e.g., the number, diameter and angle of the wires) may be modified for any requirement. The number of wires can be increased so the contact area is distributed over a larger surface. Thus, the high current carried by each wire because of its intimate line contact, can be multiplied many times.

Immunity to shock & vibration

The low mass and resultant low inertia of the wires enable them to follow the most abrupt or extreme excursions of the pin without loss of contact. The contact area extends 360° around the pin and is uniform over its entire length. The 3 dimensional symmetry of the Hypertac contact design guarantees electrical continuity in all circumstances.

Benefits

High density interconnect systems

Significant reductions in size and weight of sub-system designs. No additional hardware is required to overcome mating and un-mating forces.

Low cost of ownership

The Hypertac contact technology will surpass most product requirements, thus eliminating the burden and cost of having to replace the connector or the entire subsystem.

Low power consumption

The lower contact resistance of our technology results in a lower voltage drop across the connector reducing the power consumption and heat generation within the system.

Maximum contact performance

The lower contact resistance of the Hypertac contact reduces heat build-up; therefore Hypertac contacts are able to handle far greater current in smaller contact assemblies without the detrimental effects of high temperature.

Reliability under harsh environments

Harsh environmental conditions require connectors that will sustain their electrical integrity even under the most demanding conditions such as shock and vibration. The Hypertac contact provides unmatched stability in demanding environments when failure is not an option.

Contents

Series C9394

How to order.....	2
Scope	3
Applied documents.....	3
Requirements.....	3
Quality assurance provisions	5
Packaging	6
Typical arrangements of LRM connectors	6
Typical modules of LRM connectors	8
Contact type	11
Configuration	13
Plug connector, 150 contact positions	13
Receptacle connect, 150 contact positions	14
Plug connector, 300 contact positions.....	16
Receptacle connect, 300 contact positions.....	17
Plug connector, 450 contact positions.....	19
Receptacle connect, 450 contact positions.....	20
Extender board connectors.....	22
Plug connectors, dip solder.....	23
Maximum dimensions	24
The connector halves mating	25
Hardware code standard.....	26
C9394 series variation	28

How To Order

C9394 connectors are a LRM (in Line Replaceable Module) modular family. In the next pages are shown the requested version with their order reference. For example [see page 12: Ref. Order C9394/17058](#)

If the connector is not represented in the pages of this catalogue but you find at page 8+9 an interesting module, contact the factory and communicate the followings information:

- number of way
- type insert
- type of contact terminal
- thickness of board (if you chooses the terminal SMT soldering)
- type of hardware code
- forecast of purchase (for next 2 years)

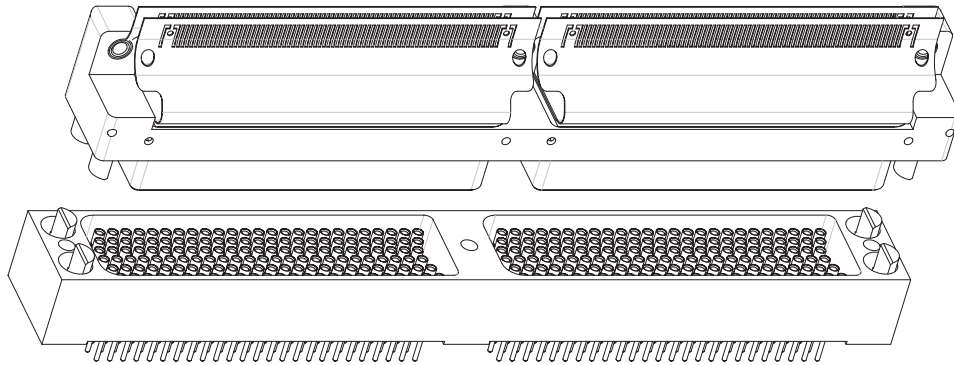

1. Scope

1.1 Scope

This Design covers C9394 metal shelled Connectors Family, plug and receptacle style, 132 thru 594 pin or socket contact positions, proven to MIL-DTL-55302 performance standards. Contact arrangement is chevron pattern within each dielectric insert with six rows, .075 in (1.905 mm) center-to-center contact spacing in each row, and .075 in (1.905 mm) row-to-row spacing. Contact size is 0.6 mm nominal pin DIA. Polarization feature is incorporated in each connector assembly to assure correct insertion. Coding key system provides 256 possible keying combinations. There are available, moreover, suitable insert cavities aimed at ground contacts, shielded contacts, co-axial contacts, databus contacts, fiber optic termini, etc.

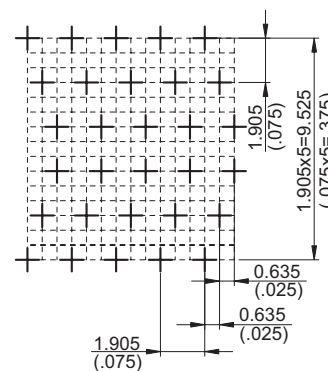

1.2 Contact terminal types

Plug connector, pin contacts equipped, is available assembled with flex-circuit conforming to MIL-P-50884 and its surface mount tails are the contact terminals for straddle mount, (daughterboard attachment) or with solder post, thru hole, as contact terminals, for rigid PWB. Receptacle connector, socket contacts equipped, is available with thru hole, as contact terminal for rigid PWB, (motherboard attachment) or with wire wrap posts, in accordance with MIL-STD-1130, as contacts terminals (backplane attachment). Receptacle connector, socket contacts equipped, is available, moreover, assembled with flex-circuit conforming to MIL-P-50884, and its surface mount tails are the contact terminals for straddle mount, (extender-board application, or in line board-to-board packaging).

2. Applied documents

2.1 Applied documents

C9394 Connectors Family is designed, manufactured, tested and delivered in accordance with the documents listed below. The latest issue and amendments in being on 30 June 1994 are used unless otherwise specified in this Design.

- MIL-C-26074 Coatings, electroless nickel requirement for.
- MIL-I-46058 Insulating compound, electrical (for coating printed circuit assemblies).
- MIL-P-50884 Printed-wiring, flexible and rigid-flex. sostituita da IPC-6013.
- MIL-DTL-55302 Connectors, printed circuit subassembly and accessories.
- MIL-I-81550 Insulating compound electrical, embedding, reversion resistant silicone.
- IPC-2223 Sectional design standard for flexible printed boards and IPC-2221 generic standard on printed board design.
- NASM21209 Insert, screw thread, coarse and fine, screw locking, helical coil, cres.

3. Requirements

3.1 Dielectric insert is an insulator body of molded one-piece construction.

3.1.1 Dielectric insert material is injection molded from glass reinforced polyphenylene sulfide (PPS) type GST-40F per MIL-M-24519 and in accordance with MIL-DTL-55302. This thermoplastic compound is flame resistant, having flammability rating V-O/5VA, without additives, per UL94.

3.2 Pin contact and contact termination

3.2.1 Pin contact and its surface mount tail termination are two-pieces construction type. These two-parts are assembled using a suitable tin-lead soldering.

Pin contact is screw machined from copper-alloy per ASTM-B-16 with protective finishing of gold plate, over suitable underplate, as specified in MIL-DTL-55302. The surface mount tail termination is the part of a proper flex-circuit conforming to MIL-P-50884 with tail finishing of tin-lead (50-70%) composition, .50 to .80 mil (12 to 20 micron) thick, per SAE AMSP81728 plating, tin-lead (electrodeposited).

3.2.1.1 Solder alloy composition.

Pin contact is soldered with flex-circuit, as its contact termination, using solder alloy composition Sn63 conforming to QQ-S-571 soldered connections are coated using conformal coating per MIL-I-46058 type UR.

3.2.2 Pin contact and dip solder straight-thru, contact terminal are screw machined, and one-piece construction, from copper-alloy per ASTM-B-16, with protective finishing of gold plate, over suitable underplate, as specified in MIL-DTL-55302.

3.3 Socket contact and contact termination

Socket contact is HYPERTAC, and contact terminal types are: dip solder, (straight), wire wrappost, surface mount tail.

3.3.1 Socket contact materials.

HYPERTAC springs are wire drawn from beryllium-copper alloy per ASTM-B-196. Socket contact body is screw machined from copper-alloy per ASTM-B-16. Protective finishing is gold plate, over suitable underplate, as specified in MIL-DTL-55302.

3.3.2 Dip solder, wire wrappost contact terminations are screw machined from suitable copper-alloys in accordance with MIL-DTL-55302, with protective finishing of gold plate, over suitable underplate, as specified in MIL-DTL-55302. Hot solder dipping, as dip solder termination end finishing, is available at Customer request.

3.3.3 Socket contact and its surface mount tail terminal are two-pieces construction type. These two-parts are assembled in one-piece construction using a suitable tin-lead soldering.

The surface mount tail termination is the part of a proper flex-circuit conforming to MIL-P-50884 with tail finishing of tin-lead (50÷70%) composition, .50 to .80 mil (12 to 20 µm) thick, per SAE AMS-P-81728.

3.3.3.1 Solder alloy composition.

Socket contact is soldered with flex-circuit, as its contact terminal, using solder alloy composition Sn63 conforming to QQ-S-571.

3.4 Connector hardware standard consists of eight coding keys (four supplied together plug connector and four together receptacle connector) in injection molded from thermoplastic polyester compound, 30% glass reinforced, in accordance with type GPT-30 of MIL-M-24519. It is possible substitute a pair of coding key with two guide pin/socket or two screw locking machined from stainless steel per ASTM-A-582 and passivated per ASTM-A-967.

3.5 Plug and receptacle shells are machined from aluminium alloy per AMSQQA250/4 and finished with electroless nickel coating per MIL-C-26074.

3.5.1 Joining devices are corrosion-resistant steel per ASTM-A-693 and passivated per ASTM-A-967. Threaded insert, self-locking type, are conforming to MS21209.

3.6 Design and construction of C9394 Connectors Family are in accordance with MIL-DTL-55302 requirements.

3.7 C9394 Connectors Family requirements are:

- contact engagement and separation forces: maximum engagement force =70 g (2.47 oz); minimum separation force =7 g (.25 oz);
- connector mating and unmating forces: maximum mating force =60 g (1.76 oz) multiplied by number of contacts; minimum unmating force =15 g (.53 oz) multiplied by number of contacts;
- contact current rating: the connector may have any combination of current flow and ambient temperature provided the contact or connector temperature does not exceed 150 °C.
The test current is 2.0 A for individually connected contact, and 1.0 A for series wired contacts; current rating of the contacts equipped with flex circuit termination shall be as per the requirements of MIL-P-50884 (MIL-STD-2118) for cross section 0.01 mm².
- mated contact resistance: 10.0 mΩ maximum individual, if pin and socket contacts have dip solder, or wire wrappost, as contact termination
- the flex-circuit resistance plus the soldering resistance, (namely surface mount tail terminal resistance), 30 mΩ maximum individual
- the total resistance equals the surface mount tail terminal resistance plus the mated contact resistance;
- temperature range: normal operating temperature is between -65 °C and +150 °C;
- dielectric withstanding voltage: 1000 VRMS, 60 Hz at sea level, 250 VRMS, 60 Hz at 70,000 feet (21,336 m), when flex-circuit and its surface mount tails are conformally coated of a suitable electrical insulating compound as specified in MIL-I-46058;
- insulation resistance is ≥ 5000 MΩ at 500 VDC;
- contact life: 30,000 insertion and withdrawal cycles, with minimum wear;
- vibration: when tested in accordance with MIL-DTL-55302, and MIL-STD-1344 method 2005, 10-2000 Hz, 15 G peak, 4 h per axis, 100 mA, there are no interruption in continuity greater than 2 ns of the test circuit which incorporates mated contacts;
- shock: when tested in accordance with MIL-DTL-55302, and MIL-STD-1344 method 2004, 6 ms, 100 G sawtooth, six shocks, 100 mA, there are no interruption in continuity greater than 2 ns of the test circuit which incorporates mated contacts;
- solderability: in accordance with MIL-STD-202 method 208 at a uniform temperature of 245 °C for 5 s;
- resistance to soldering heat: in accordance with MIL-STD-202 method 210 condition C, 260 °C for 10 s;
- capacitance: contact to contact maximum 1.5 pF; contact to shell maximum 2.0 pF;
- calculated inductance: maximum 15 nH.





















4. Quality assurance provisions

C9394 Connectors Family is inspected using data values of Section 3 of this Design, and examinations and test methods in accordance with MIL-DTL-55302.

5. Packaging

5.1 Packaging requirements are in accordance with "Smiths Interconnect Packaging Procedures", and then packaging is adequate to provide protection against any damage, breakage, or loss during shipment from the supply source to the ultimate using activity.

Typical Arrangement of LRM Connectors

Number bay	Arrangements	Notes
Single bay	 100 Contacts	Ask factory for details
	 132 Contacts	See the following pages
	 150 Contacts	Ask factory for details
	 198 Contacts	Ask factory for details
	 15 Coax	Ask factory for details
	 4(6) Triaxial	See the following pages
Double bay	 100 Contacts 100 Contacts	Ask factory for details
	 132 Contacts 132 Contacts	See the following pages
	 150 Contacts 150 Contacts	Ask factory for details
	 150 Contacts 150 Contacts	Ask factory for details
	 15 Coax 15 Coax	Ask factory for details
	 4(6) Triaxial 4(6) Triaxial	Ask factory for details
	 100 Triaxial 15 Triaxial	Ask factory for details
	 132 Contacts 15 Coax	Ask factory for details
	 100 Contacts 4(6) Triaxial	Ask factory for details
	 132 Contacts 4(6) Triaxial	Ask factory for details
	 150 Contacts 15 Coax	Ask factory for details
	 150 Contacts 4(6) Triaxial	Ask factory for details
 198 Contacts 15 Coax	Ask factory for details	
 198 Contacts 4(6) Triaxial	Ask factory for details	

Number bay	Arrangements	Notes
Triple bay		Ask factory for details
		See the following pages
		Ask factory for details
		Ask factory for details
		Ask factory for details
		Ask factory for details
		Ask factory for details
		Ask factory for details
		Ask factory for details
		Ask factory for details
		Ask factory for details
		Ask factory for details
		Ask factory for details
		Ask factory for details
		Ask factory for details
		Ask factory for details
		Ask factory for details
		Ask factory for details
		Ask factory for details
		Ask factory for details
	Ask factory for details	
	See the following pages	

Typical Modules of LRM Connectors

Contact position	Connector style/ manufacture		Contact Terminal Types available are:		
			Dip Solder Straight-Thru	Surface Mount Tail	Wire Wrap Post
100	Plug (Moulded)		Yes	Yes	No
	Receptacle (Moulded)		Yes	Yes	Yes
132	Plug (Moulded)		Yes	Yes	No
	Receptacle (Moulded)		Yes	Yes	Yes

Contact position	Connector style/ manufacture		Contact Terminal Types available are:		
			Dip Solder Straight-Thru	Surface Mount Tail	Wire Wrap Post
150	Plug (Moulded)		Yes	Yes	No
	Receptacle (Moulded)		Yes	Yes	Yes
198	Plug (Moulded)		Yes	Yes	No
	Receptacle (Moulded)		Yes	Yes	Yes

Contact position	Connector style/ manufacture		Contact Terminal Types available are:
15	<p>Plug (Machined)</p>		<p>They can be supplied with coax or power contacts conforming to UTE C93-569 model KM X3.</p> <p>The contact must be order separately</p>
	<p>Receptacle (Machined)</p>		
4	<p>Plug (Machined)</p>		<p>Dielectric inserts with 4 triaxial size 10 contact cavities.</p> <p>The contact must be order separately</p>
	<p>Receptacle (Machined)</p>		
6	<p>Plug (Machined)</p>		<p>Dielectric inserts with 6 triaxial size 12 contact cavities.</p> <p>The contact must be order separately</p>
	<p>Receptacle (Machined)</p>		

Note: In the following pages of the catalogue are shows the basic configurations using 150 ways module.

Contact Type

Standard terminations

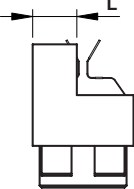
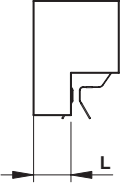
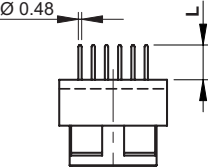
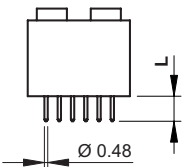
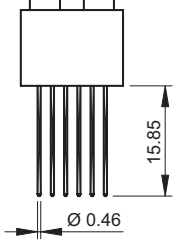
Male	Description	Female
	<p>Male and female contact with SMT terminal</p> <p>Pcb 1.30÷2.30 L=6.35 Pcb 2.30÷3.25 L=5.85 Pcb 3.25÷4.20 L=5.35 Pcb 4.00÷5.00 L=5.00 Pcb 4.60÷5.80 L=4.65</p> <p>Lead dimensions</p>	
	<p>Male and female contact with dip solder, straight true</p> <p>L=5.00 L=3.60</p>	
	<p>Female contact wire wrap post</p>	

Triaxial contact

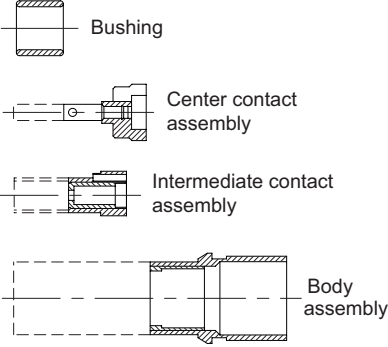
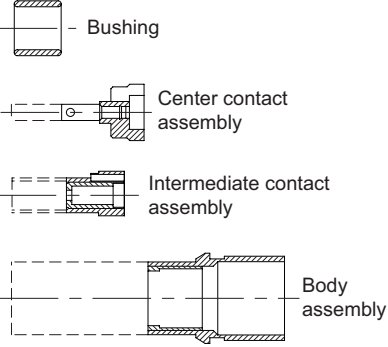
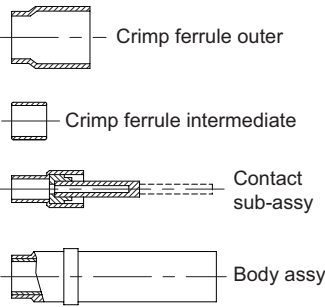
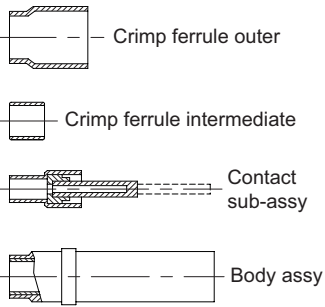
Male	Description	Female
	<p>Ref. order. 018812-2008</p> <p>Pin/Socket contact triaxial size 10 crimp terminal style for PAN6421 cable.</p> <p>Please consult the factory to crimp instruction and crimp tool.</p> <p>Ref. order. 018912-2008</p>	
	<p>Ref. order. 018612-2016</p> <p>Pin/Socket contact Triaxial Size 12 crimp terminal style.</p> <p>Please consult the factory to crimp instruction and crimp tool.</p> <p>Ref. order. 018712-2016</p>	

Power and coax contact

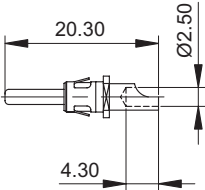
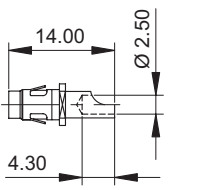
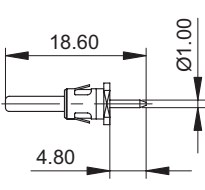
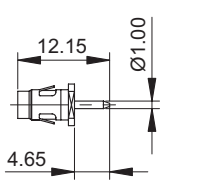
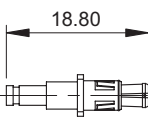
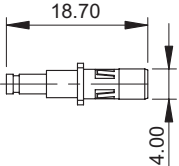
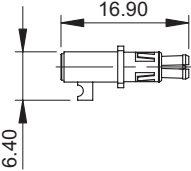
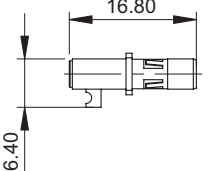
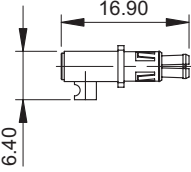
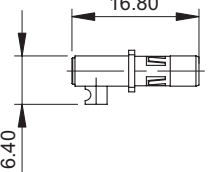
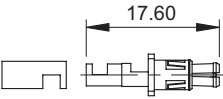
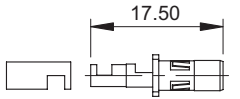
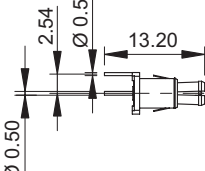
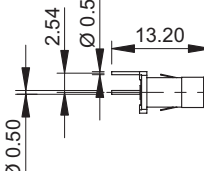
Male	Description	Female
	<p>Ref. order: CXM321</p> <p>Male and female power contact with solder termination. Please consult the factory to crimp instruction and crimp tool.</p> <p>Ref. order: CXF321</p>	
	<p>Ref. order: CXM341</p> <p>Male and female power contact with straight PCB termination. Please consult the factory to crimp instruction and crimp tool.</p> <p>Ref. order: CXF341</p>	
	<p>Ref. order: CXM021</p> <p>Male and female coax contact with solder termination suitable for flexible cable Ø est. 2.00 mm. Ref. KX 21 A/RG 196 AU. Please consult the factory to crimp instruction and crimp tool.</p> <p>Ref. order: CXF021</p>	
	<p>Ref. order: CXM012</p> <p>Male and female coax contact with solder termination, 90° cable entry, suitable for flexible cable Ø est. 2.00 mm. Ref. KX 21 A/RG 196 AU. Please consult the factory to crimp instruction and crimp tool.</p> <p>Ref. order: CXF012</p>	
	<p>Ref. order: CXM052</p> <p>Male and female coax contact with solder termination, 90° cable entry, suitable for semi-rigid cable Ø est. 2.16 mm. Ref. KS 1/RG 405 U. Please consult the factory to crimp instruction and crimp tool.</p> <p>Ref. order: CXF052</p>	
	<p>Ref. order: CXM061</p> <p>Male and female coax contact with solder termination suitable for semi-rigid cable Ø est. 2.16 mm. Ref. KS 1/RG 405 U. Please consult the factory to crimp instruction and crimp tool.</p> <p>Ref. order: CXF061</p>	
	<p>Ref. order: CXM041</p> <p>Male and female with straight p.c.b. termination (PCB thickness 3.2 max). Please consult the factory to crimp instruction and crimp tool.</p> <p>Ref. order: CXF041</p>	

Configurations

Plug connector, 150 contact positions, surface mount tail contact terminal style

Plug connector, 150 pin contacts, surface mount tail terminal style, board package thickness from 1.30 to 5.80

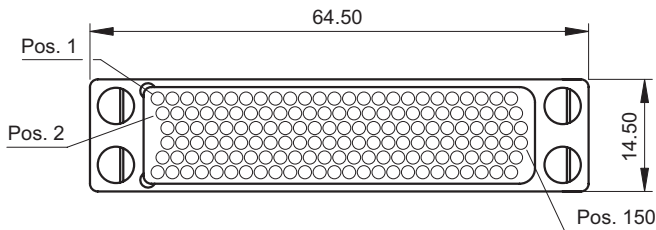

PCB 1.30+2.30 L=6.35	Ref. ord. C9394/18034
PCB 2.30+3.25 L=5.85	Ref. ord. C9394/16691
PCB 3.25+4.20 L=5.35	Ref. ord. C9394/18035
PCB 4.00+5.00 L=5.00	Ref. ord. C9394/18036
PCB 4.60+5.80 L=4.65	Ref. ord. C9394/18037

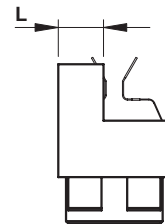
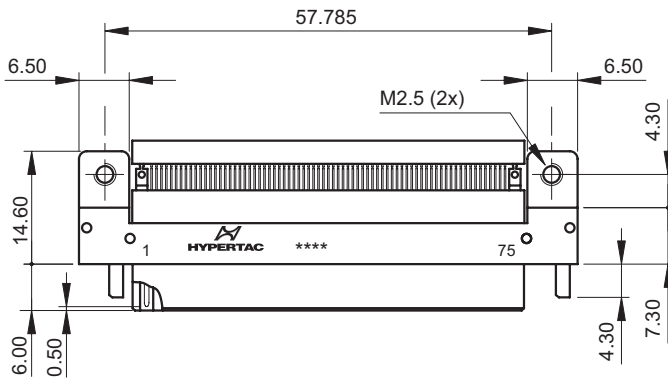

Mounting pattern, daughterboard application

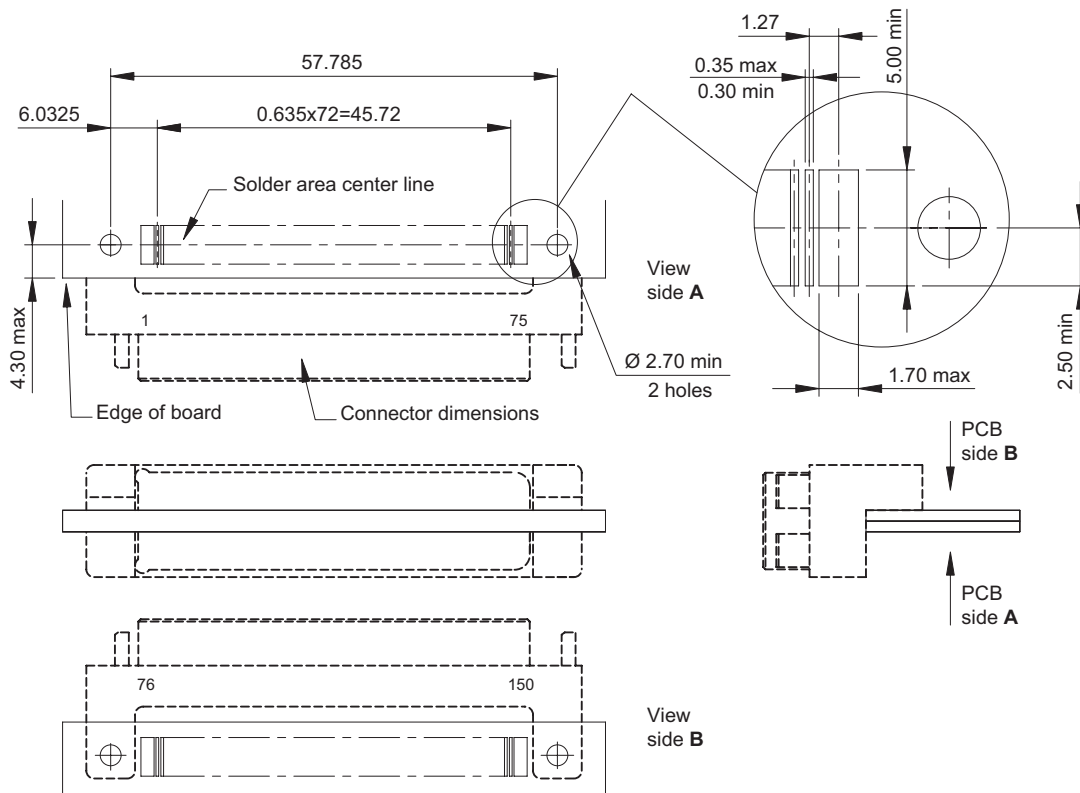

Receptacle connector, 150 contact positions, dip solder contact terminal style

Receptacle connector, 150 socket contacts, dip solder (straight) contact terminal style

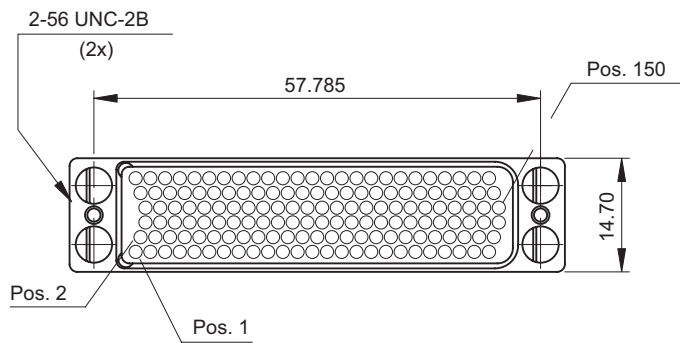
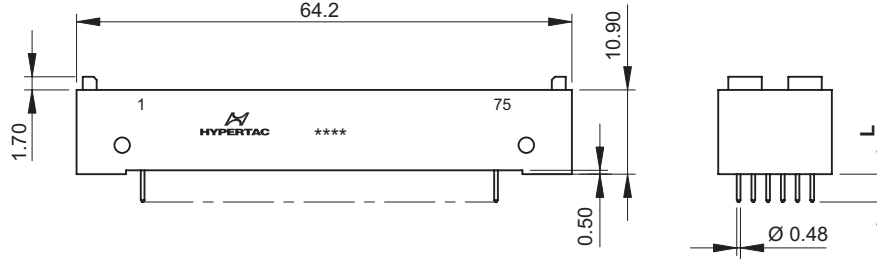

L=3.60 Ref. ord. C9394/16659
L=5.00 Ref. ord. C9394/17072

Mounting pattern, motherboard application

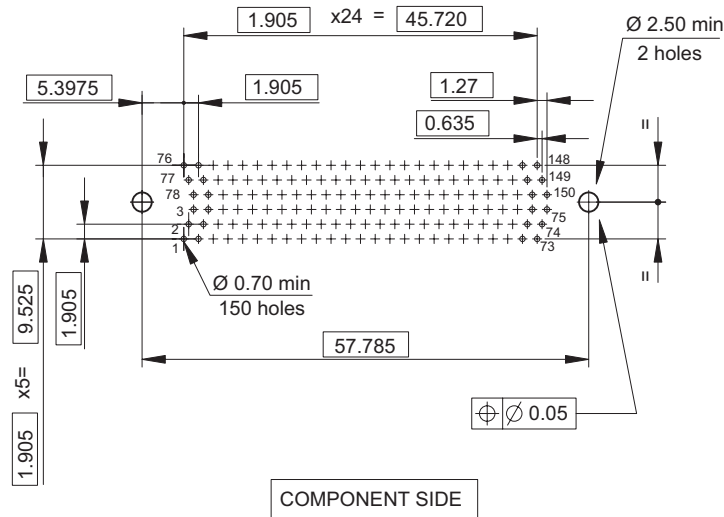

COMPONENT SIDE

Receptacle connector, 150 contact positions, wire wrap post contact terminal style

Connector receptacle, 150 socket contacts, wire wrap post contact terminal style

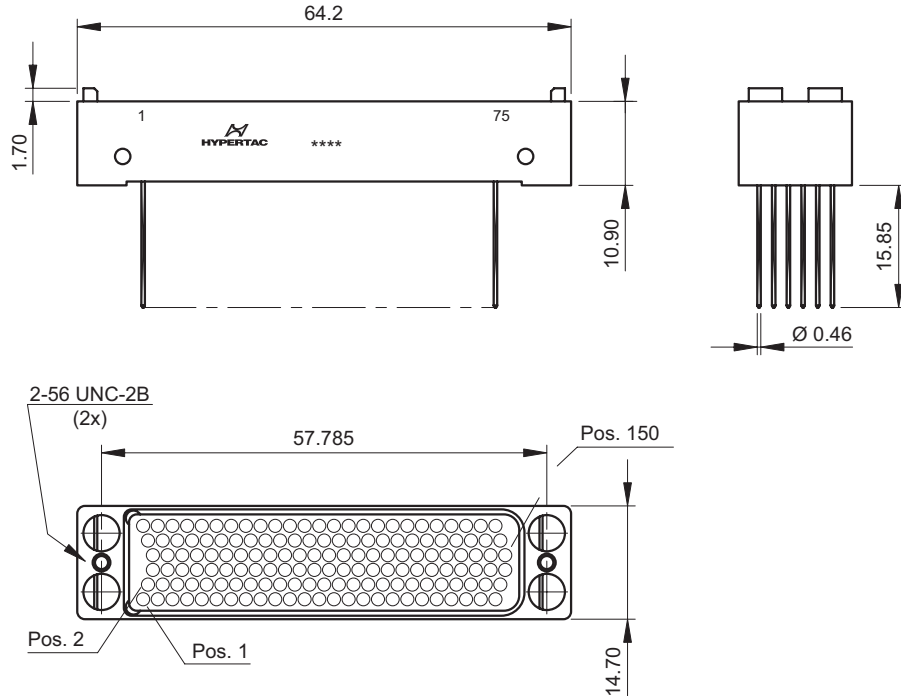

Ref. ord. C9394/17073

Panel cut-out

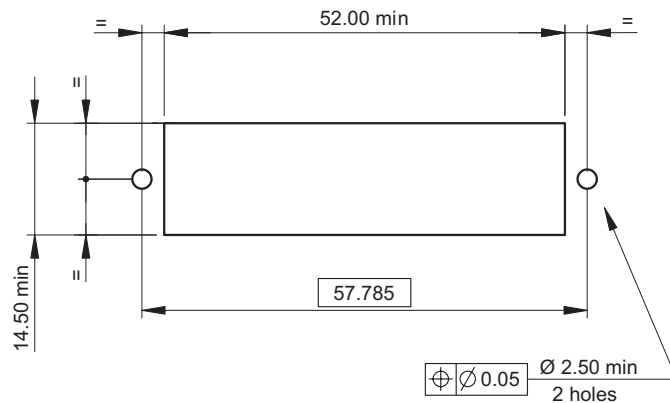

Plug connector, 300 contact positions, surface mount tail contact terminal style

Plug connector, 300 pin contacts, surface mount tail contact terminal style, board package thickness from 1.30 to 5.80

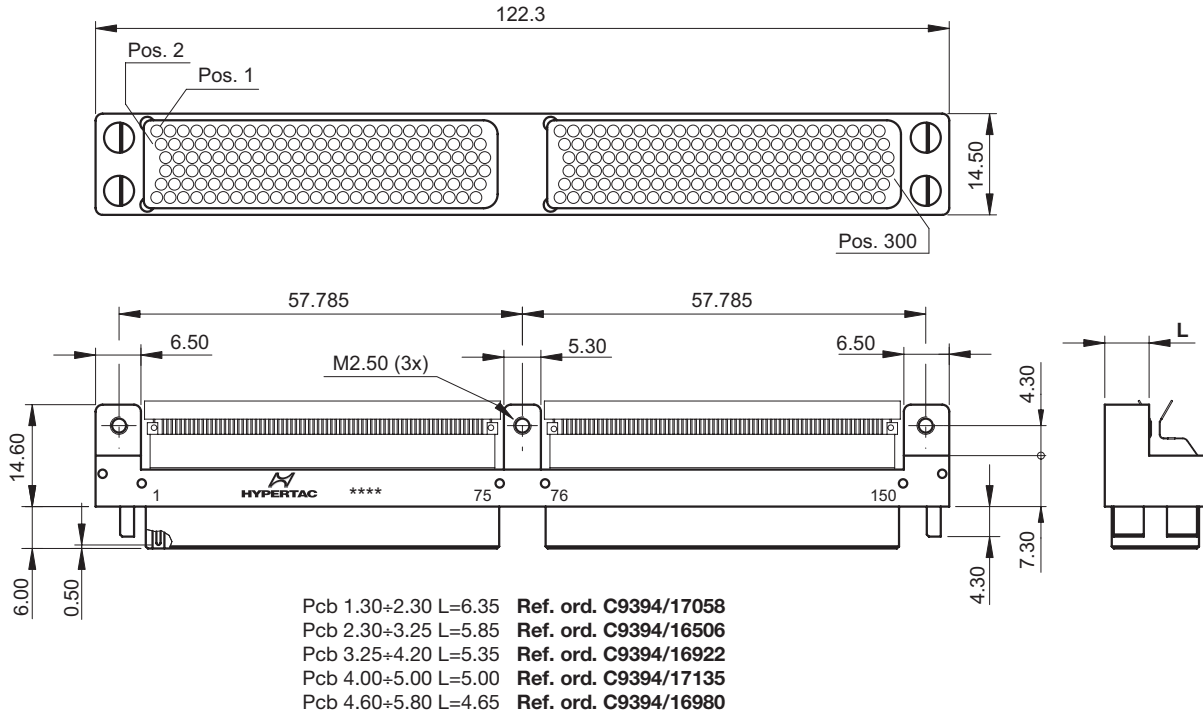

Mounting pattern, daughterboard application

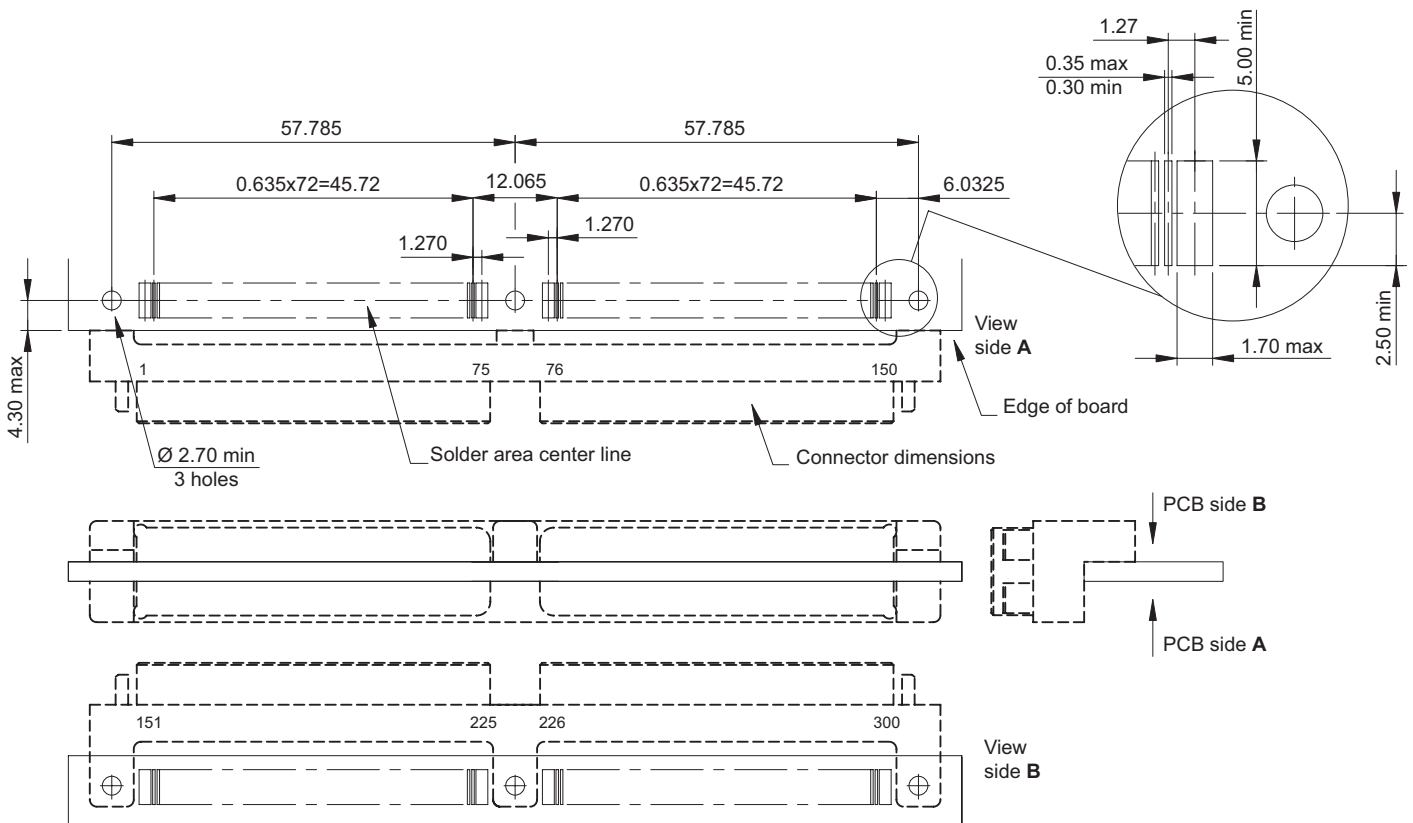

Receptacle connector, 300 contact positions, dip solder contact terminal style

Receptacle connector, 300 socket contacts, dip solder (straight) contact terminal style

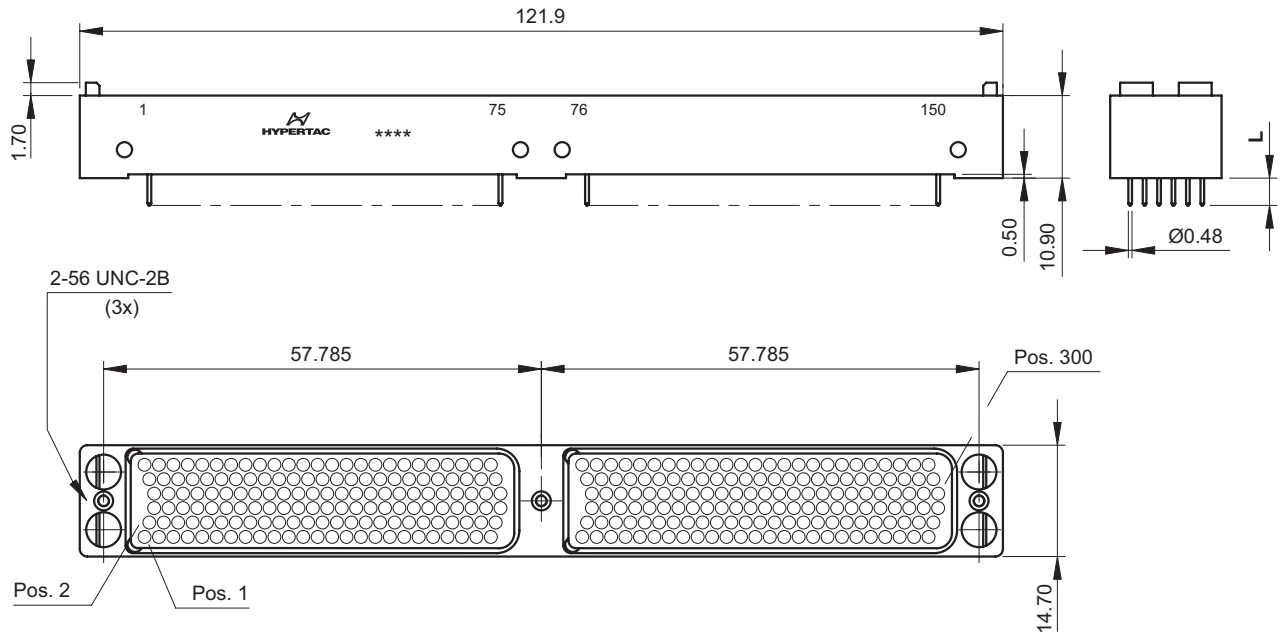

L=3.60 Ref. ord. C9394/16505
L=5.00 Ref. ord. C9394/16929

Mounting pattern, motherboard application

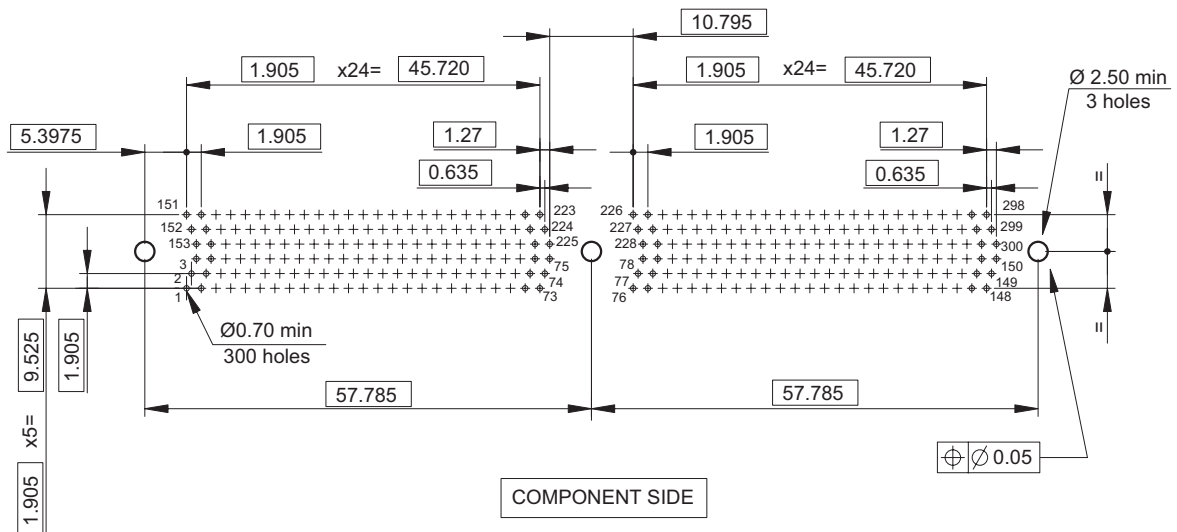

Receptacle connector, 300 contact positions, wire wrap post contact terminal style

Receptacle connector, 300 socket contacts, wire wrap post contact terminal style

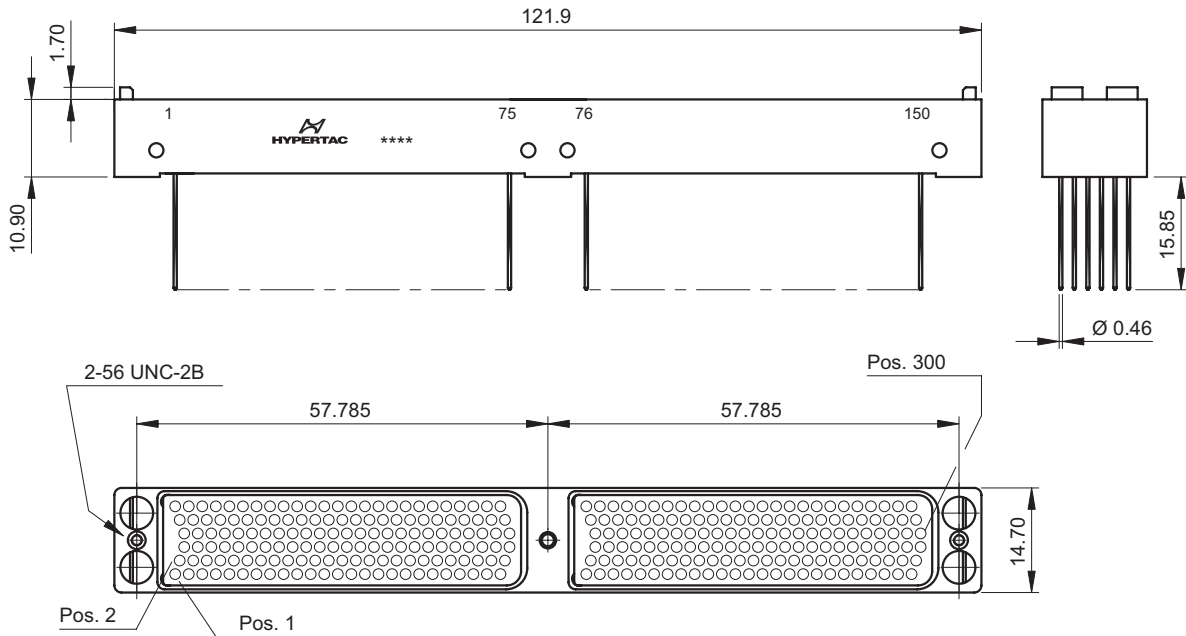

Ref. ord. C9394/16912

Panel cut-out

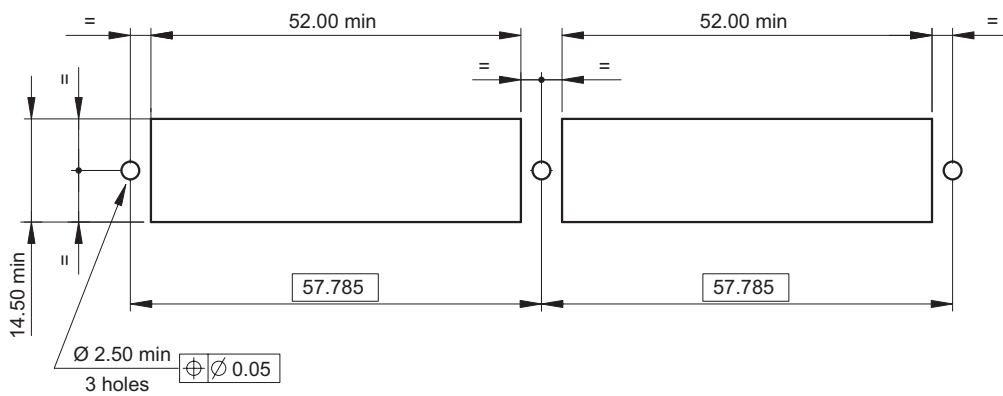

Plug connector, 450 contact positions, surface mount tail contact terminal style

Plug connector, 450 pin contacts, surface mount tail terminal style, board package thickness from 1.30 to 5.80

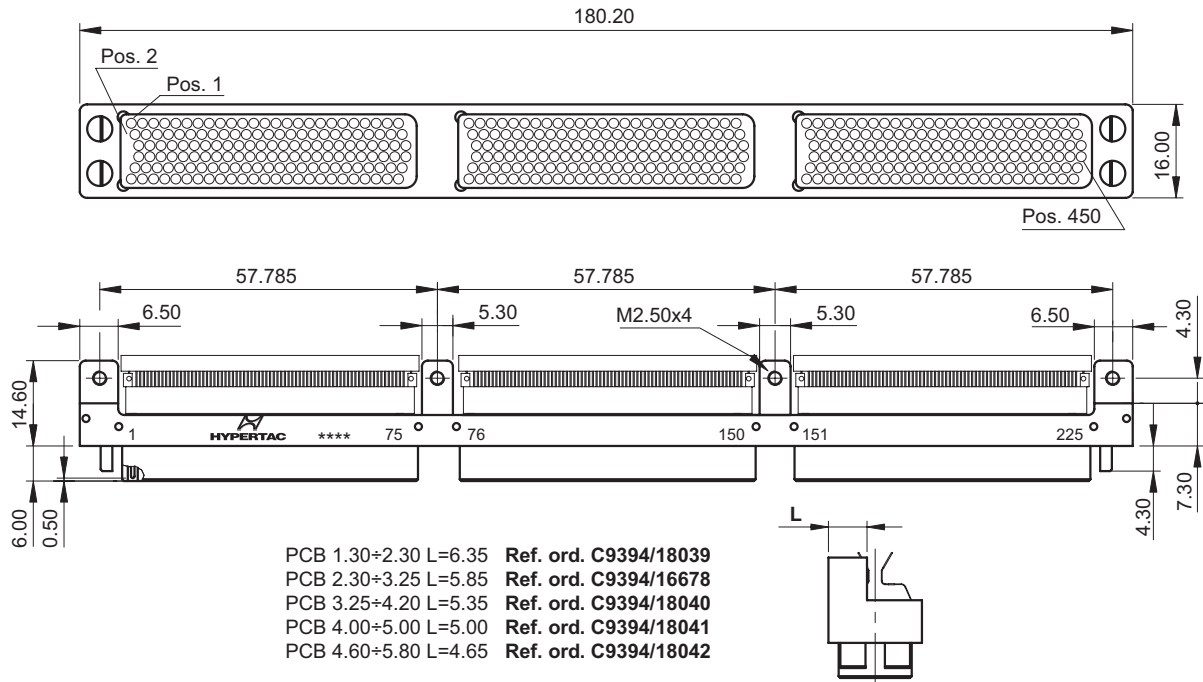

Mounting pattern, daughterboard application

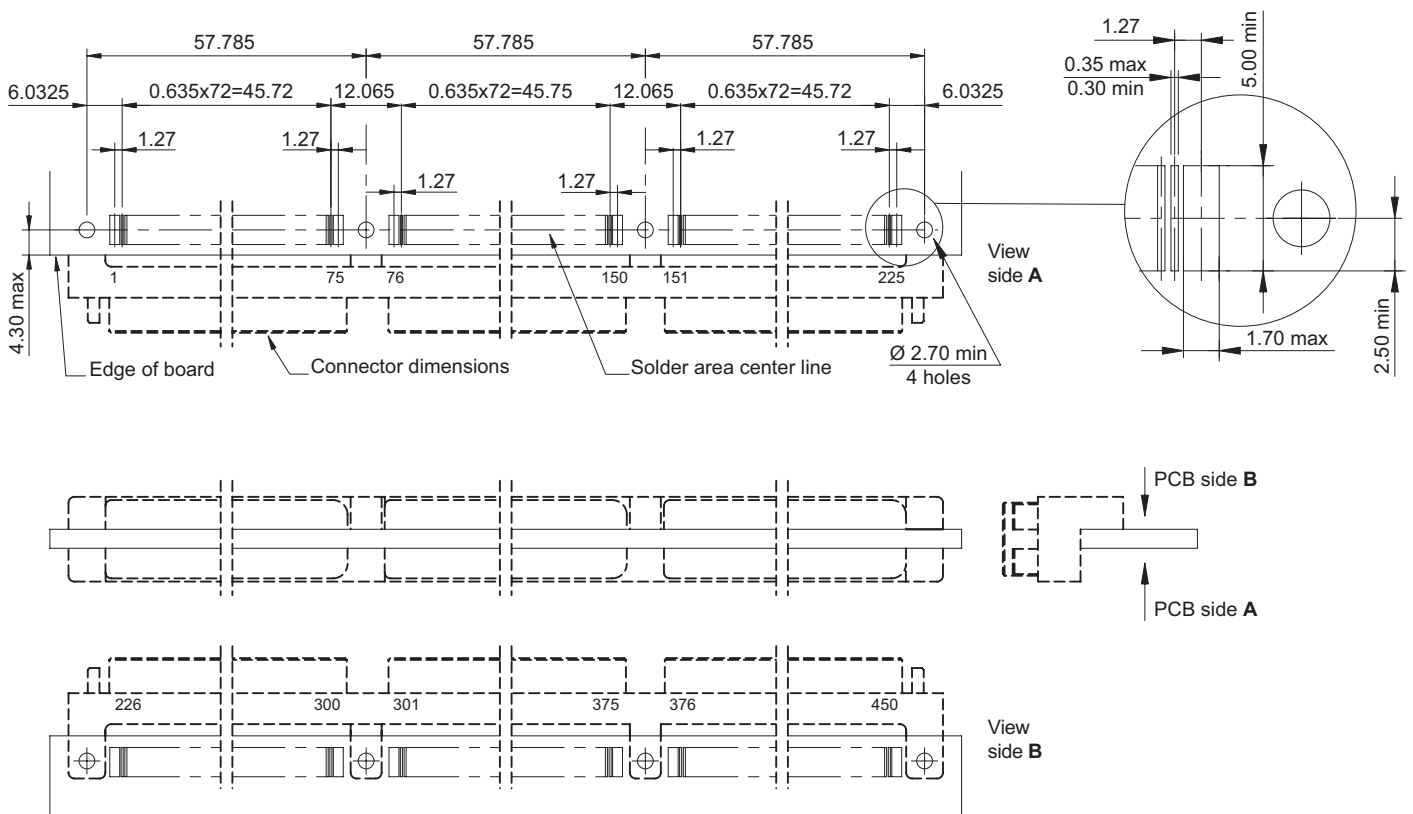

Receptacle connector, 450 contact positions, dip solder contact terminal style

Receptacle connector, 450 socket contacts, dip solder (straight) contact terminal style

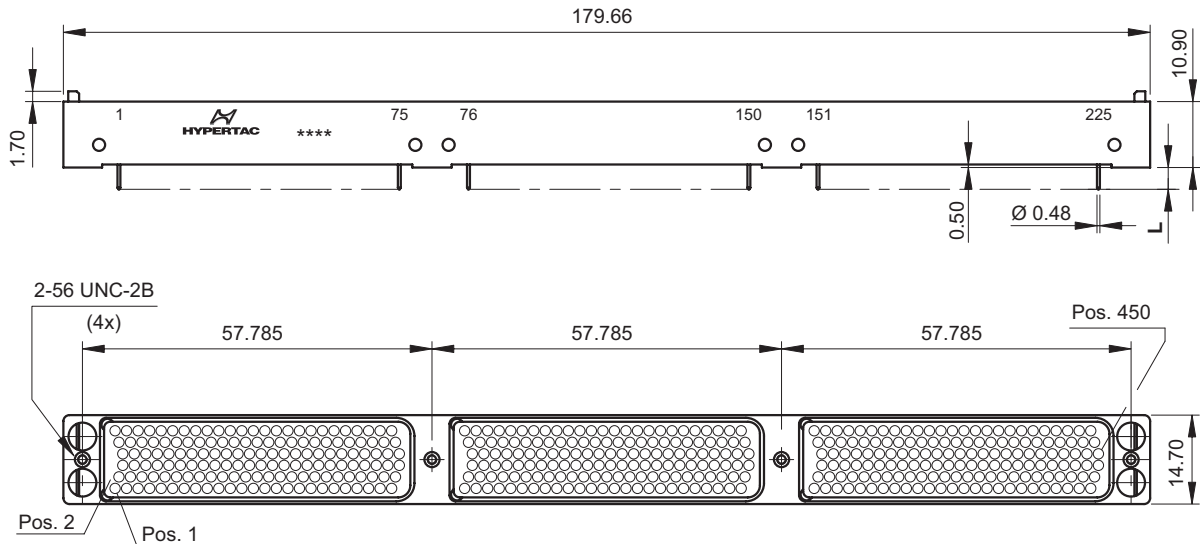

L=3.60 Ref. ord. C9394/16677
L=5.00 Ref. ord. C9394/17075

Mounting pattern, motherboard application

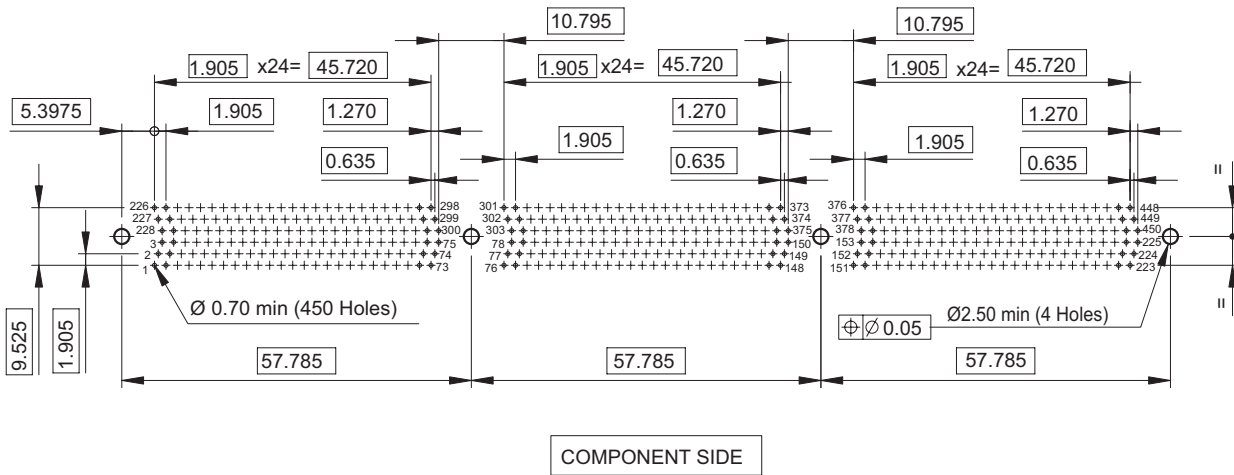

Receptacle connector, 450 contact positions, wire wrappost contact terminal style

Receptacle connector, 450 socket contacts, wire wrappost contact terminal style

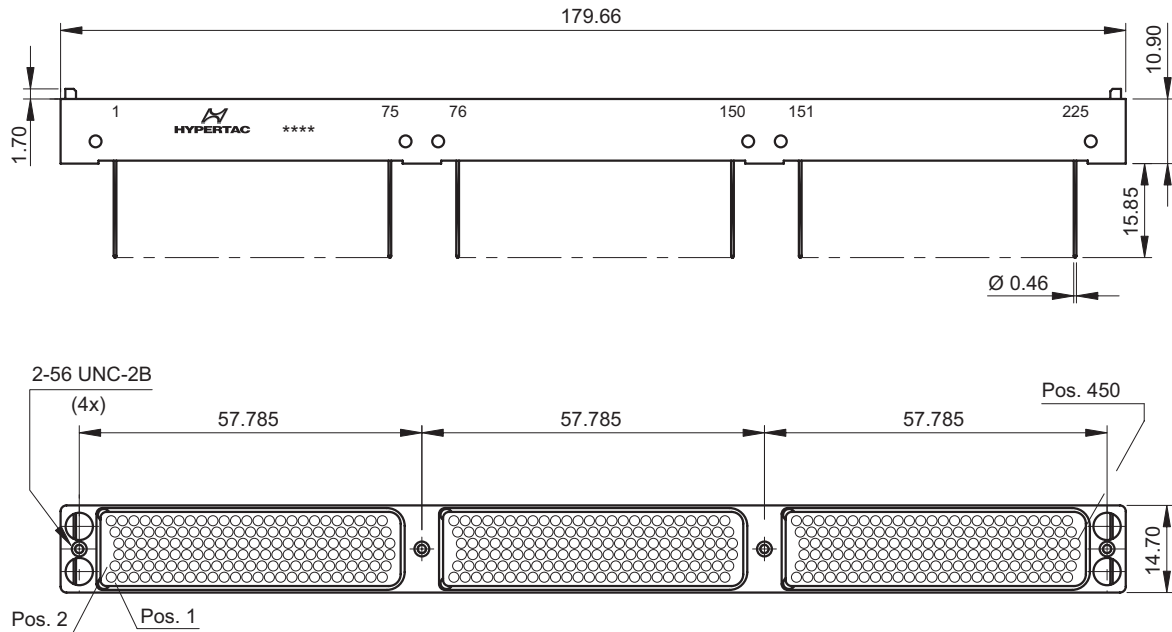

Ref. ord. C9394/17076

Panel cut-out

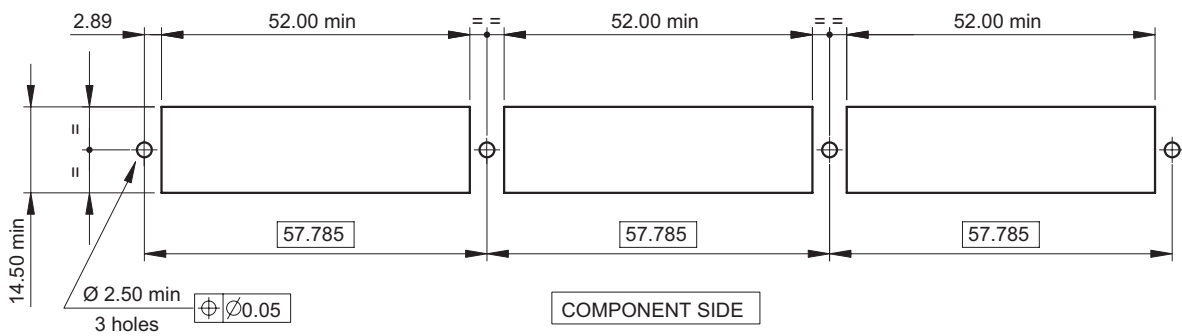

Extender board connectors

The following connectors are shipped without coding keys hardware

Receptacle connector, 150 socket contacts, surface mount tail terminal style, board package thickness from 1.30 to 5.80

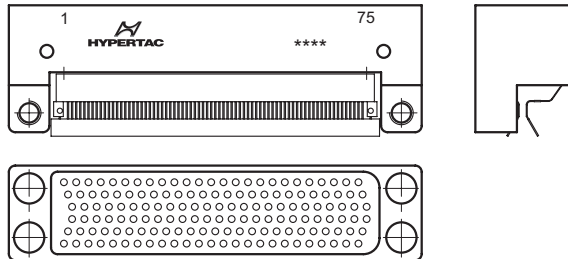

PCB thickness 1.30+2.30 L=6.45	Ref. ord. Ask Factory
PCB thickness 2.30+3.25 L=5.95	Ref. ord. Ask Factory
PCB thickness 3.25+4.20 L=5.45	Ref. ord. Ask Factory
PCB thickness 4.00+5.00 L=5.10	Ref. ord. Ask Factory
PCB thickness 4.60+5.80 L=4.75	Ref. ord. Ask Factory

Receptacle connector, 300 socket contacts, surface mount tail terminal style, board package thickness from 1.30 to 5.80

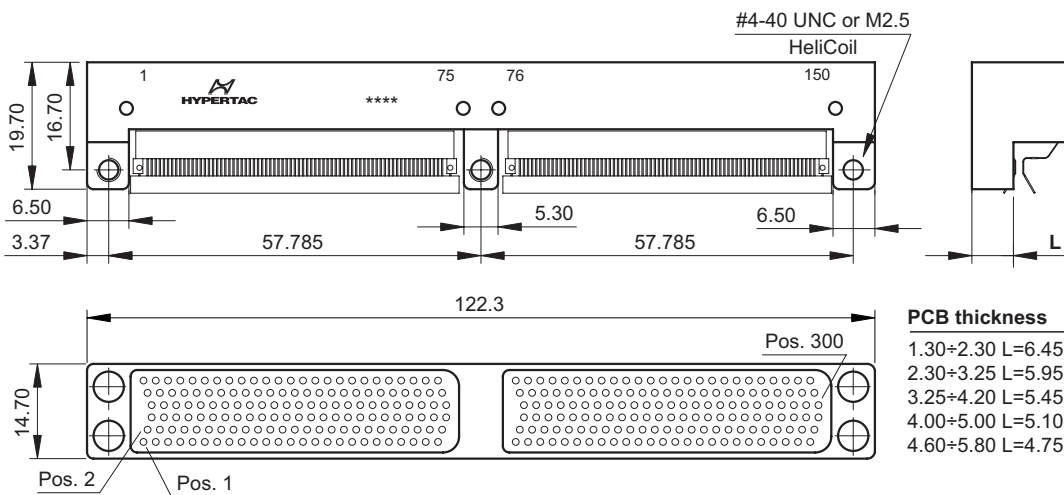

PCB thickness	Ref. ord. UNC	Ref. ord. M2.5
1.30+2.30 L=6.45	C9394/18510	C9394/18648
2.30+3.25 L=5.95	Ask Factory	C9394/18649
3.25+4.20 L=5.45	Ask Factory	C9394/18650
4.00+5.00 L=5.10	Ask Factory	Ask Factory
4.60+5.80 L=4.75	Ask Factory	Ask Factory

Receptacle connector, 450 socket contacts, surface mount tail terminal style, board package thickness from 1.30 to 5.80

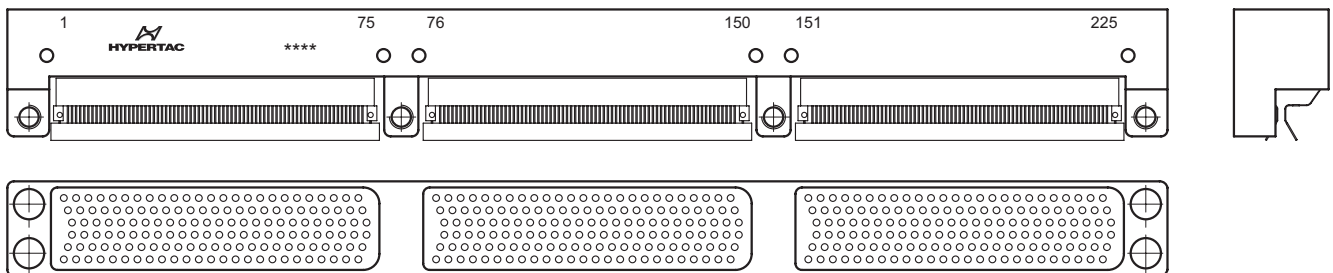

PCB thickness 1.30+2.30 L=6.45	Ref. ord. Ask Factory
PCB thickness 2.30+3.25 L=5.95	Ref. ord. Ask Factory
PCB thickness 3.25+4.20 L=5.45	Ref. ord. Ask Factory
PCB thickness 4.00+5.00 L=5.10	Ref. ord. Ask Factory
PCB thickness 4.60+5.80 L=4.75	Ref. ord. Ask Factory

Plug connectors, dip solder contact terminal style

Plug connector, 150 pin contacts, dip solder straight-thru

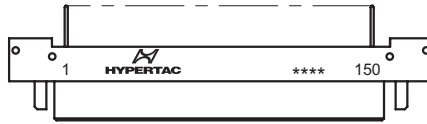
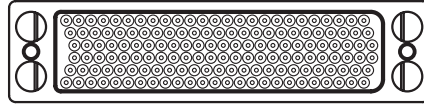

Ref. ord. Ask Factory

Plug connector, 300 pin contacts, dip solder straight-thru

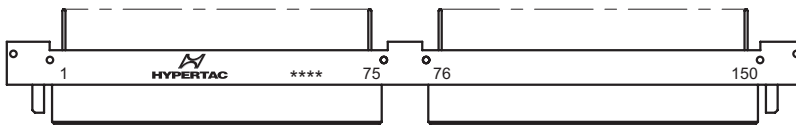
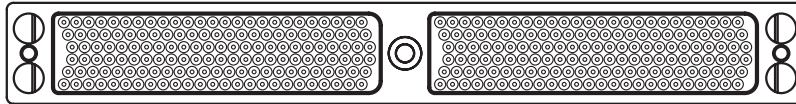

Ref. ord. Ask Factory

Plug connector, 450 pin contacts, dip solder straight-thru

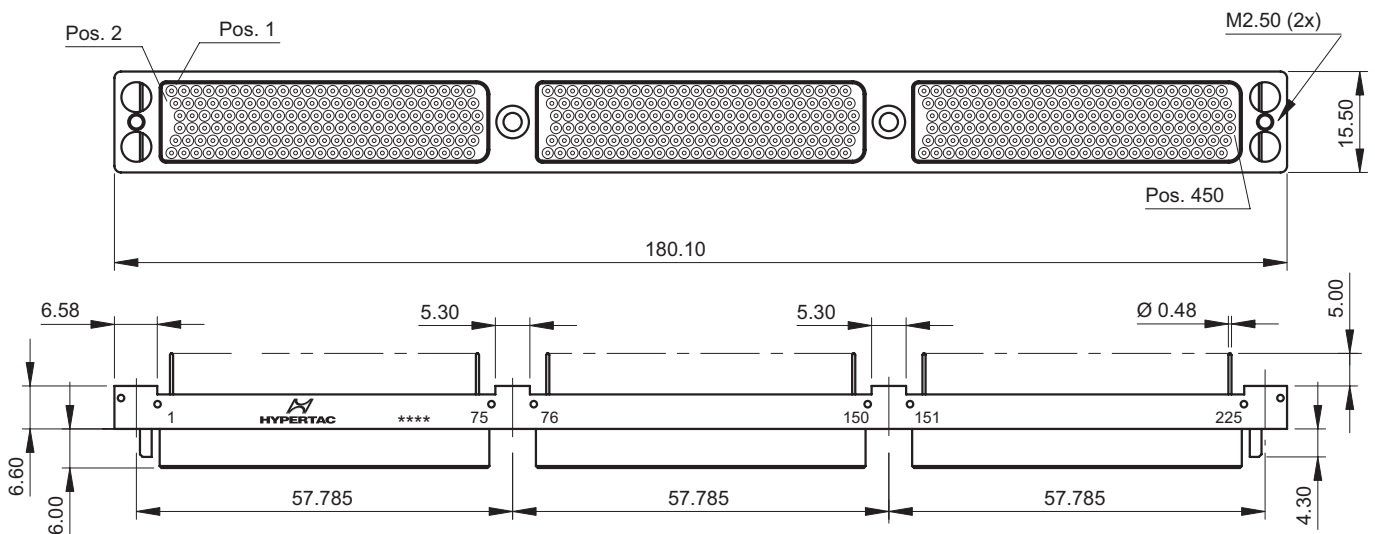

Ref. ord. 20925

Maximum Dimensions

Maximum dimensions of mated connectors

Maximum dimensions of mated connectors equipped with one only dielectric insert

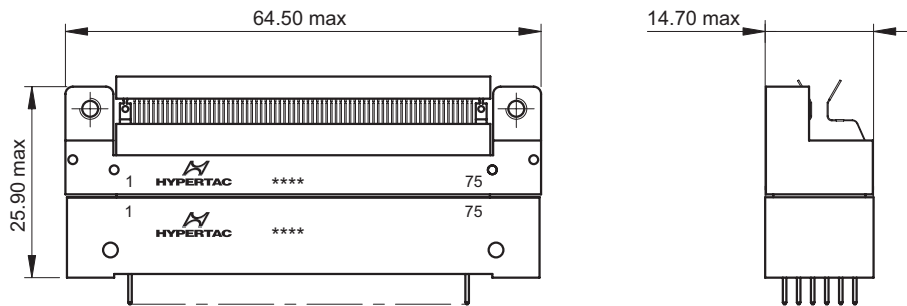

Maximum dimensions of mated connectors equipped with two dielectric inserts

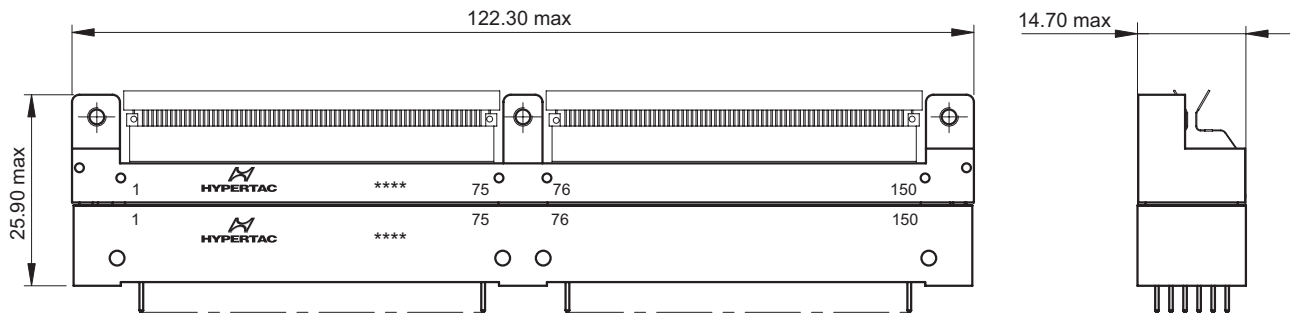

Maximum dimensions of mated connectors equipped with three dielectric inserts

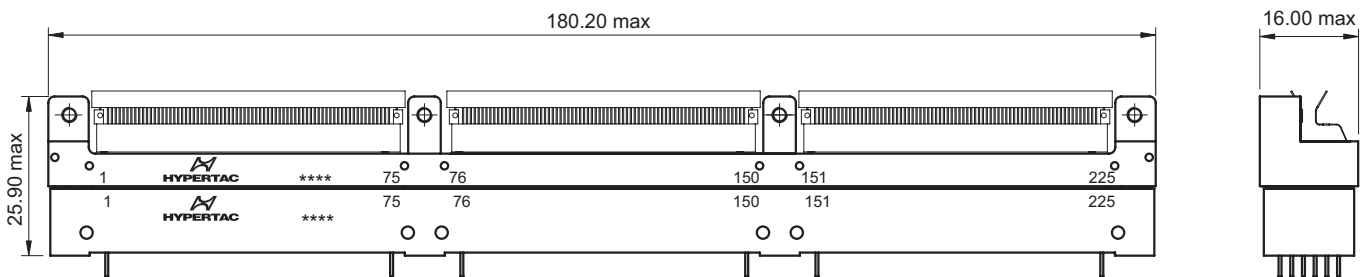

The Connector Halves Mating

Maximum permissible inclination, in longitudinal and in trasversal axis, of the connector halves, in order to ensure the acceptable electrical engagement made by all contacts.

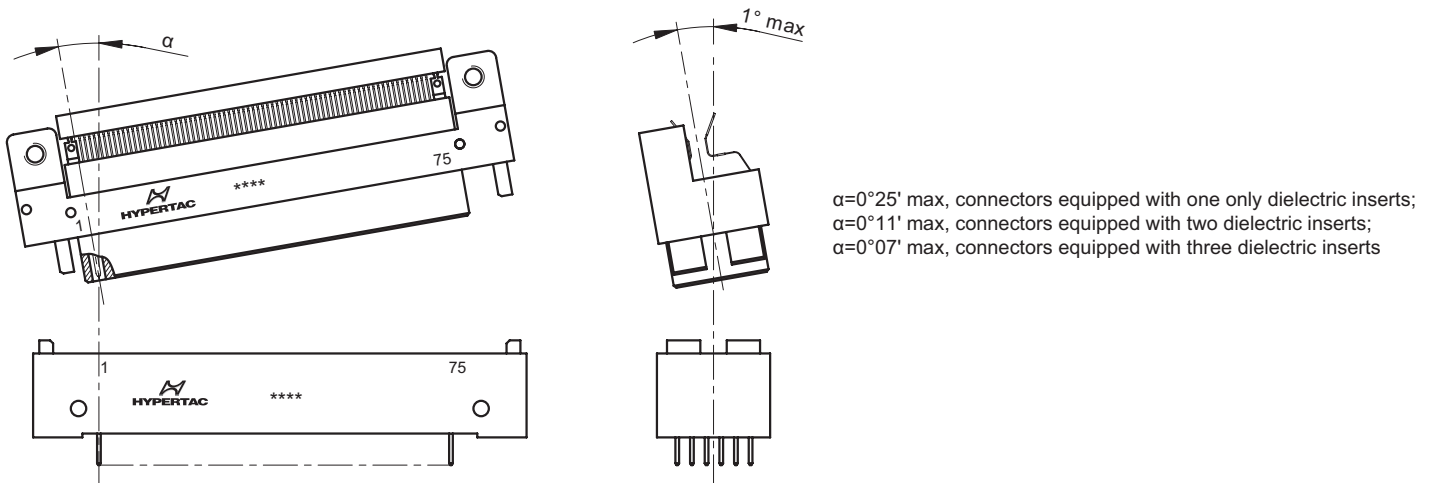

Maximum permissible displacement in order to ensure the suitable fully insertion of the connector halves

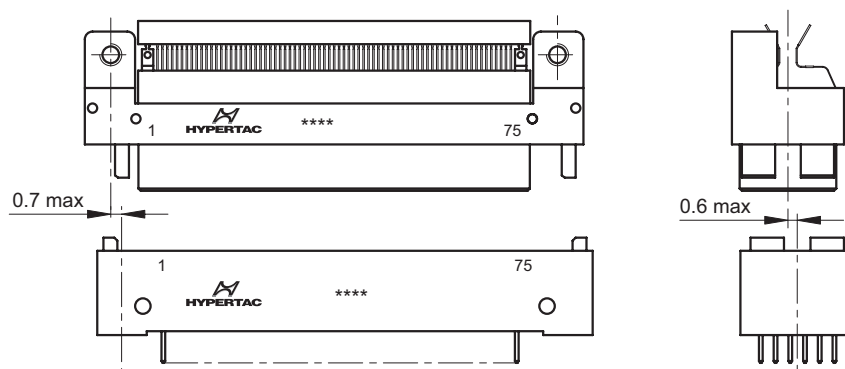

Maximum permissible distance of the connector halves in order to ensure the acceptable electrical engagement made by all contacts

Hardware Code Standard

Coding keys are supplied together the connector, but as unassembled kit consisting in 4 coding keys plus 1 coding key as spare part.

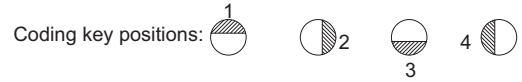
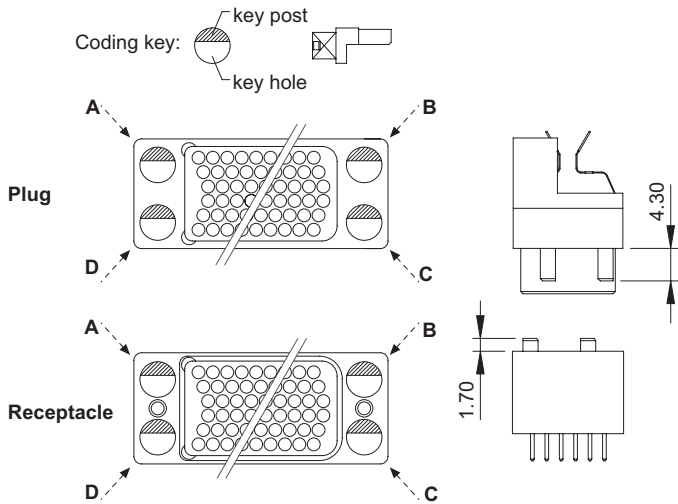

HARDWARE VARIATIONS

The guides and the screw locking are supplied mounted: please consult the factory for order p/n and extraction tool.

Connector supplied with two guide pins/sockets and two coding keys

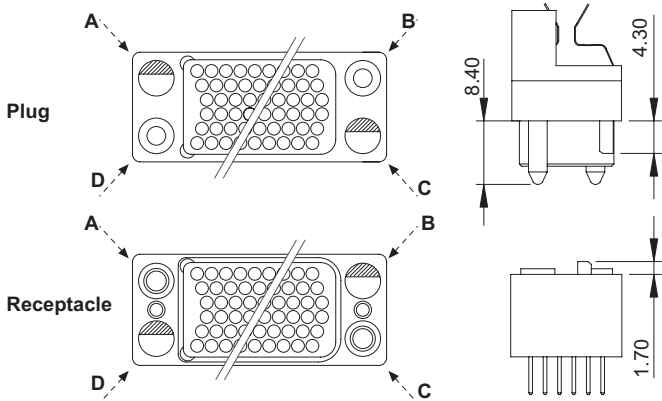

Plug connector				
No. polarization	A key	B key	C key	D key
00	Without coding keys			
01	1	1	1	1
02	1	1	2	2
03	1	1	3	3
04	1	1	4	4
05	1	2	1	2
06	1	2	2	1
07	1	3	1	3
08	1	3	3	1
09	1	4	1	4
10	1	4	4	1
11	2	1	1	2
12	2	1	2	1
13	2	2	1	1
14	2	2	2	2
15	2	2	3	3
16	2	2	4	4
17	2	3	2	3
18	2	3	3	2
19	2	4	2	4
20	2	4	4	2
21	3	1	1	3
22	3	1	3	1
23	3	2	2	3
24	3	2	3	2
25	3	3	1	1
26	3	3	2	2
27	3	3	3	3
28	3	3	4	4
29	3	4	3	4
30	3	4	4	3
31	4	1	1	4
32	4	1	4	1
33	4	2	2	4
34	4	2	4	2
35	4	3	3	4
36	4	3	4	3
37	4	4	1	1
38	4	4	2	2
39	4	4	3	3
40	4	4	4	4

Mates with

Receptacle connector				
No. polarization	A key	B key	C key	D key
00	Without coding keys			
01	1	1	1	1
02	4	4	1	1
03	3	3	1	1
04	2	2	1	1
05	4	1	4	1
06	1	4	4	1
07	3	1	3	1
08	1	3	3	1
09	2	1	2	1
10	1	2	2	1
11	4	1	1	4
12	1	4	1	4
13	1	1	4	4
14	4	4	4	4
15	3	3	4	4
16	2	2	4	4
17	3	4	3	4
18	4	3	3	4
19	2	4	2	4
20	4	2	2	4
21	3	1	1	3
22	1	3	1	3
23	3	4	4	3
24	4	3	4	3
25	1	1	3	3
26	4	4	3	3
27	3	3	3	3
28	2	2	3	3
29	2	3	2	3
30	3	2	2	3
31	2	1	1	2
32	1	2	1	2
33	2	4	4	2
34	4	2	4	2
35	2	3	3	2
36	3	2	3	2
37	1	1	2	2
38	4	4	2	2
39	3	3	2	2
40	2	2	2	2

Connector supplied with two guide pins/sockets and two screw locking (only connectors without backpanel)

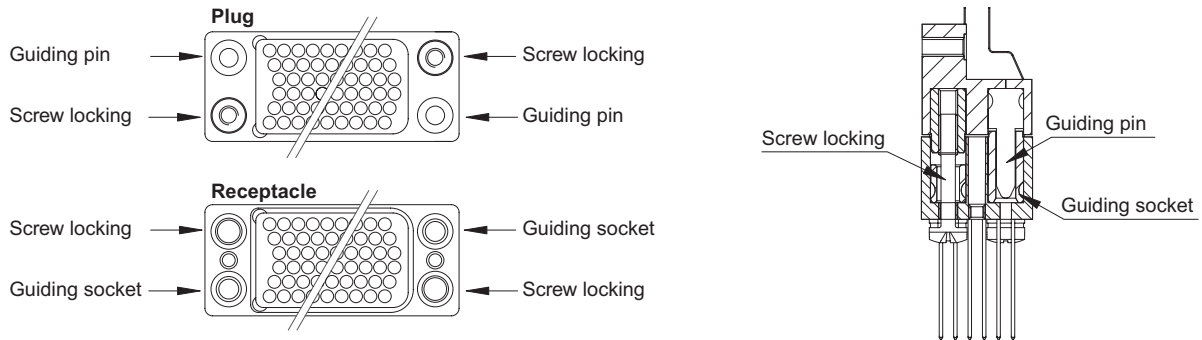

Connector supplied with two coding keys and two screw locking (only connectors without backpanel)

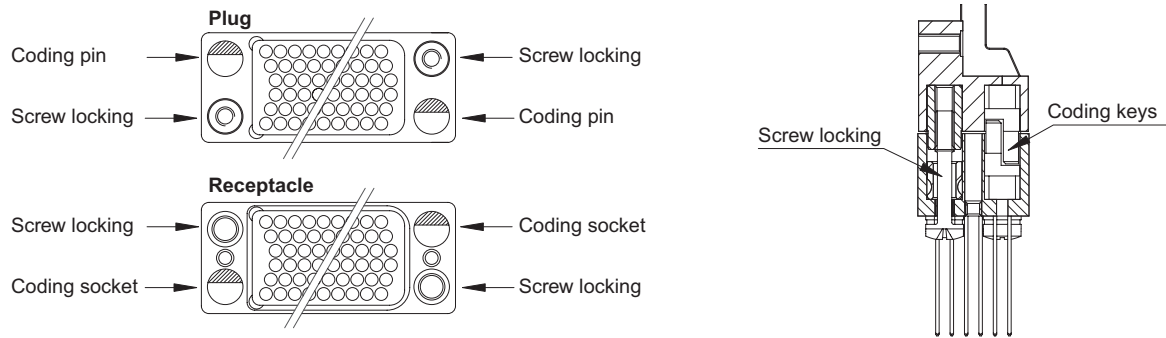

Note: the coding key is in thermoplastic polyester, the guide pin /socket and screw locking are in stainless steel.

C9394 Series Variation

1. Scope

1.1 Scope

This section covers C9394 metal shelled Connectors Family Variation, plug and receptacle style, 75 thru 225 pin or socket contact positions, proven to MIL-DTL-55302 performance standards. Contact arrangement is chevron pattern within each dielectric insert with three rows, .075 in (1.905 mm) center-to-center contact spacing in each row, and .075 in (1.905 mm) row-to-row spacing. Contact size is 0.6 mm nominal pin DIA. Polarization feature is incorporated in each connector assembly to assure correct insertion. Coding key system provides 16 possible keying combinations.

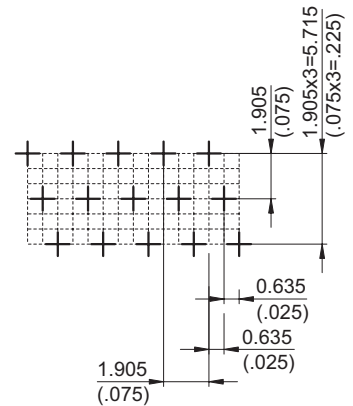

1.2 Contact terminal types

Plug connector, pin contacts equipped, is available assembled with flex-circuit conforming to MIL-P-50884 and its surface mount tails are the contact terminals for straddle mount, (daughterboard attachment). Receptacle connector, socket contacts equipped, is available with thru hole, as contact terminal for rigid PWB, (motherboard attachment).

2. Applied documents

2.1 Applied documents

C9394 Connectors Family is designed, manufactured, tested and delivered in accordance with the documents listed below. The latest issue and amendments in being on 30 June 1994 are used unless otherwise specified in this Design.

- MIL-C-26074 Coatings, electroless nickel requirement for.
- MIL-I-46058 Insulating compound, electrical (for coating printed circuit assemblies).
- MIL-P-50884 Printed-wiring, flexible and rigid-flex. sostituita da IPC-6013.
- MIL-DTL-55302 Connectors, printed circuit subassembly and accessories.
- MIL-I-81550 Insulating compound electrical, embedding, reversion resistant silicone.
- IPC-2223 Sectional design standard for flexible printed boards and IPC-2221 generic standard on printed board design.
- NASM21209 Insert, screw thread, coarse and fine, screw locking, helical coil, cres.

3. Requirements

3.1 Dielectric insert is an insulator body of molded one-piece construction.

3.1.1 Dielectric insert material is injection molded from glass reinforced polyphenylene sulfide (PPS) type GST-40F per MIL-M-24519 and in accordance with MIL-DTL-55302. This thermoplastic compound is flame resistant, having flammability rating V-O/5VA, without additives, per UL94.

3.2 Pin contact and contact termination

3.2.1 Pin contact and its surface mount tail termination are two-pieces construction type. These two-parts are assembled using a suitable tin-lead soldering.

Pin contact is screw machined from copper-alloy per ASTM-B-16 with protective finishing of gold plate, over suitable underplate, as specified in MIL-DTL-55302. The surface mount tail termination is the part of a proper flex-circuit conforming to MIL-P-50884 with tail finishing of tin-lead (50-70%) composition, .50 to .80 mil (12 to 20 micron) thick, per SAE AMSP81728 plating, tin-lead (electrodeposited)

3.2.1.1 Solder alloy composition.

Pin contact is soldered with flex-circuit, as its contact termination, using solder alloy composition Sn63 conforming to QQ-S-571. Soldered connections are coated using conformal coating per MIL-I-46058 per UR.

3.2.2 Pin contact terminal are screw machined, and one-piece construction, from copper-alloy per ASTM-B-16, with protective finishing of gold plate, over suitable underplate, as specified in MIL-DTL-55302.

3.3 Socket contact and contact termination

Socket contact is HYPERTAC, and contact terminal types are: dip solder, (straight)

3.3.1 Socket contact materials.

HYPERTAC springs are wire drawn from beryllium-copper alloy per ASTM-B-196. Socket contact body is screw machined from copper-alloy per ASTM-B-16. Protective finishing is gold plate, over suitable underplate, as specified in MIL-DTL-55302.

3.3.2 Dip solder, contact terminations are screw machined from suitable copper-alloys in accordance with MIL-DTL-55302, with protective finishing of gold plate, over suitable underplate, as specified in MIL-DTL-55302. Hot solder dipping, as dip solder termination end finishing, is available at Customer request.

3.4 Connector hardware standard consists of four coding keys (two supplied together plug connector and two together receptacle connector) in injection molded from thermoplastic polyester compound, 30% glass reinforced, in accordance with type GPT-30 of MIL-M-24519.

3.5 Plug and receptacle shells are machined from aluminium alloy per AMSQQA250/4 and finished with electroless nickel coating per MIL-C-26074.

3.5.1 Joining devices are corrosion-resistant steel per ASTM-A-693 and passivated per ASTM-A-967. Threaded insert, self-locking type, are conforming to MS21209.

3.6 Design and construction are in accordance with MIL-DTL-55302 requirements.

3.7 Requirements are:

- contact engagement and separation forces: maximum engagement force =70 g (2.47 oz); minimum separation force =7 g (.25 oz);
- connector mating and unmating forces: maximum mating force =60 g (1.76 oz) multiplied by number of contacts; minimum unmating force =15 g (.53 oz) multiplied by number of contacts;
- contact current rating: the connector may have any combination of current flow and ambient temperature provided the contact or connector temperature does not exceed 150 °C. The test current is 2.0 A for individually connected contact, and 1.0 A for series wired contacts; current rating of the contacts equipped with flex circuit termination shall be as per the requirements of MIL-P-50884 (MIL-STD-2118) for cross section 0.01 mm²;
- mated contact resistance: 10.0 mΩ maximum individual, if socket contacts have dip solder as contact termination;
- the flex-circuit resistance plus the soldering resistance, (namely surface mount tail terminal resistance), 30 mΩ maximum individual;
- the total resistance equals the surface mount tail terminal resistance plus the mated contact resistance;
- temperature range: normal operating temperature is between -65 °C and +150 °C;
- dielectric withstanding voltage: 1000 VRMS, 60 Hz at sea level, 250 VRMS, 60 Hz at 70,000 feet (21,336 m), when flex-circuit and its surface mount tails are conformally coated of a suitable electrical insulating compound as specified in MIL-I-46058;
- insulation resistance is ≥ 5000 MΩ at 500 VDC;
- contact life: 30,000 insertion and withdrawal cycles, with minimum wear;
- vibration: when tested in accordance with MIL-DTL-55302, and MIL-STD-1344 method 2005, 10-2000 Hz, 15 G peak, 4 h per axis, 100 mA, there are no interruption in continuity greater than 2 ns of the test circuit which incorporates mated contacts;
- shock: when tested in accordance with MIL-DTL-55302, and MIL-STD-1344 method 2004, 6 ms, 100 G sawtooth, six shocks, 100 mA, there are no interruption in continuity greater than 2 ns of the test circuit which incorporates mated contacts;
- solderability: in accordance with MIL-STD-202 method 208 at an uniform temperature of 245 °C for 5 s;
- resistance to soldering heat: in accordance with MIL-STD-202 method 210 condition C, 260 °C for 10 s;
- capacitance: contact to contact maximum 1.5 pF; contact to shell maximum 2.0pF;
- calculated inductance: maximum 15 nH.

4. Quality assurance provisions

This connectors are inspected using data values of Section 3 of this Design, and examinations and test methods in accordance with MIL-DTL-55302.

5. Packaging

5.1 Packaging requirements are in accordance with “Smiths Interconnect Packaging Procedures”, and then packaging is adequate to provide protection against any damage, breakage, or loss during shipment from the supply source to the ultimate using activity.

Hardware code standard

Coding keys are supplied together the connector, but as unassembled kit consisting in 2 coding keys plus 1 coding key as spare part.

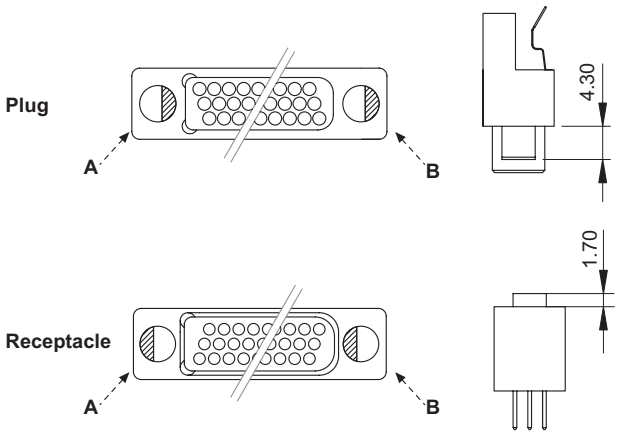
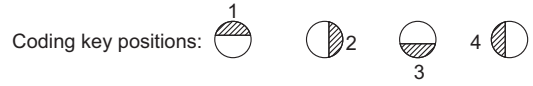
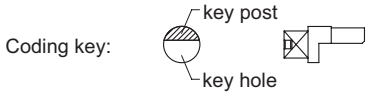

Plug connector		
No. polarization	A key	B key
00	Without coding keys	
01	1	1
02	1	2
03	1	3
04	1	4
05	2	1
06	2	2
07	2	3
08	2	4
09	3	1
10	3	2
11	3	3
12	3	4
13	4	1
14	4	2
15	4	3
16	4	4

Receptacle connector		
No. polarization	A key	B key
00	Without coding keys	
01	1	1
02	4	1
03	3	1
04	2	1
05	1	4
06	4	4
07	3	4
08	2	4
09	1	3
10	4	3
11	3	3
12	2	3
13	1	2
14	4	2
15	3	2
16	2	2

Mates with

Disclaimer 2017

All of the information included in this catalogue is believed to be accurate at the time of printing. It is recommended, however, that users should independently evaluate the suitability of each product for their intended application and be sure that each product is properly installed, used and maintained to achieve desired results.

Smiths Interconnect makes no warranties as to the accuracy or completeness of the information, and disclaims any liability regarding its use.

Smiths Interconnect reserves the right to modify design and specifications, in order to improve quality, keep pace with technological development or meet specific production requirements.

No reproduction or use without express permission of editorial and pictorial content, in any manner.

Product Portfolio

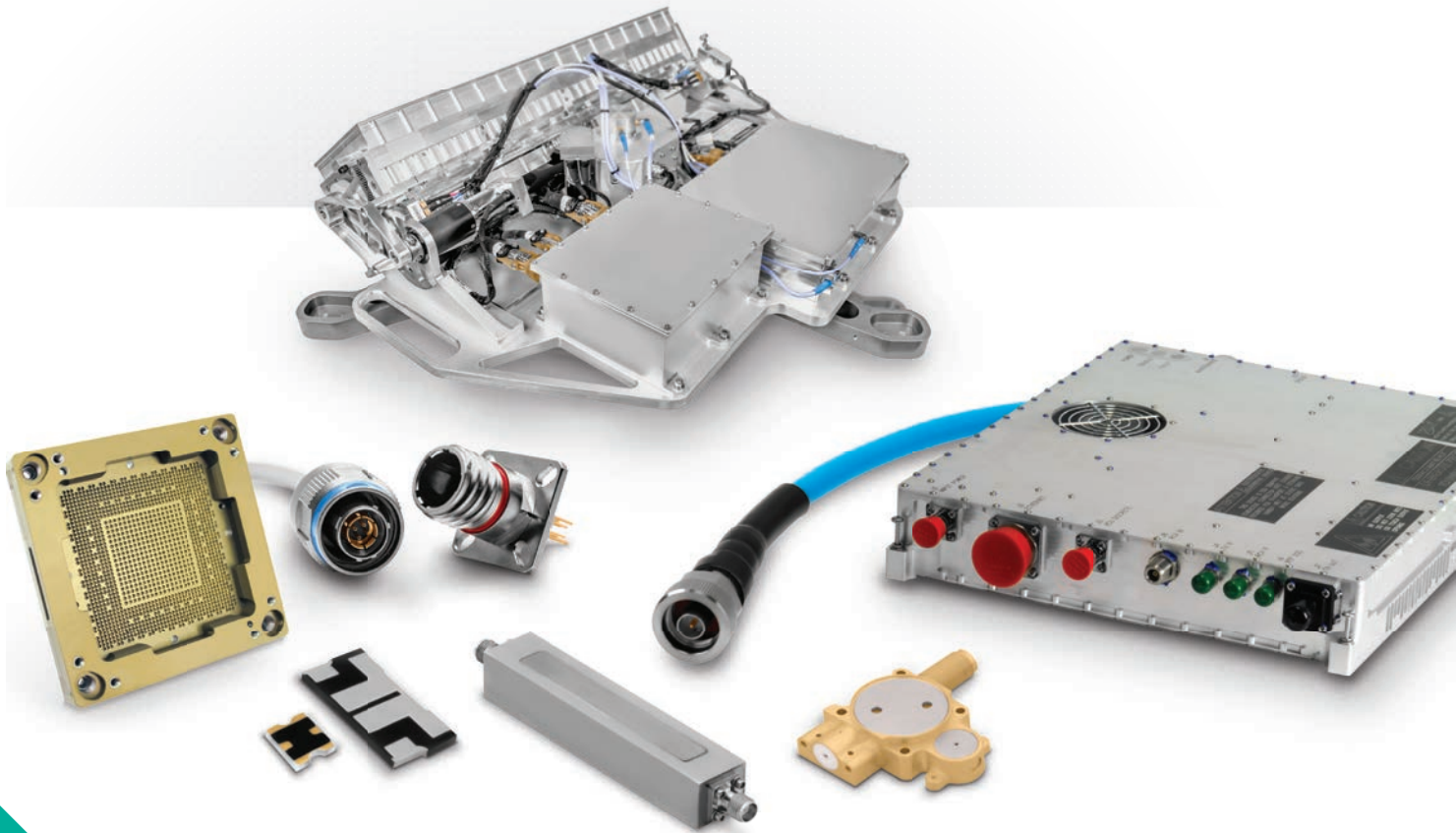

- Antenna Systems
- Cable Assemblies
- Connector Solutions
 - Ferrite Components & Assemblies
 - RF Filter Components & Assemblies
 - Integrated Microwave Assemblies
 - Millimeter-Wave Solutions
 - RF Components
 - Test Sockets and WLCSP Probe Heads
 - Time & Frequency Systems

Global Support

UK Headquarters

- London, UK
+44 20 7004 1600
info.uk@smithsinterconnect.com

US Headquarters

- Stuart, FL
+1 772 286 9300
info.us@smithsinterconnect.com

Americas

- Costa Mesa, CA
+1 714 371 1100
info.us@smithsinterconnect.com
- Milpitas, CA
+1 949 250 1244
info.us@smithsinterconnect.com
- Stuart, FL
+1 772 286 9300
info.us@smithsinterconnect.com
- Hudson, MA
+1 978 568 0451
info.us@smithsinterconnect.com
- Northampton, MA
+1 413 582 9620
info.northampton@smithsinterconnectinc.com
- Tampa, FL
+ 1 813 901 7200
info.tampa@smithsinterconnectinc.com
- Kansas City, KS
+1 913 342 5544
info.us@smithsinterconnect.com
- Salisbury, MD
+1 800 780 2169
info.us@smithsinterconnect.com
- Thousand Oaks, CA
+1 805 267 0100
info.thousandoaks@smithsinterconnectinc.com

Europe

- Deggendorf, Germany
+49 991 250 120
info.de@smithsinterconnect.com
- Genova, Italy
+39 0 10 60361
info.it@smithsinterconnect.com
- Dundee, UK
+44 1382 427 200
info.dundee@smithsinterconnect.com
- Rouen, France
+33 2 32 96 91 76
info.fr@smithsinterconnect.com
- Elstree, UK
+44 20 8236 2400
info.uk@smithsinterconnect.com

Asia

- Shanghai, China
+86 21 3318 4650
info.asia@smithsinterconnect.com
- Suzhou, China
+86 512 6273 1188
info.asia@smithsinterconnect.com
- Singapore
+65 6846 1655
info.asia@smithsinterconnect.com

more > smithsinterconnect.com | [in](#) [twitter](#) [G+](#) [YouTube](#)