

M-Series H-Pin Socket

Accelerated life testing solution

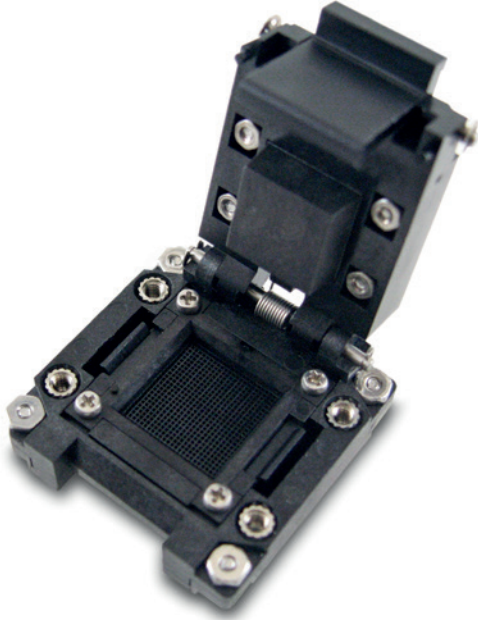

M-Series socket has long been the gold standard for reliability and out-of-the-box performance burn-in sockets. The high-quality components have been refined and enhanced over their lifetime for optimum performance and the highest quality.

M-Series being one of the most mature products in the portfolio does not mean it lacks technology. In fact, quite the opposite, the M-Series offers all the same configurable features and high-performance H-Pin™ contact technology to exceed performance expectations of the most demanding applications. The M-Series has been trusted to deliver uncompromised performance generation after generation.

The small outline footprint provides design flexibility and allows for high socket density on the burn-in board. a

Burn-in sockets using H-Pin technology for high-reliability testing of next-generation IC packages

Benefits

- Industry-proven design, in-house tooling, moulding, and machining, with 100% automated assembly.
- Extensive catalogue of components and configurable options
- Proven track record of reducing the cost of test leveraging modular components, automated assembly, and short lead times.
- Exceptional electrical performance provides wide RF bandwidth.

Feature Options

- Spring loaded plunger
- Heat sink
- HAST venting features
- Integrated thermal control with heater and sensor
- Reverse seating plane
- Max component clearance under the DUT
- 2 or 3 plate systems
- High temperature materials for above 200 °C applications

M-Series socket specifications

Mechanical properties

- Pitch: ≥ 0.30 mm
- Package size:
 - LGA: 0.6 mm to 16 mm
 - BGA: 0.6 mm to 16 mm
- Pin count: 1200+
- Temperature: -55°C to 260°C

Electrical properties

- Contact resistance: 35 m Ω
- Current carrying capacity: up to 4 A

Materials

- Contact: BeCu/Au plated
- Spring: SS/Au plated
- Socket: Engineering plastics

M-Series socket dimensions

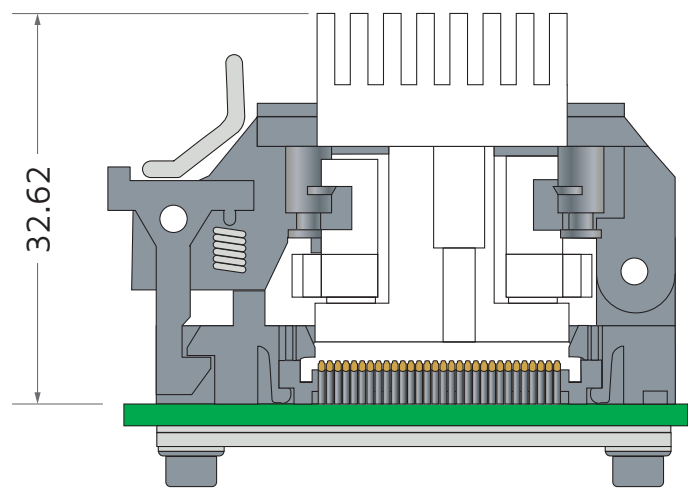
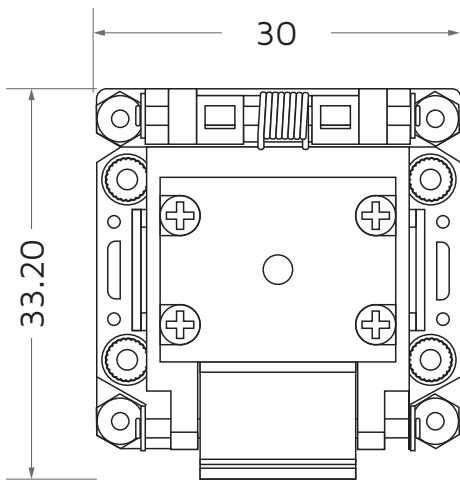

Dimensions are in mm.

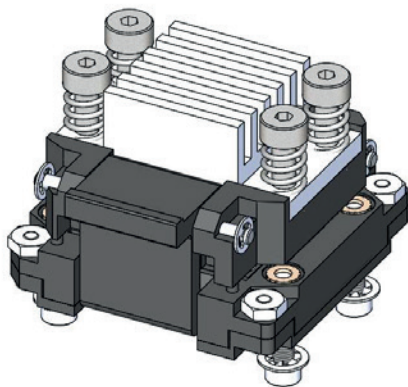

Heat sink, heater, and RTD

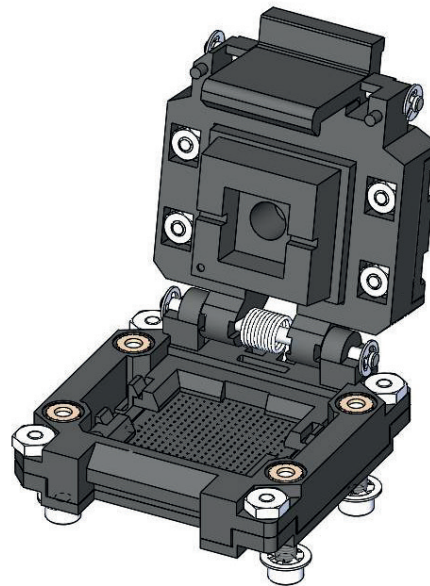

Spring-loaded plunger

more > smithsinterconnect.com | [in](#) [t](#) [v](#)