

HPD/HPF Series

High-Reliability Signal Connectors

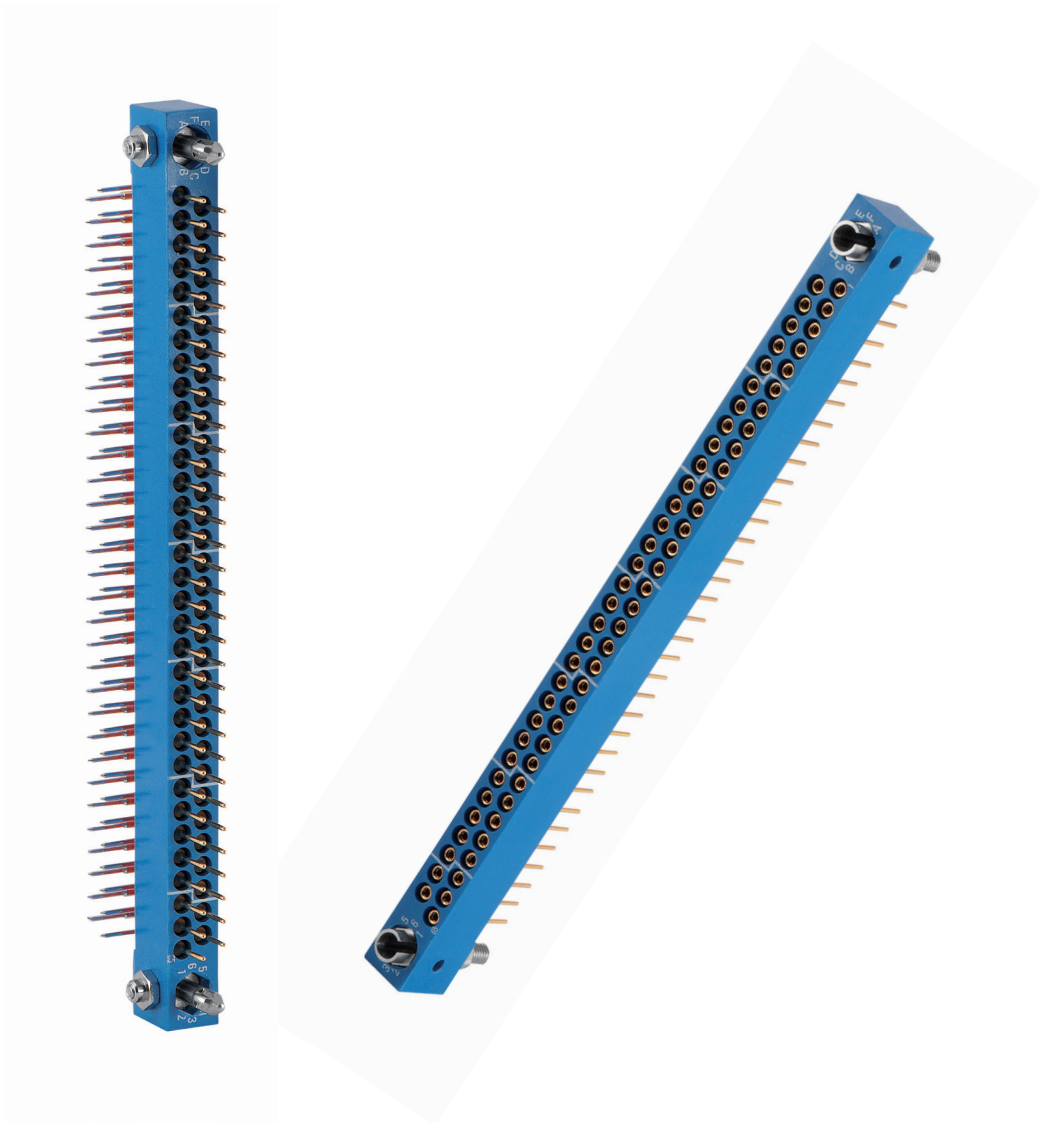

Hypertac® Hyperboloid Technology

Smiths Interconnect offers an extensive range of superior contact technologies suitable for standard and custom solutions. Hypertac® (HYPERboloid conTACT) is the original superior performing hyperboloid contact technology designed for use in all applications and in harsh and demanding environments where high reliability and safety are critical. The inherent electrical and mechanical characteristics of the Hypertac hyperboloid contact ensures unrivalled performance in terms of reliability, number of mating cycles, low contact force and minimal contact resistance. The shape of the contact sleeve is formed by hyperbolically arranged contact wires, which align themselves elastically as contact lines around the pin, providing a number of linear contact paths.

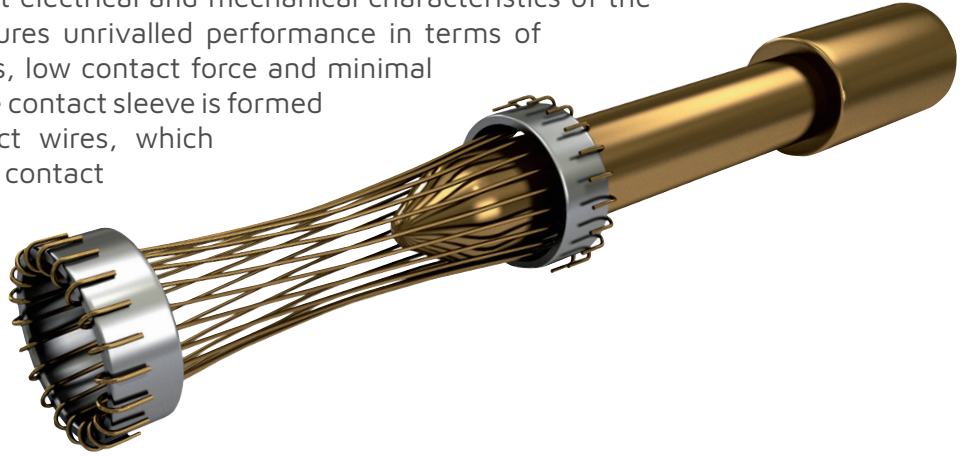

Features

Benefits

Low insertion/extraction forces

The angle of the socket wires allows tight control of the pin insertion and extraction forces. The spring wires are smoothly deflected to make line contact with the pin.

High density interconnect systems

Significant reductions in size and weight of sub-system designs. No additional hardware is required to overcome mating and unmating forces.

Long contact life

The smooth and light wiping action minimizes wear on the contact surfaces. Contacts perform up to 100,000 insertion/extraction cycles with minimal degradation in performance.

Low cost of ownership

The Hypertac contact technology will surpass most product requirements, thus eliminating the burden and cost of having to replace the connector or the entire subsystem.

Lower contact resistance

The design provides a far greater contact area and the wiping action of the wires insures a clean and polished contact surface. Our contact technology has about half the resistance of conventional contact designs.

Low power consumption

The lower contact resistance of our technology results in a lower voltage drop across the connector reducing the power consumption and heat generation within the system.

Higher current ratings

The design parameters of the contact (e.g., the number, diameter and angle of the wires) may be modified for any requirement. The number of wires can be increased so the contact area is distributed over a larger surface. Thus, the high current carried by each wire because of its intimate line contact, can be multiplied many times.

Maximum contact performance

The lower contact resistance of the Hypertac contact reduces heat build-up; therefore Hypertac contacts are able to handle far greater current in smaller contact assemblies without the detrimental effects of high temperature.

Immunity to shock & vibration

The low mass and resultant low inertia of the wires enable them to follow the most abrupt or extreme excursions of the pin without loss of contact. The contact area extends 360° around the pin and is uniform over its entire length. The 3 dimensional symmetry of the Hypertac contact design guarantees electrical continuity in all circumstances.

Reliability under harsh environments

Harsh environmental conditions require connectors that will sustain their electrical integrity even under the most demanding conditions such as shock and vibration. The Hypertac contact provides unmatched stability in demanding environments when failure is not an option.

Technical Characteristics

Contact number	17, 29, 33, 41, 48, 53, 62, 65, 72, 80, 84, 96, 98, 119, 120, 149, and 160
Contact diameter	0.60 mm
Current rating	4 A
Contact resistance	7 mΩ (max.)
Contact mating force	0.28 N (average)
Contact life cycle	>2,000
Breakdown voltage between contacts	1,920 VAC (min.) [sea level]
Dielectric withstanding voltage	1,400 VAC (min.) [sea level]
Temperature rating	-55 °C to 125 °C
Insulation resistance	5 GΩ @ 500 VDC (min.)
Insulator material	DAP

Contact

Material	Copper alloy
Plating (mating surfaces)	1.27 μm gold plate (min.)

Guide hardware

Material	Stainless steel BS 303
Plating	Passivated

The following unshrouded sizes comply to

MIL-C-55302/159 and 162	17, 29, 41, 53, and 65 position
MIL-C-55302/160 and 163	72, 84, 96, and 120 position
MIL-C-55302/161 and 164	160 position
BS 9525 N0001/1982	17, 29, 33, 41, 53, 65, 72, 84, 96, and 120 position
BS 9525 F0041/1989	17, 29, 33, 41, 53, 65, 72, 84, and 96 position Incorporates BS 9525 N0001 testing but includes Gunfire vibration test.
BS 9525 F0053/1995	Additional specification to BS 9525 N0001 with extra terminations.
BS 9525-F-0016/1995	48, 62, 80, 98, 119, 149, and 160 (Solid insulator) position

The following shrouded sizes are qualified to

BS 9525-F-0016/1995	48, 98, 119, and 160 position
---------------------	-------------------------------

HPD/HPF Connectors Summary

Number of Positions	Overall Length (mm)	Contact Rating at s.t.p. (A)	Number of Contact Rows	Contact Pitch (mm)	Contact Pin Diameter (mm)	Connector Prefix	Shrouded/Unshrouded
17	38.50	4.0	2	2.54	0.6	HPD	Unshrouded
29	53.70	4.0	2	2.54	0.6	HPD	Unshrouded
33	58.80	4.0	2	2.54	0.6	HPD	Unshrouded
41	69.00	4.0	2	2.54	0.6	HPD	Unshrouded
48	58.30	4.0	3	2.54	0.6	HPF	Unshrouded
48	61.00	4.0	3	2.54	0.6	HPM	Shrouded
53	84.20	4.0	2	2.54	0.6	HPD	Unshrouded
62	69.00	4.0	3	2.54	0.6	HPF	Unshrouded
65	99.50	4.0	3	2.54	0.6	HPD	Unshrouded
65	103.12	4.0	2	2.54	0.6	HPP	Shrouded
72	114.70	4.0	2	2.54	0.6	HPD	Unshrouded
80	84.20	4.0	3	2.54	0.6	HPF	Unshrouded
84	129.60	4.0	2	2.54	0.6	HPD	Unshrouded
96	145.20	4.0	2	2.54	0.6	HPD	Unshrouded
98	99.50	4.0	3	2.54	0.6	HPF	Unshrouded
119	117.26	4.0	3	2.54	0.6	HPF	Unshrouded
120	175.50	4.0	2	2.54	0.6	HPD	Unshrouded
149	142.55	4.0	3	2.54	0.6	HPF	Unshrouded
160	158.00	4.0	3	2.54	0.6	HPF	Unshrouded
160	161.30	4.0	3	2.54	0.6	HPM	Shrouded

HPD connectors summary

HPD/HPF Connectors Series offer a wide range of termination and guide styles. A 'Preferred Options' list, as illustrated below, has been prepared. These offers utilise the more common piece parts and selections have been made from across the range. To benefit from standard price/lead time reductions a connector must be assembled from parts within the Preferred Listings.

Termination styles - preferred options

A wide range of Termination Styles is available, please see page 4 and 19.

Please enquire with our Sales Office for additional details on Termination Styles

Termination type	Part no.	Description
B	HPD-488-7 male 1st row	Through board solder-90°
B	HPD-489-7 male 2nd row	Through board solder-90°
B	HPD-462-7 male 3rd row	Through board solder-90°
B	HPD-596-9 female 1st row	Through board solder-90°
B	HPD-598-9 female 2nd row	Through board solder-90°
B	HPD-599-9 female 3rd row	Through board solder-90°
C	HPD-486-7 male	Crimp
C	HPD-526-9 female	Crimp
L	HPD-685-7 male 1st row	Through board solder-90°
L	HPD-688-7 male 2nd row	Through board solder-90°
L	HPD-691-7 male 3rd row	Through board solder-90°
L	HPD-708-9 female 1st row	Through board solder-90°
L	HPD-712-9 female 2nd row	Through board solder-90°
L	HPD-716-9 female 3rd row	Through board solder-90°
P	HPD-487-7 male	Through board solder-straight
P	HPD-522-9 female	Through board solder-straight

Guide styles - preferred options

A wide range of Guide Styles is available.

Please enquire with our Sales Office for additional details

Style	Style	Style	Style	Style	Style
AO (see page 27)	HO (see page 27)	LB*	NO (see page 24)	RO (see page 25)	ZO*
BO (see page 28)	JO (see page 27)	LO*	PO (see page 25)	UO (see page 26)	
EO*	KB (see page 26)	LV*	QO (see page 27)	VO (see page 27)	
GO*	KO (see page 26)	NC (see page 24)	RA (see page 25)	VL*	

* Please enquire with our Sale Offices for further details on the above guide styles

Plating finish

U-Gold plate (ASTM-B-488)

How to order

Solid Insulators

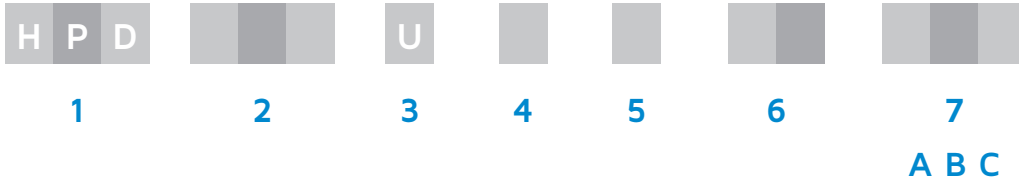

1 Connector family												
2 Number of cavities	D	017	029	033	041	053	065	072	084	096	120**	
	P	065										
	F	048	062	080	098	119	149	160				
	M	048	098**	119**	160							
3 Contact plating	U	Gold plate (ASTM-B-488)										
4 Contact gender	M	Male	F	Female	O	Contacts not supplied			C	Pin carrier HPD and HPF only		
5 Contact terminations	A	B	C	D	F	L	M	P	Q	R		
	S	X		O	Contacts not supplied							
(See 'HPD contact termination and codes' for details)												
6 Guide styles	See 'HPD guide style index' and 'HPD guide styles' for details or										OO	Guides not supplied
7 Variation codes	A	O	No variation				3	Centre guide polarised				
		D	Outer 2 of 3 rows loaded				Q	Centre row of 3 rows loaded				
	B Printing	O	Reverse (BS spec. standard)				2	Standard (BS spec. standard)				
		(See 'HPD insulators' for details)										
	C	O	No variation				B	90° termination tinned and potted				
		C	90° termination potted				X	Termination tinned				

* Off the shelf

** Made to order

How to order

Two-part Insulators

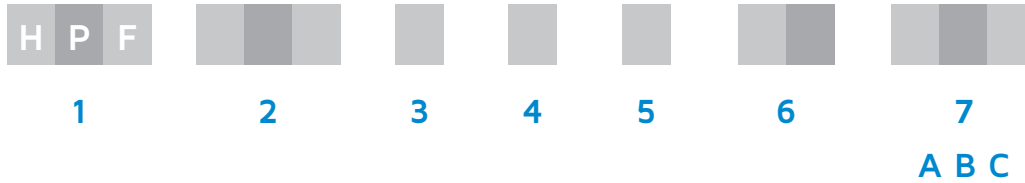

1 Connector family			
2 Number of cavities	098	160	
3 Contact plating	A Gold plate	U Gold plate (ASTM-B-488)	
4 Contact gender	F Female		
5 Contact terminations	6	7	
	8	(See 'HPD contact termination and codes' for details)	
6 Guide styles	L 1 L 2 L 5 5 G 5 L 5 M 5 N		
	See 'HPD guide style index' and 'HPD guide styles' for details)		
7 Variation codes	A	0 No variation	3 Centre guide polarised
		D Outer 2 of 3 rows loaded	Q Centre row of 3 rows loaded
	B Printing	0 Reverse (BS spec. standard)	2 Standard (BS spec. standard)
		5 Reverse (MIL spec. standard)	7 Standard (MIL spec. standard)
	C	2 Two-part Insulator	

How to order

If additional guides are required

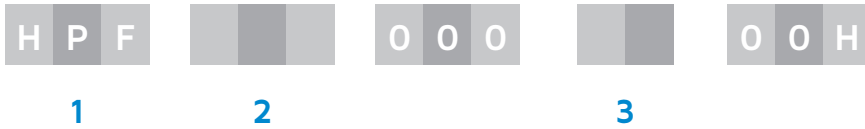

1 Connector family	D HPD	F HPF
2 Guides	065 Set of two HPD Guides	072 Set of three HPD Guides
	149 Set of two HPF Guides	160 Set of three HPF Guides
3 Guide styles	See 'HPD guide style index' and 'HPD guide styles' for details	

Example Guide Styles KS (male polarised) is required	
HPD06500KS00H	Two (HPD KS) guides
HPD072000KS00H	Two (HPD KS) guides + one (HPD AS) unpolarised guide
HPF149000KS00H	Two (HPF KS) guides
HPF160000KS00H	Two (HPF KS) guides + one (HPF AS) unpolarised guide

Insulators

Two row - style HPD

17 to 65 position unshrouded

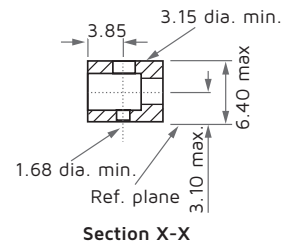
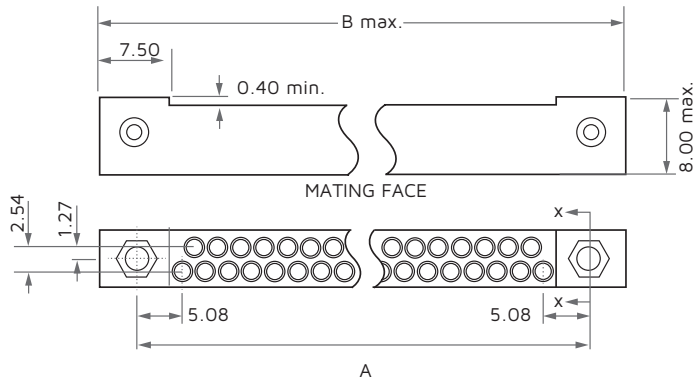

Two row - style HPP

65 position shrouded (fitted with male contacts only)

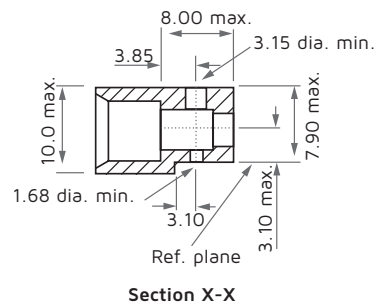
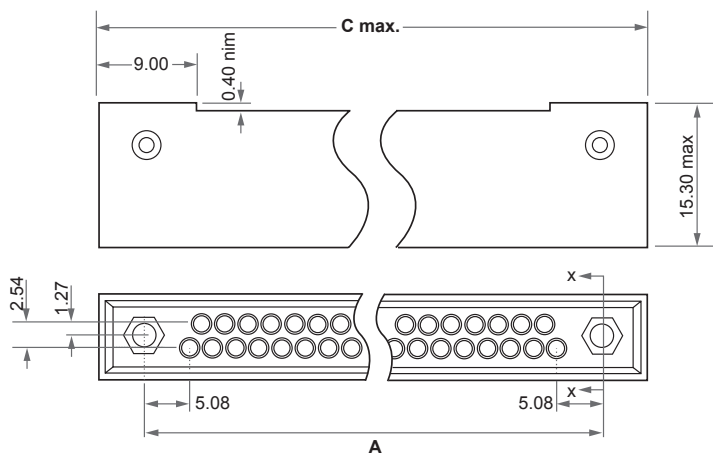

No. of positions	65
Dimension A	91.44
Dimension B	99.50
Dimension C	103.42

All diagrams are shown in 3rd angle projection with dimensions in millimetres

Insulators

Two row - style HPD

72 to 120 position unshrouded

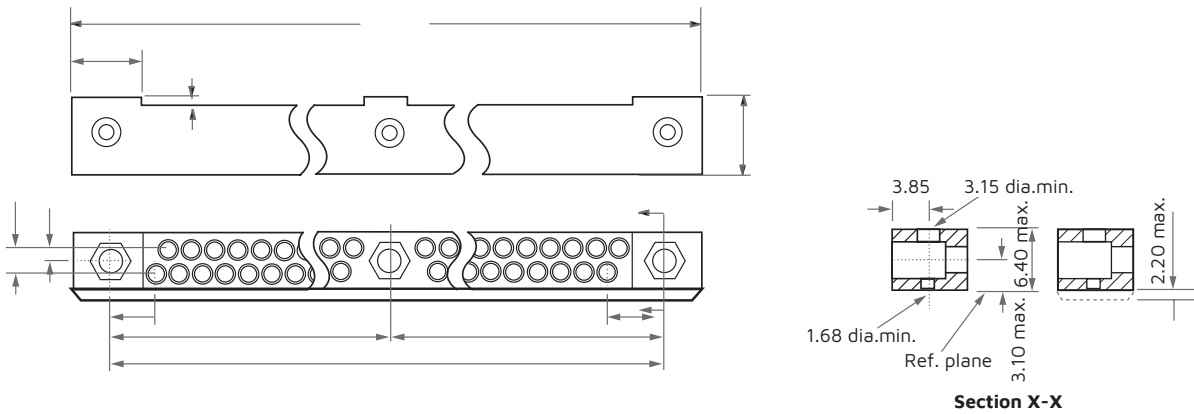

Thicker insulators are available for 84 and 96 positions for vertical applications only.

They cannot be used in conjunction with shrouded insulators.

All diagrams are shown in 3rd angle projection with dimensions in millimetres

Insulators

Three row - style HPF

62 to 80 position unshrouded

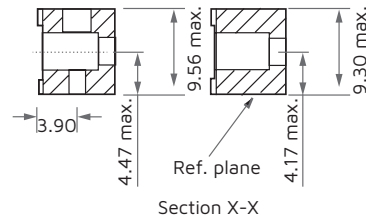
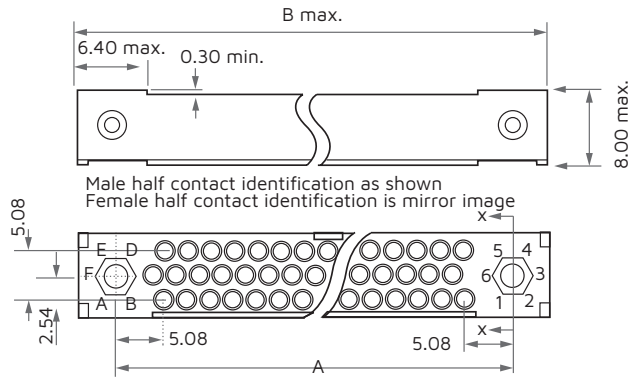

Male half use with transverse or vertical mount hardware.
 Female half use with transverse or vertical mount hardware.

Three row - style HPF

98 to 149 position unshrouded

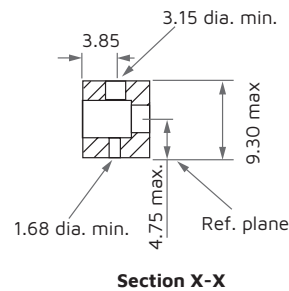
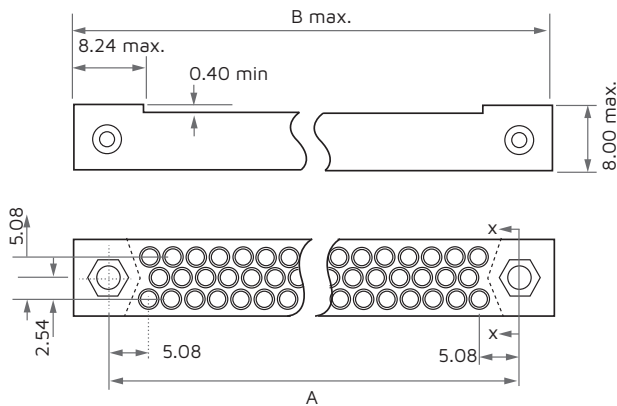

No. of positions	62	80	98	119	149
Dimension A	60.96	76.20	91.44	109.22	134.62
Dimension B	68.90	84.10	99.50	117.26	142.66

All diagrams are shown in 3rd angle projection with dimensions in millimetres

Insulators

Two part insulators

98 position unshrouded - HPF (with front removable socket contacts for vertical mounting applications only)

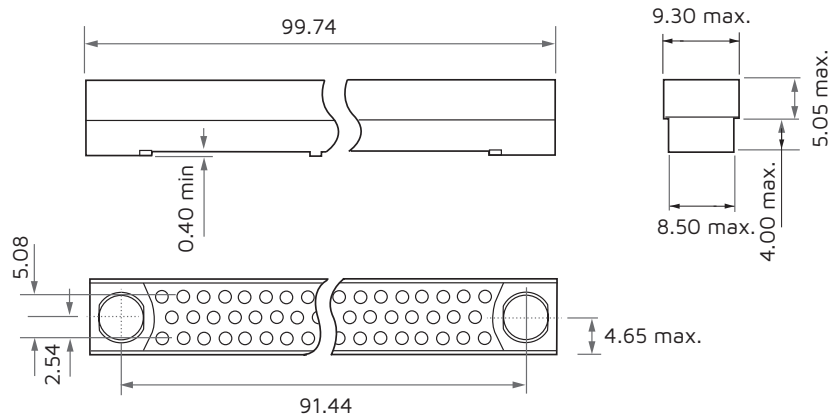

160 position unshrouded - HPF

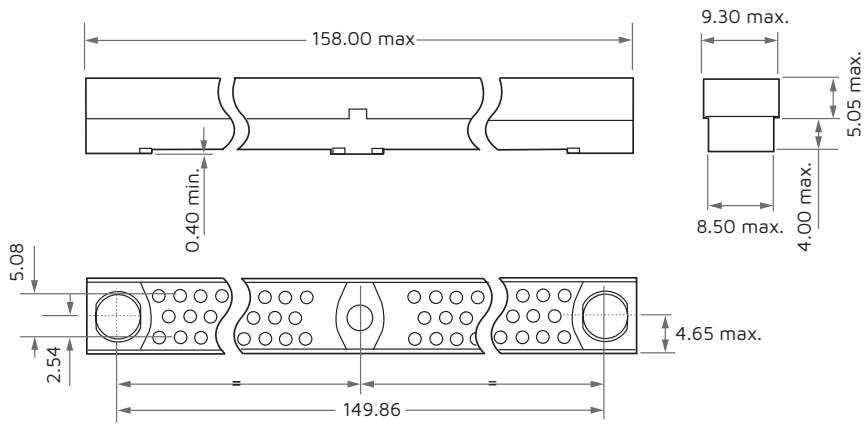

Insulators

Three row - style HPF

160 position unshrouded

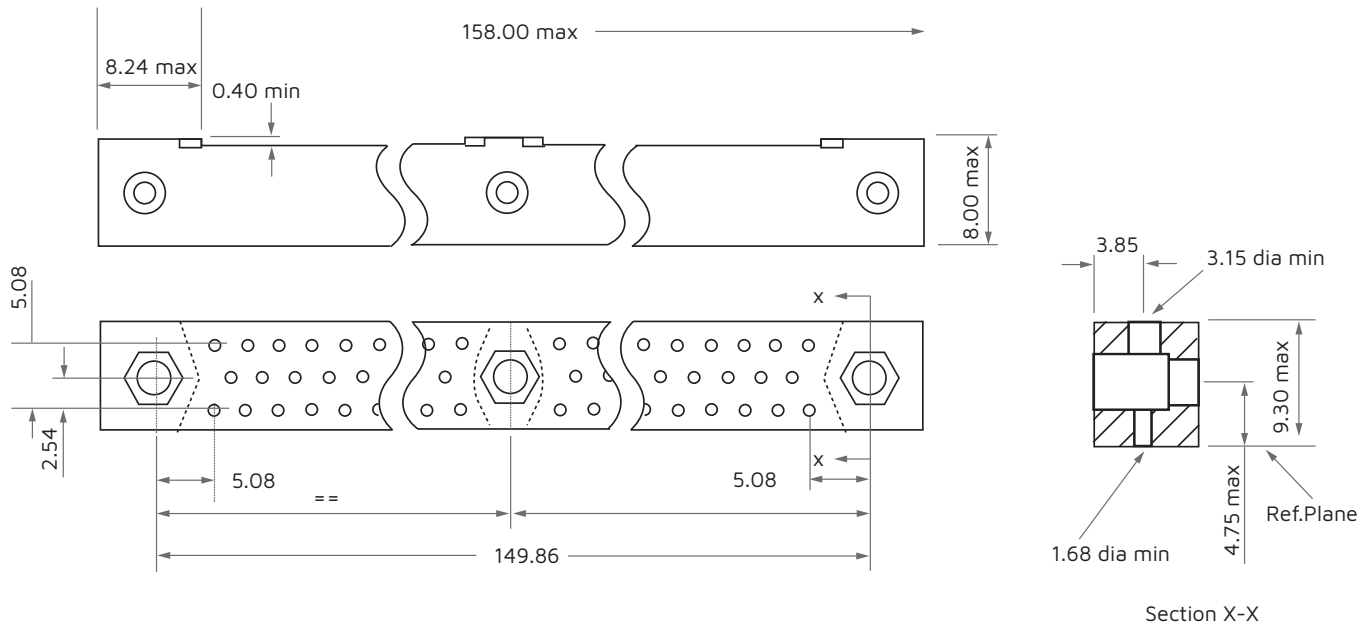

Three row - style HPM

160 position shrouded (fitted with male contacts only)

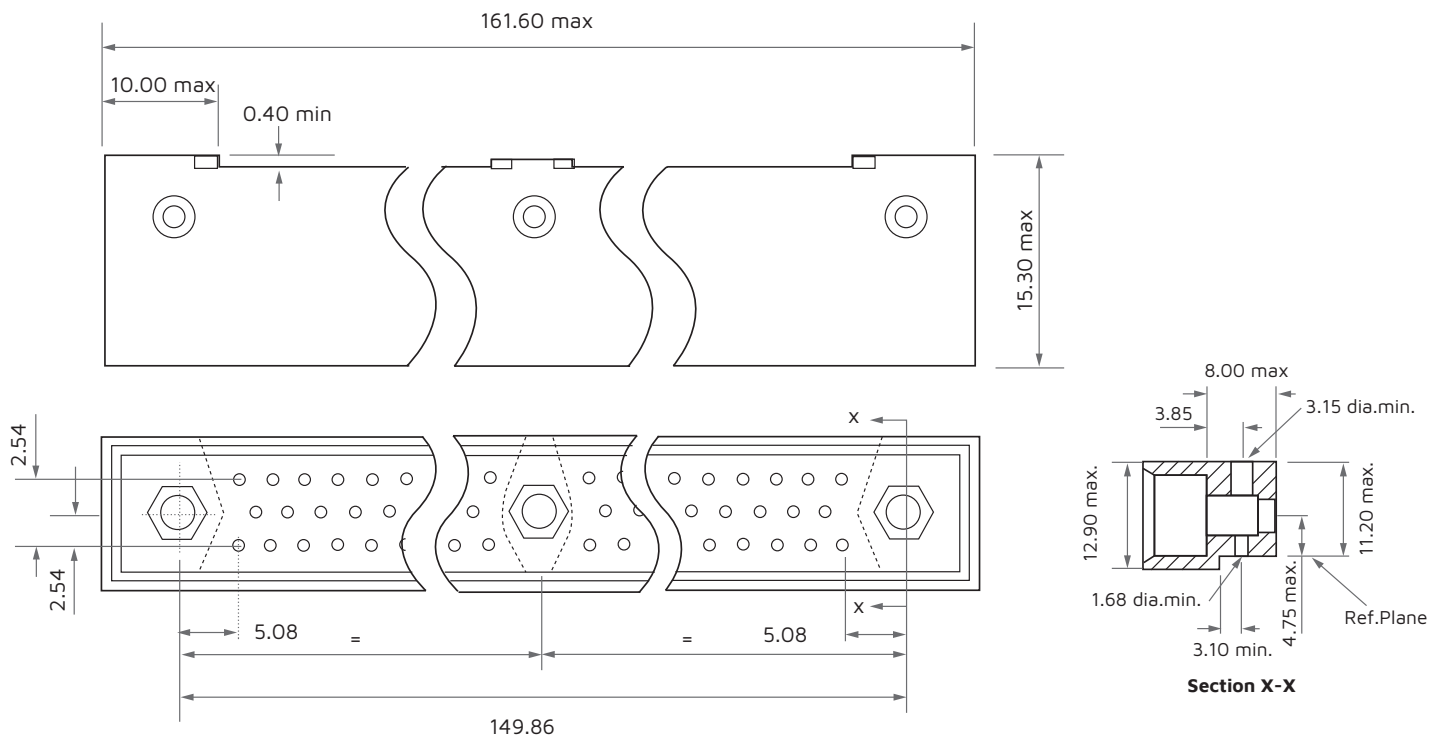

Insulators

Three row - style HPF

48 position unshrouded

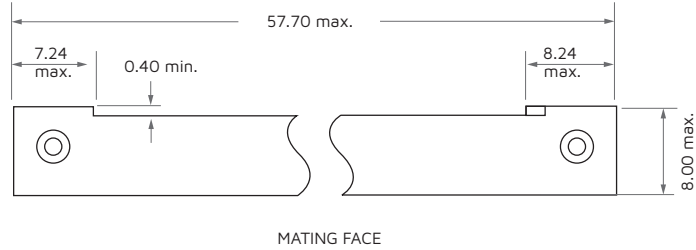

Please note the 048 way is the only non-symmetrical connector in this range. Therefore care should be taken to ensure correct identification code.

Contact identification

(13th Digit in Ordering Code) views on Mating face

Female Contact: BS spec. *2*; MIL spec. *7* (not MIL spec. qualified)

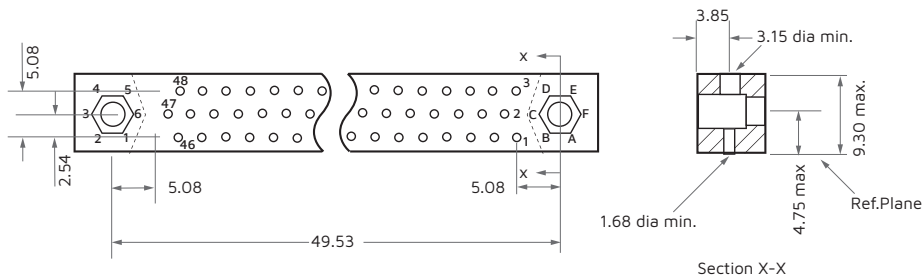

Male Contact: BS spec. *2*; MIL spec. *7* (not MIL spec. qualified)

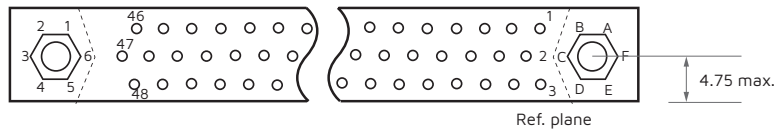

Female Contact: BS spec. *0*; MIL spec. *5* (not MIL spec. qualified)

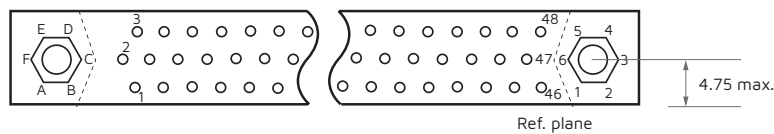

Male Contact: BS spec. *0*; MIL spec. *5* (not MIL spec. qualified)

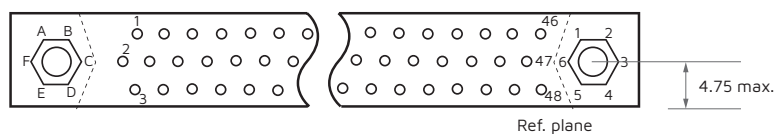

Insulators

Three row - style HPM

48 position shrouded (fitted with male contacts only)

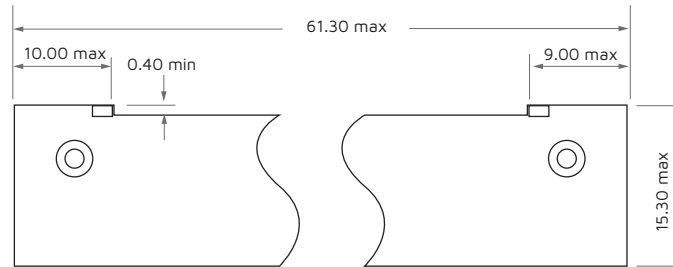

Contact identification

(13th Digit in Ordering Code) views on Mating face

Male Contact: BS spec. *2*; MIL spec. *7* (not MIL spec. qualified)

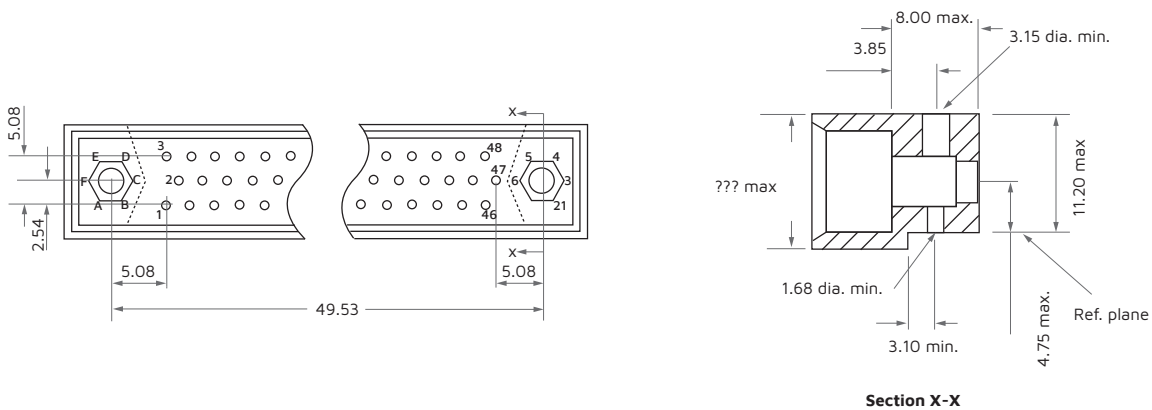

Male Contact: BS spec. *0*; MIL spec. *5* (not MIL spec. qualified)

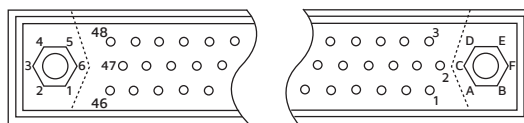

Insulators

Three row - style HPF

80 position unshrouded (cut from 160 position)

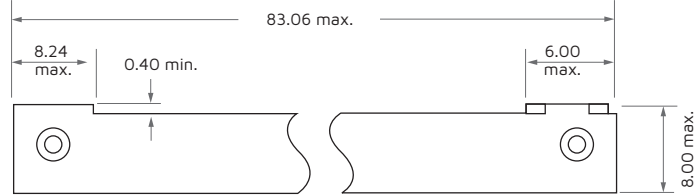

Contact identification

(13th digit in Ordering Code) views on mating face

Use with transverse mounting hardware only

Male contact *9*; Female contact *8*

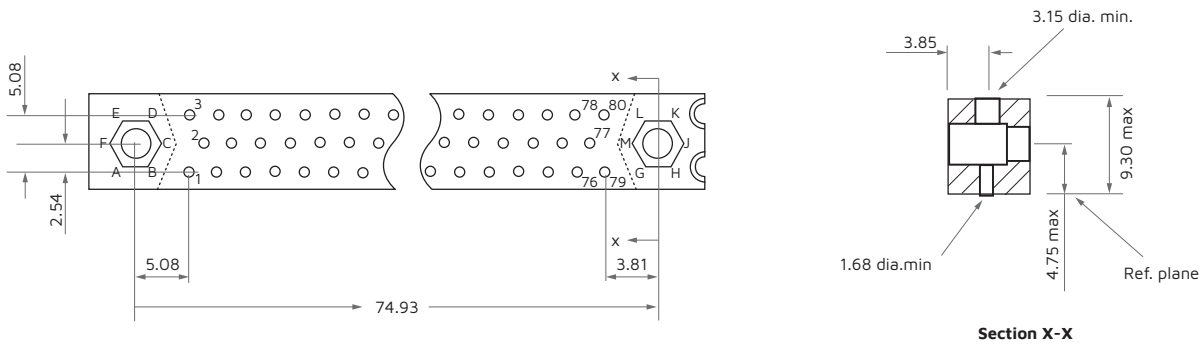

Use with vertical mounting hardware only

Male contact *9*; Female contact *8*

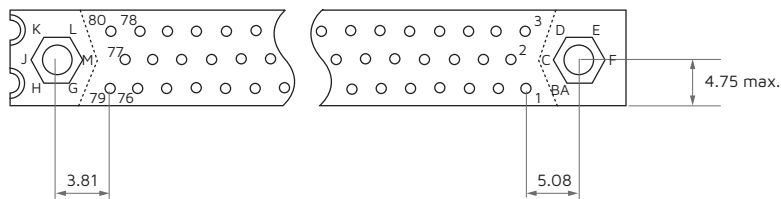

Insulators polarising data

Two row contacts

96 position illustrated

Views on mating face					
	Code (13th digit)	Contact gender	Left hand guide/polarising positions	Centre guide/polarising positions	Right hand guide/polarising positions
BS spec. standard	*2*	Female			
	0	Male		Ref. plane	
	2	Male			
	0	Female		Ref. plane	
MIL spec. standard	*7*	Female			
	5	Male		Ref. plane	
	7	Male			
	5	Female		Ref. plane	

Three row contacts

160 position illustrated

Views on mating face					
	Code (13th digit)	Contact gender	Left hand guide/polarising positions	Centre guide/polarising positions	Right hand guide/polarising positions
BS spec. standard	*2*	Female			
	0	Male		Ref. plane	
	2	Male			
	0	Female		Ref. plane	
MIL spec. standard	*7*	Female			
	5	Male		Ref. plane	
	7	Male			
	5	Female		Ref. plane	

Insulators

Panel preparation details

Two fixing positions

17, 29, 33, 41, 48, 53, 62, 65, 80, 98, 119 and 149 positions

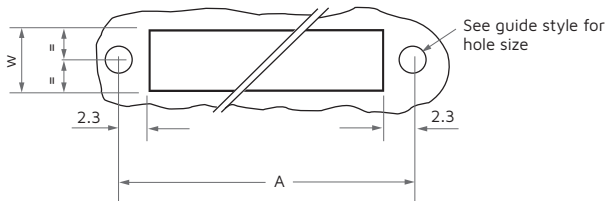

Three fixing positions

72, 84, 96, 120 and 160 positions

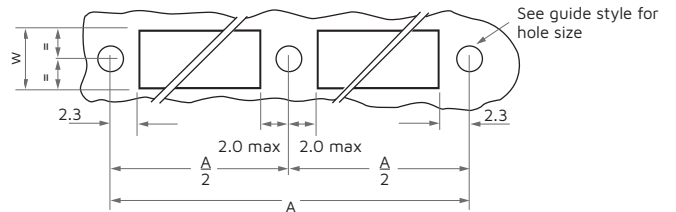

Floating mount style

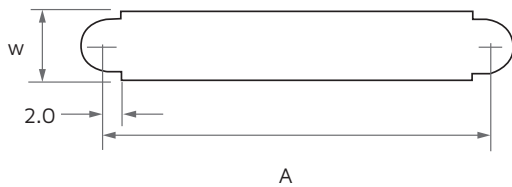

Floating mount style

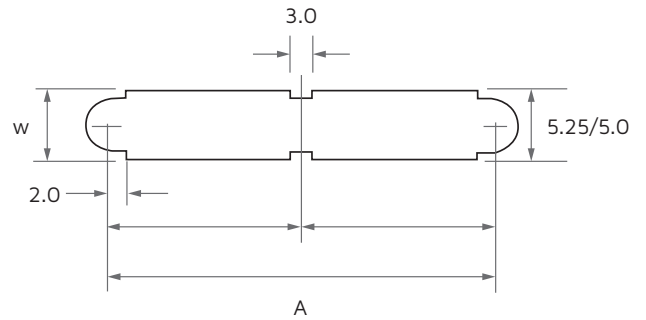

See guide styles for mounting hole sizes and panel thickness

Fixed mount style

	HPD/P	HPF/M	HPD/P	HPF/M
Dimension W	9.50	12.00	9.00	12.00

Board preparation details

17, 29, 33, 41, 48, 53, and 65 positions

72, 84, 96 and 120 positions

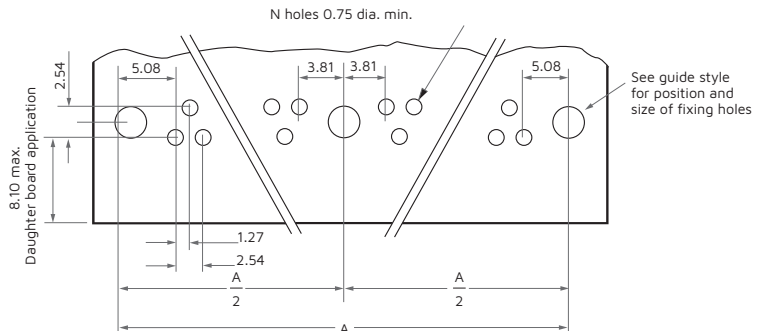
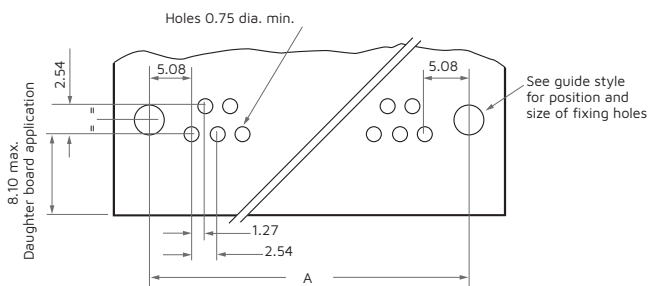

Insulators board preparation details

48 positions (views on component side of board)

HPM/HPF combination

HPM/HPF combination

Daughter board - HPM shrouded moulding

Daughter board - HPF unshrouded moulding

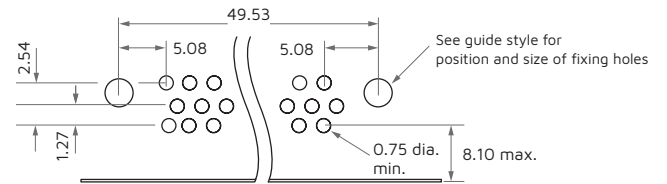
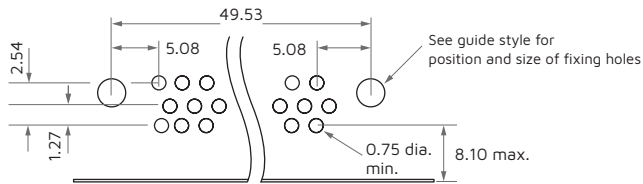

Mother Board - HPF unshrouded moulding

Mother Board - HPF unshrouded moulding

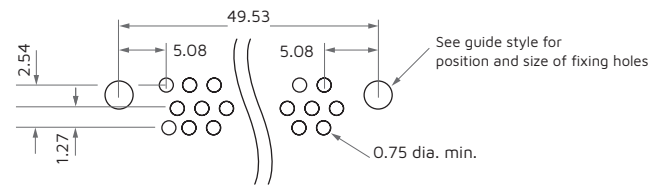
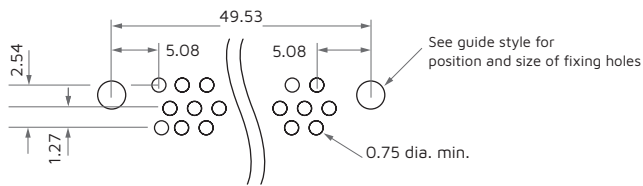

Insulators board preparation details

62, 80, 98, 119 And 149 positions (except 80 positions cut from 160 positions)

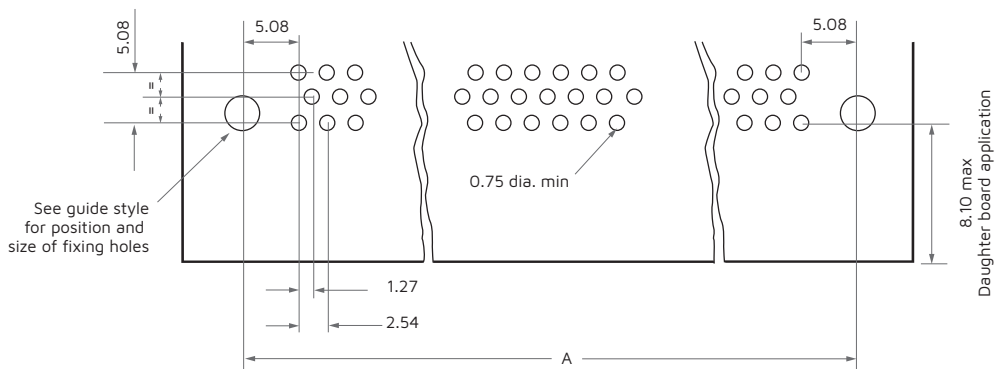

160 positions and 80 positions (cut from 160 positions)

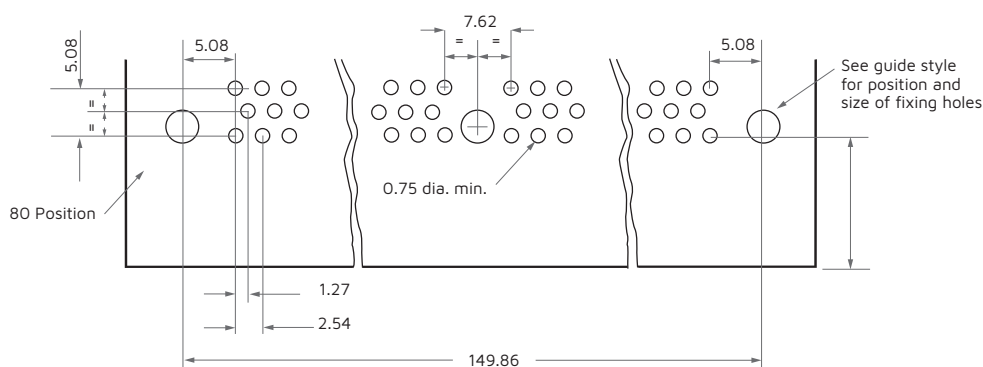

No. of positions	17	29	33	41	53	62	65
Dimension A nom.	30.48	45.72	50.80	60.96	76.20	60.96	91.44

No. of positions	72	80	84	96	98	119	120	149
Dimension A nom.	106.68	76.20	121.92	137.16	91.44	109.22	167.64	134.62

Contact termination and codes

This section includes details of the standard contact terminations used in most applications. Details of other available contact terminations can be obtained from the sales office of Smiths Connectors.

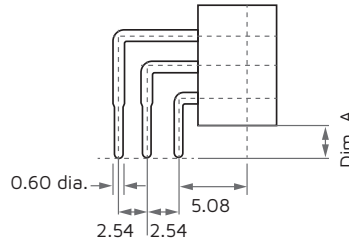

STYLE B/L

Through board solder - 90°

Term. style	Dimension A				Part no.					
	2 Row		3 Row		Male			Female		
	Max	Min	Max	Min	1st Row	2nd Row	3rd Row	1st Row	2nd Row	3rd Row
B	3.50	2.50	3.10	2.10	HPD 488/*	HPD 489/*	HPD 462/*	HPD 596/*	HPD 598/*	HPD 599/*
L	4.85	3.85	4.45	3.45	HPD 685/*	HPD 688/*	HPD 691/*	HPD 708/*	HPD 712/*	HPD 716/*

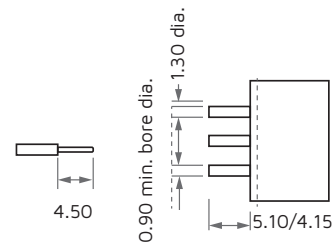
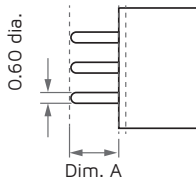

STYLE B/L

Through board solder - 90°

Term. style	Dimension A		Part no.	
	Max	Min	Male	Female
X	5.10	4.15	HPD 720/*	HPD 548/*
P	6.20	5.30	HPD 487/*	HPD 522/*

Style C supplied unassembled

Crimp barrel showing cable preparation

Term. style	Part no.	
	Male	Female
C	HPD 486/*	HPD 526/*

For 22, 24, and 26 AW wire

Guide torque information (HPD/HPF)

HPD/HPF torque values

Stainless steel guide

Range	Description	Torque
HPD/HPF	M2.5 mm vertical fixing (Styles EO, LO, and similar)	3 lb f*in max.
HPD/HPF	M1.6 mm transverse fixing non-counter sink (Styles KO, AO, and similar)	1 lb f*in max.
HPD/HPF	Jackscrew with cross pin fitted (Styles PO and similar)	1 lb f*in max.

Intermatability charts

Unpolarised guides intermateability chart

Female		Male																												
MIL SPEC. STYLE																														
BS STYLE																														
HPD																														
STYLE		AB	AC	AD	AE	AG	AH	AK	AL	AO	AP	AQ	AS	AV	AW	AZ	A4	A5	A6	A8	HO	QG	QH	QN	QO	QT	Q6	9K		
23	BB																													
	BD																													
	BE																													
	BF																													
	BN																													
	BO																													
	BU																													
	BW																													
	BX																													
	B3																													
38	B4																													
24	B6																													
	B7																													
39	B8																													
	B9																													
	MC																													
	MT																													
	M4																													
	M5																													
	M7																													
	M8																													
	OD																													
	5A																													
	5B																													
	5D																													
	5G																													

Quarter turn lock polarised guides intermateability chart

Female		Male																
MIL SPEC. STYLE																		
BS STYLE																		
HPD																		
STYLE		CH	CS	CT	SJ	SK	SL	SN	SO	ST	SX	S2	S3	S5	S6	S9	8K	8O
G	ZG																	
	ZK																	
	ZL																	
	ZM																	
22	ZN																	
	ZO																	
	37	ZT																
	34	ZW																
		ZX																
F	Z2																	
	Z4																	
	Z5																	
	Z6																	
36	Z8																	
	35	1A																
	31	1B																
		1M																
		1T																

Guide style

This Section includes details of the standard guide styles used in most applications. Details of other available guide styles can be obtained from Smiths Connectors sales offices.

Non rotating transverse guides (male) - unpolarised

Style NC/NH

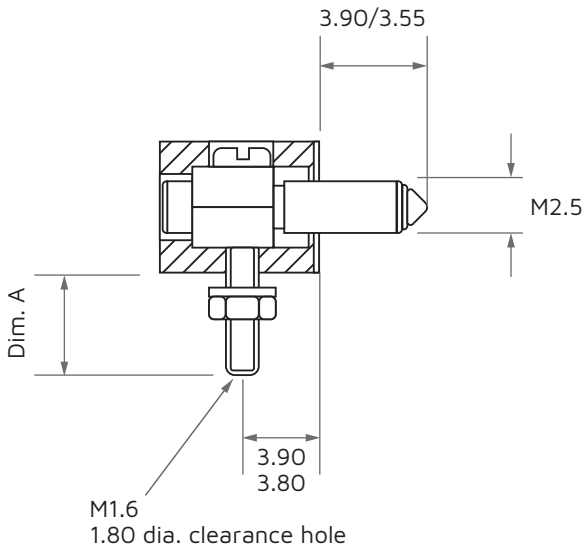

Style	Dimension A			
	2 row		3 row	
	Max	Min	Max	Min
NC	6.36	5.53	6.60	6.09
NH	5.30	4.59	5.71	4.88

When used in 62 & 80 position insulators add 0.28 mm to dimension A (3 Row)

Style NO

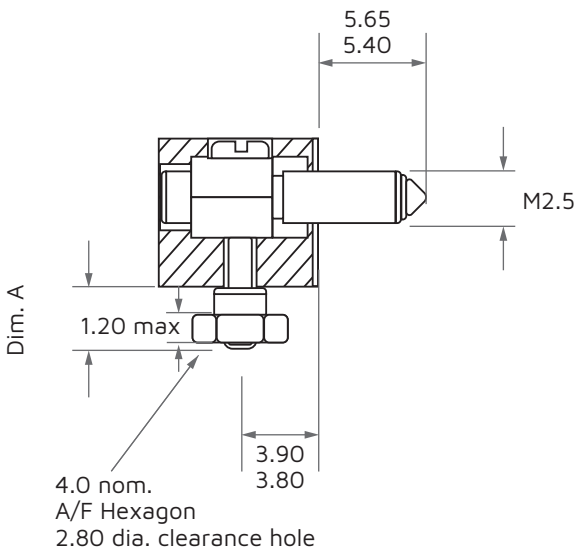

Style	Dimension A			
	2 row		3 row	
	Max	Min	Max	Min
NO	3.30	2.59	3.65	2.94

When used in 62 & 80 position insulators add 0.28 mm to Dimension A (3 Row)

Guide style

Jack guides (male) - unpolarised

Style P0

Rotating free connector

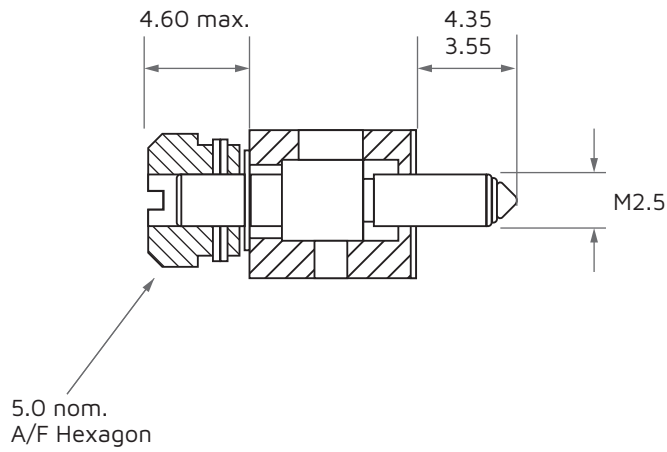

Style RA/RO

Non rotating transverse mounting

Style	Dimension A		Dimension B	
	Max	Min	Max	Min
RA	3.80	3.55	7.15	6.75
RO	5.65	5.40	7.15	6.75

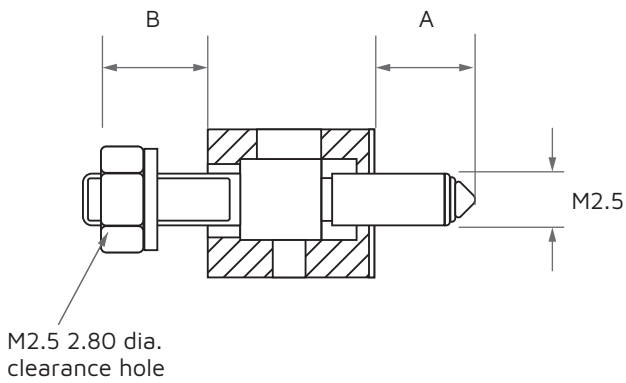

Guide style

Guides (male) - polarised

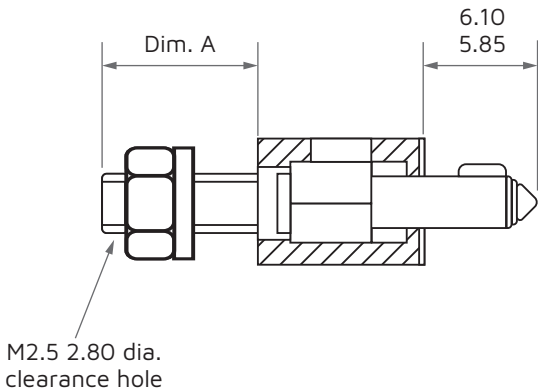
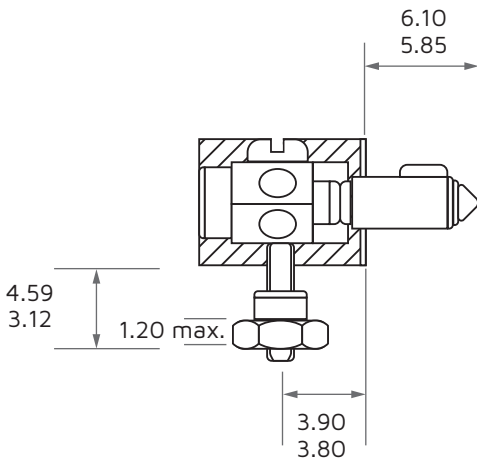
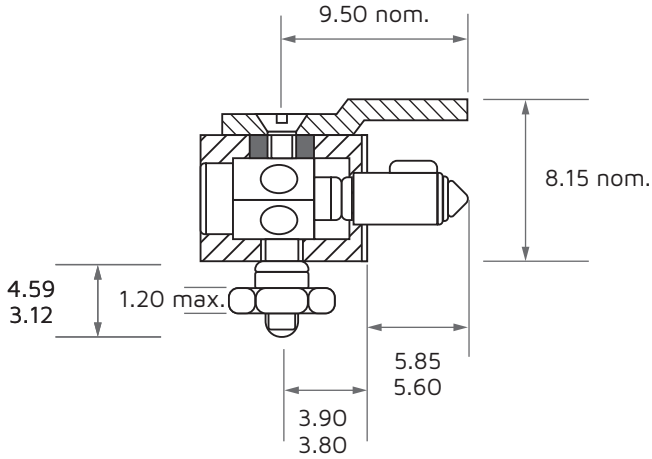

Style KB

Transverse mounting with pin protector for use with HPD/HPF only

Style	Dimension A			
	2 row		3 row	
	Max	Min	Max	Min
KB	5.30	4.59	5.71	4.88

When used in 62 & 80 position insulators deduct 0.25 mm to Dimension A (3 Row)

Style KO

Transverse mounting

Style	Dimension A			
	2 row		3 row	
	Max	Min	Max	Min
KO	3.30	2.59	3.65	2.94

When used in 62 & 80 position insulators add 0.28 mm to Dimension A (3 Row)

Style UO

Vertical mounting

Style	Dimension A	
	Max	Min
UO	7.15	6.75

Guide style

Guides (male) - unpolarised

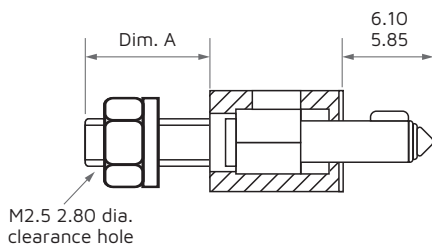
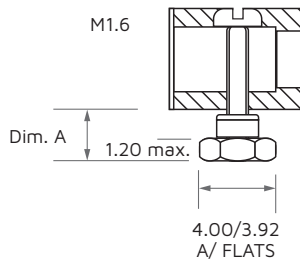
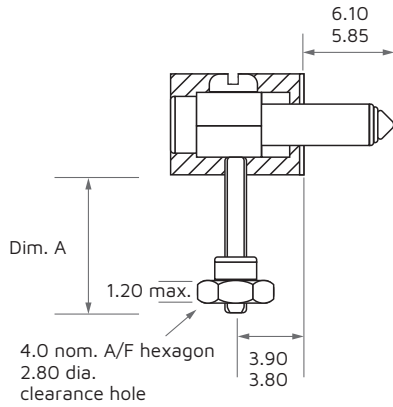

Jack guides (female) - unpolarised

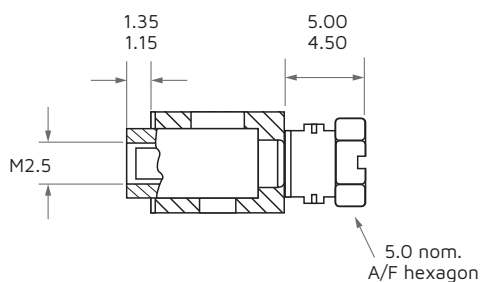
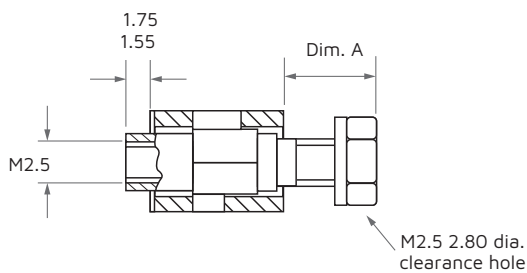

Style AO

Transverse mounting

Style	Dimension A			
	Max	Min	Max	Min
AO	3.30	2.59	3.65	2.94

Style HO

Transverse mounting

Style	Dimension A			
	Max	Min	Max	Min
HO	3.30	2.59	3.65	2.94

Style QO

Vertical mounting

Style	Dimension A	
	Max	Min
QO	7.15	6.75

Style JO

Non rotating vertical mounting

Style	Dimension A	
	Max	Min
JO	6.85	6.25

Style VO/VU

Rotating free connector

VO assembled

VU unassembled

Guide style

Guides (female) - unpolarised

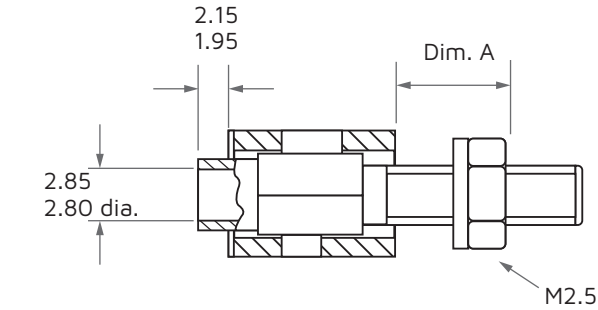

Style BO

Vertical mounting

Style	Dimension A	
	Max	Min
BO	7.15	6.75

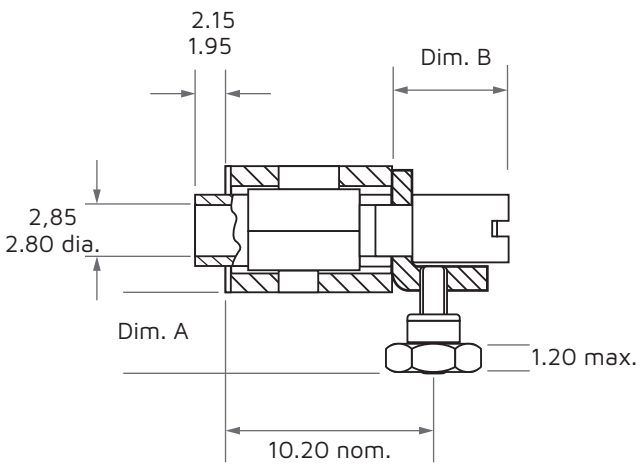

Style BU

Transverse mounting

Style	Dimension A		Dimension B			
	Max	Min	2 row		3 row	
			Max	Min	Max	Min
BU	5.60	5.20	7.30	6.90	7.50	7.10

Guides (female) quarter turn lock-polarised

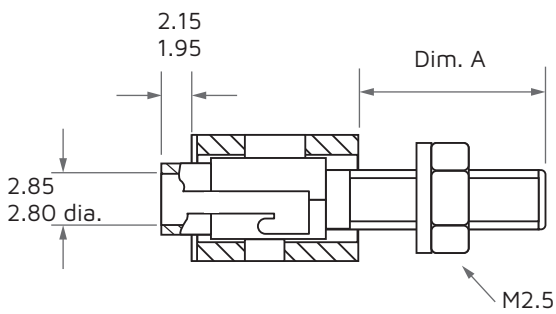

Style ZO

Vertical mounting

Style	Dimension A	
	Max	Min
ZO	7.15	6.75

Accessories

Pin protector (extruded polypropylene)

For plug assemblies HPD style insulator. Available to fit all sizes.

HPD 329/17
Indicates no. of positions

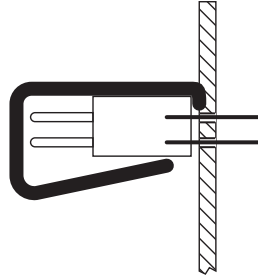
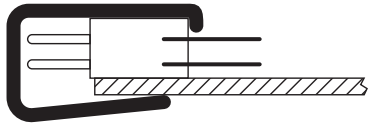

For plug assemblies HPD style insulator. Available to fit all sizes.

HPF 106/80
Indicates no. of positions

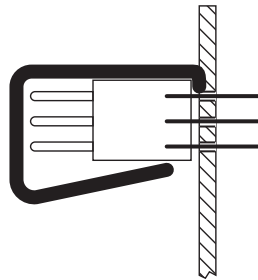
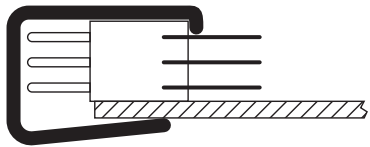

Accessories

Pin protector metal plate (blue anodised aluminium alloy)

Use with HPD and HPF connectors only

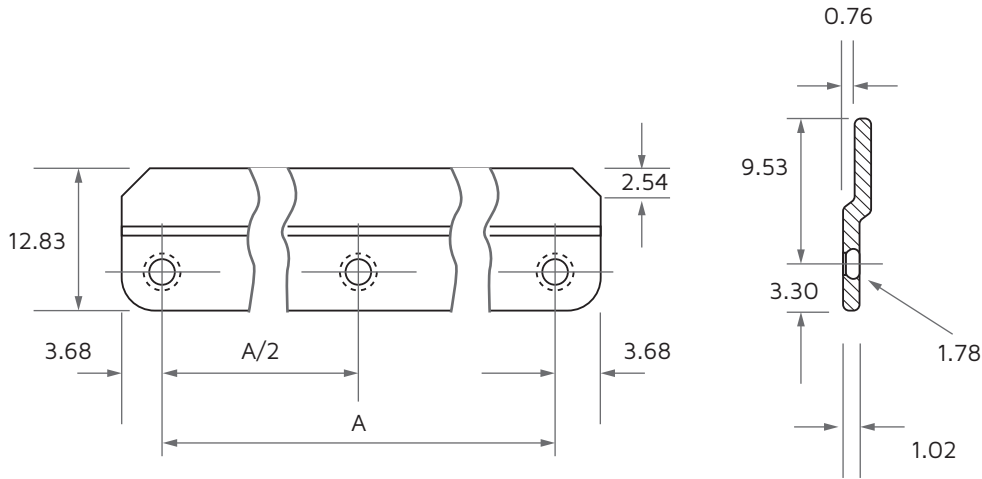

No. of positions	17	29	33	41	48	53	62	65	80	98	119	149
Dimension A	30.48	45.72	50.80	60.96	49.53	76.20	60.96	91.44	76.20	91.44	109.22	134.62
Protector part no.	HPD 630	HPD 631	HPD 632	HPD 633	HPD 1059	HPD 634	HPD 1030	HPD 635	HPD 634	HPD 640	HPD 947	HPD 1178
Spacer part no. (qty. 2 per)	HPD 654	HPD 654	HPD 654	HPD 654	HPD 655	HPD 654	HPD 655	HPD 654	HPD 655	HPD 655	HPD 655	HPD 655

No. of positions	72	84	96	120	160
Dimension A	106.68	121.92	137.16	167.64	149.86
Dimension A/2	53.34	60.96	68.86	83.82	74.93
Protector part no.	HPD 636	HPD 637	HPD 638	HPD 639	HPD 641
Spacer part no. (qty. 3 per)	HPD 654	HPD 654	HPD 654	HPD 654	HPD 655

Order countersunk head screws from following table, same quantity as spacers.

Style	Dimension A			
	2 row		3 row	
	Max	Min	Max	Min
20-234-2047-01	3.53	2.18		
20-234-2048-01	4.59	3.12		
20-234-2049-01	5.59	4.12		
HPD 1131	6.59	5.12	3.69	2.22
20-234-2050-01	7.59	6.12	4.69	3.22
HPD 1132	3.59	7.12	5.69	4.22
20-234-2051-01	9.59	8.12	6.69	5.22

Note: When using in 62 & 80 position insulators deduct 0.25 mm to Dimension A (3 Row)

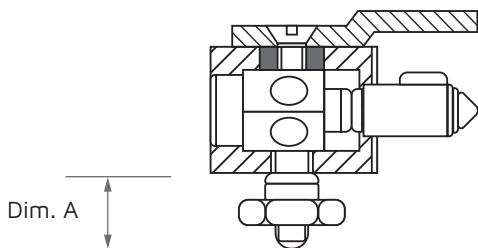

Accessories

Sealing gaskets

Code no. HPD 751 (fluorosilicone) 2 ROW GASKET

May be cut to suit all sizes by the user, above 65 positions two gaskets are required per connector.

Code NO. HPF 197 (silicone) 3 ROW GASKET

May be cut to suit all sizes by the user, above 98 positions two gaskets are required per connector.

Similar to that illustrated but with three row configuration.

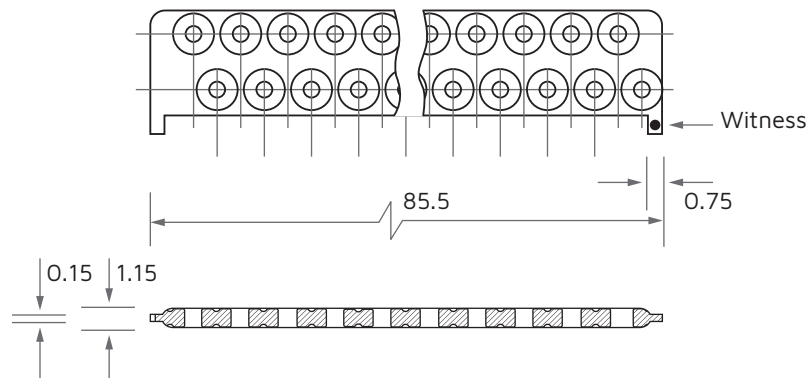

Alignment comb

For European market

Connector halves having 90° through board terminations are supplied fitted with an alignment comb to facilitate mounting to the board or panel.

Code HPD 354/No. of positions

Code HPF 107/No. of positions

Code HPM 111/No. of positions

Crimp information

AWG	Number and nominal diameter of wires	Crimp tool selector position
22	19 / 0.15 mm	5
24	7 / 0.20 mm	5
24	19 / 0.118 mm	4
26	7 / 0.15 mm	4

Tools

Contact extraction tool	HPD 286
Spare tips for above	HPD 280
Contact insertion tool	Use non ferrous long pointed tweezers
Crimp tool positioner	HPD 309
Crimp tool	MIL-C-22520/2.01

Disclaimer

All of the information included in this catalogue is believed to be accurate at the time of printing. It is recommended, however, that users should independently evaluate the suitability of each product for their intended application and be sure that each product is properly installed, used and maintained to achieve desired results.

Smiths Interconnect makes no warranties as to the accuracy or completeness of the information, and disclaims any liability regarding its use.

Smiths Interconnect reserves the right to modify design and specifications, in order to improve quality, keep pace with technological development or meet specific production requirements.

No reproduction or use without express permission of editorial and pictorial content, in any manner.

Product Portfolio

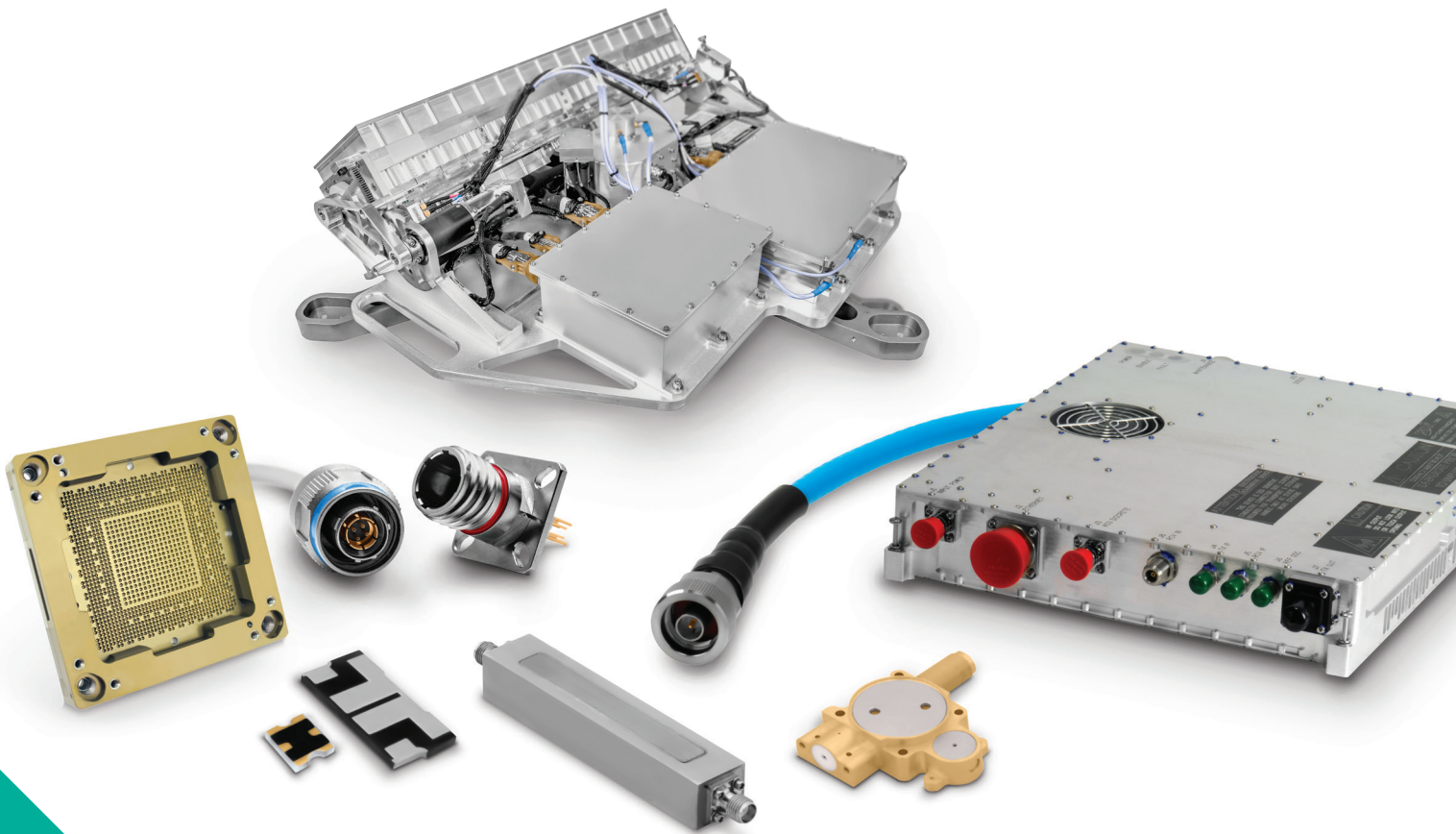

- Antenna Systems
- Cable Assemblies
- Connector Solutions
- Ferrite Components and Assemblies
- RF Filter Components and Assemblies
- Integrated Microwave Assemblies
- Millimetre-Wave Solutions
- RF Components
- Test Sockets and WLCSP Probe Heads
- Time & Frequency Systems

Worldwide Support

Connectors

Americas

Sales

connectors.uscsr@smithsinterconnect.com

Technical Support

connectors.ustechsupport@smithsinterconnect.com

Europe

Sales

connectors.emeacsr@smithsinterconnect.com

Technical Support

connectors.emeatechsupport@smithsinterconnect.com

Asia

Sales

asiacsr@smithsinterconnect.com

Technical Support

asiatechsupport@smithsinterconnect.com

Fibre Optics & RF Components

Americas

Sales

focom.uscsr@smithsinterconnect.com

Technical Support

focom.techsupport@smithsinterconnect.com

Europe

Sales

focom.emeacsr@smithsinterconnect.com

Technical Support

focom.techsupport@smithsinterconnect.com

Asia

Sales

focom.asiacsr@smithsinterconnect.com

Technical Support

focom.techsupport@smithsinterconnect.com

Semiconductor Test

Americas

Sales

semi.uscsr@smithsinterconnect.com

Technical Support

semi.techsupport@smithsinterconnect.com

Europe

Sales

semi.emeacsr@smithsinterconnect.com

Technical Support

semi.techsupport@smithsinterconnect.com

Asia

Sales

semi.asiacsr@smithsinterconnect.com

Technical Support

semi.techsupport@smithsinterconnect.com

RF/MW Subsystems

Americas, Europe & Asia

Sales

subsystems.csr@smithsinterconnect.com

Technical Support

subsystems.techsupport@smithsinterconnect.com

Connecting Global Markets

smithsinterconnect.com

