

MHD / MDD / MDP

Connectors Series

PCB High Density Connectors

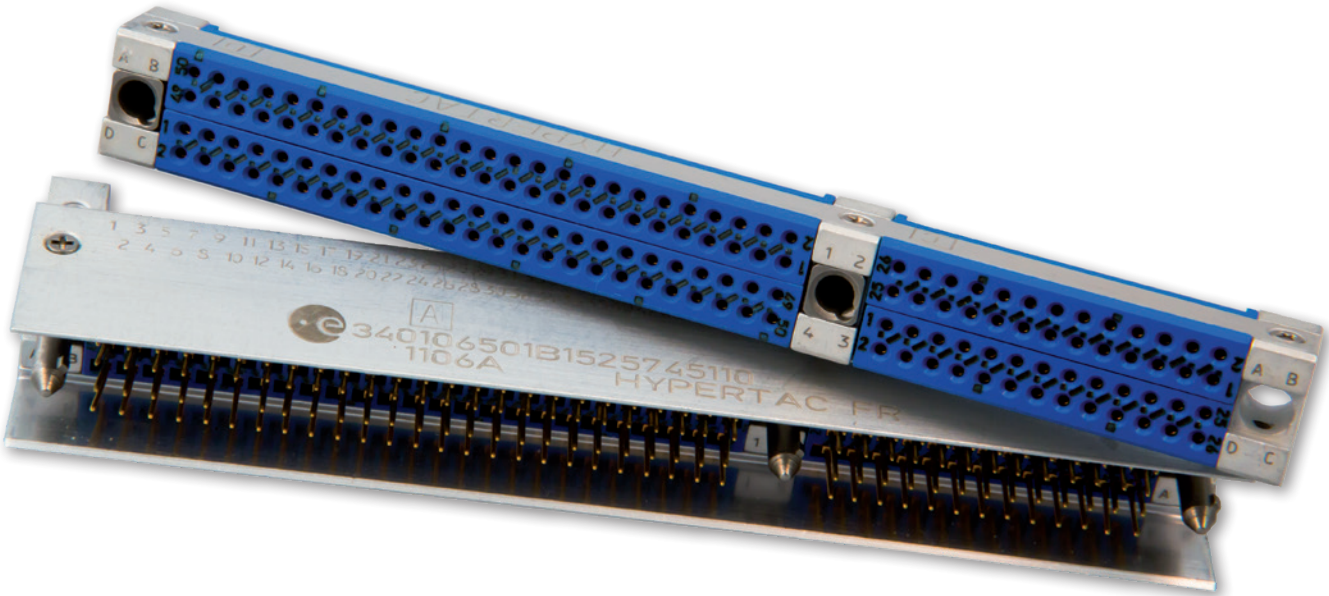

Hypertac[®] Hyperboloid Technology

Smiths Interconnect offers an extensive range of superior contact technologies suitable for standard and custom solutions. Hypertac[®] (HYPERboloid conTACT) is the original superior performing hyperboloid contact technology designed for use in all applications and in harsh and demanding environments where high reliability and safety are critical. The inherent electrical and mechanical characteristics of the Hypertac hyperboloid contact ensures unrivaled performance in terms of reliability, number of mating cycles, low contact force and minimal contact resistance. The shape of the contact sleeve is formed by hyperbolically arranged contact wires, which align themselves elastically as contact lines around the pin, providing a number of linear contact paths.

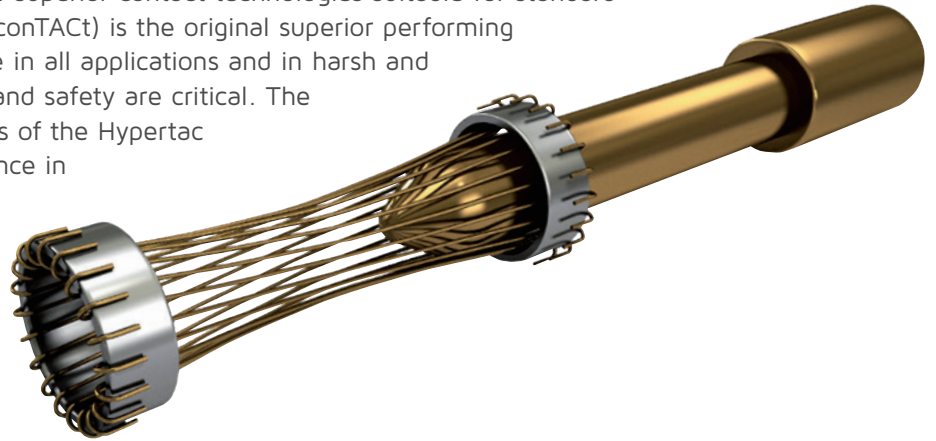

Features

Low insertion/extraction forces

The angle of the socket wires allows tight control of the pin insertion and extraction forces. The spring wires are smoothly deflected to make line contact with the pin.

Long contact life

The smooth and light wiping action minimizes wear on the contact surfaces. Contacts perform up to 100,000 insertion/extraction cycles with minimal degradation in performance.

Lower contact resistance

The design provides a far greater contact area and the wiping action of the wires insures a clean and polished contact surface. Our contact technology has about half the resistance of conventional contact designs.

Higher current ratings

The design parameters of the contact (e.g., the number, diameter and angle of the wires) may be modified for any requirement. The number of wires can be increased so the contact area is distributed over a larger surface. Thus, the high current carried by each wire because of its intimate line contact, can be multiplied many times.

Immunity to shock & vibration

The low mass and resultant low inertia of the wires enable them to follow the most abrupt or extreme excursions of the pin without loss of contact. The contact area extends 360° around the pin and is uniform over its entire length. The 3 dimensional symmetry of the Hypertac contact design guarantees electrical continuity in all circumstances.

Benefits

High density interconnect systems

Significant reductions in size and weight of sub-system designs. No additional hardware is required to overcome mating and unmating forces.

Low cost of ownership

The Hypertac contact technology will surpass most product requirements, thus eliminating the burden and cost of having to replace the connector or the entire subsystem.

Low power consumption

The lower contact resistance of our technology results in a lower voltage drop across the connector reducing the power consumption and heat generation within the system.

Maximum contact performance

The lower contact resistance of the Hypertac contact reduces heat build-up; therefore Hypertac contacts are able to handle far greater current in smaller contact assemblies without the detrimental effects of high temperature.

Reliability under harsh environments

Harsh environmental conditions require connectors that will sustain their electrical integrity even under the most demanding conditions such as shock and vibration. The Hypertac contact provides unmatched stability in demanding environments when failure is not an option.

Contents

MHD Series

Technical Characteristics.....	2
How To Order	3
Modules Configuration	4
Standard Plugging Stages.....	5
Termination Styles	6
Connector Dimensions	7
Guiding Devices.....	13
Contact Board Preparation Details	14
Power & High Frequency Contacts (NFC 93569)	19

MDD Series

Technical Characteristics.....	20
How To Order	21
Modules Configuration	21
Standard Plugging Stages.....	22
Termination Styles	23
Connector Dimensions	24
Guiding Devices.....	25
Contact Board Preparation Details	26

MDP Series

Technical Characteristics.....	27
How To Order	28
Connector Dimensions	29
Guide and Termination Styles	30
Contact Board Preparation Details	31

Technical Characteristics

Materials & Platings

Insulator	Diallyl Phtalate UL94V0
Frame	Aluminum Alloy
Contact	Copper Alloy
Guide	Brass + Ni plating or Stainless Steel
Contact plating	Ni + Au

Environmental

Temperature range	-55° C to 125° C
Safety of contact from extraction	Statical 2 mm / 0.079 in. Dynamical 1.80 mm / 0.071 in.
Mating cycles	5000
Withdrawal forces	≤0.5 N
Special contacts	According to NFC 93569

Electrical

Contact resistance	Signal ≤12 mΩ
	Power ≤2 mΩ
Current rating	Signal 3 A
	Power 15 A
Insulation	>104 MΩ
Voltage rating	200 V
Proof voltage	800 V
Contact diameter	Signal 0.50 mm
	Power 2.00 mm
Impedance	Coaxial 50 Ω

How To Order



Code ESA	3401-065 01B				
Code HYPERTAC	MHD				
	1	2	3	4	5

1 Series																													
2 Arrangement	<table border="0"> <tr> <td>Ⓢ 052</td> <td>Ⓢ 152</td> <td>Ⓢ 252</td> <td>Ⓢ 352</td> <td>5HA</td> <td>1HB</td> <td>6XA</td> </tr> <tr> <td>Ⓢ 100</td> <td>Ⓢ 200</td> <td>Ⓢ 300</td> <td>Ⓢ 400</td> <td>2XA</td> <td>7XB</td> <td>3HB</td> </tr> </table>	Ⓢ 052	Ⓢ 152	Ⓢ 252	Ⓢ 352	5HA	1HB	6XA	Ⓢ 100	Ⓢ 200	Ⓢ 300	Ⓢ 400	2XA	7XB	3HB														
Ⓢ 052	Ⓢ 152	Ⓢ 252	Ⓢ 352	5HA	1HB	6XA																							
Ⓢ 100	Ⓢ 200	Ⓢ 300	Ⓢ 400	2XA	7XB	3HB																							
3 Part - Polarity Plating	<table border="0"> <tr> <td>13</td> <td>Ⓢ 55 Male Plug Standard plating</td> <td>22</td> <td>Ⓢ 44 Female Receptacle Standard plating</td> </tr> <tr> <td>17</td> <td>Ⓢ 57 Male Plug Pretinned</td> <td>26</td> <td>Ⓢ 46 Female Receptacle Pretinned</td> </tr> </table>	13	Ⓢ 55 Male Plug Standard plating	22	Ⓢ 44 Female Receptacle Standard plating	17	Ⓢ 57 Male Plug Pretinned	26	Ⓢ 46 Female Receptacle Pretinned																				
13	Ⓢ 55 Male Plug Standard plating	22	Ⓢ 44 Female Receptacle Standard plating																										
17	Ⓢ 57 Male Plug Pretinned	26	Ⓢ 46 Female Receptacle Pretinned																										
4 Termination Styles	<table border="0"> <tr> <td>Ⓢ 10</td> <td>90° termination, PCB thickness 1.60</td> <td>Ⓢ 11¹⁾</td> <td>90° termination, PCB thickness 2.40</td> </tr> <tr> <td>Ⓢ 12²⁾</td> <td>90° termination, PCB thickness 3.20</td> <td>Ⓢ 30</td> <td>Straight termination, PCB thickness 2.40</td> </tr> <tr> <td>Ⓢ 31</td> <td>Straight termination, PCB thickness 3.20</td> <td>41</td> <td>SMT³⁾ - PCB thickness 1.60</td> </tr> <tr> <td>42</td> <td>SMT³⁾ - PCB thickness 3.20</td> <td>Ⓢ 43</td> <td>SMT³⁾ - PCB thickness 2.40</td> </tr> <tr> <td>44</td> <td>SMT³⁾ - Uncentered PCB thickness 3.80</td> <td>Ⓢ 45</td> <td>SMT³⁾ - Uncentered PCB thickness 1.60</td> </tr> <tr> <td>Ⓢ 47</td> <td>SMT³⁾ - Uncentered PCB thickness 2.40</td> <td>Ⓢ 91</td> <td>Female / male saver⁴⁾</td> </tr> </table>	Ⓢ 10	90° termination, PCB thickness 1.60	Ⓢ 11 ¹⁾	90° termination, PCB thickness 2.40	Ⓢ 12 ²⁾	90° termination, PCB thickness 3.20	Ⓢ 30	Straight termination, PCB thickness 2.40	Ⓢ 31	Straight termination, PCB thickness 3.20	41	SMT ³⁾ - PCB thickness 1.60	42	SMT ³⁾ - PCB thickness 3.20	Ⓢ 43	SMT ³⁾ - PCB thickness 2.40	44	SMT ³⁾ - Uncentered PCB thickness 3.80	Ⓢ 45	SMT ³⁾ - Uncentered PCB thickness 1.60	Ⓢ 47	SMT ³⁾ - Uncentered PCB thickness 2.40	Ⓢ 91	Female / male saver ⁴⁾				
Ⓢ 10	90° termination, PCB thickness 1.60	Ⓢ 11 ¹⁾	90° termination, PCB thickness 2.40																										
Ⓢ 12 ²⁾	90° termination, PCB thickness 3.20	Ⓢ 30	Straight termination, PCB thickness 2.40																										
Ⓢ 31	Straight termination, PCB thickness 3.20	41	SMT ³⁾ - PCB thickness 1.60																										
42	SMT ³⁾ - PCB thickness 3.20	Ⓢ 43	SMT ³⁾ - PCB thickness 2.40																										
44	SMT ³⁾ - Uncentered PCB thickness 3.80	Ⓢ 45	SMT ³⁾ - Uncentered PCB thickness 1.60																										
Ⓢ 47	SMT ³⁾ - Uncentered PCB thickness 2.40	Ⓢ 91	Female / male saver ⁴⁾																										
5 Guide Styles	<table border="0"> <tr> <td>Ⓢ 110</td> <td>Male polarized, transverse mount, standard plug</td> <td>Ⓢ 111</td> <td>Male polarized, vertical mount</td> </tr> <tr> <td>Ⓢ 121</td> <td>Female polarized, vertical mount</td> <td>122</td> <td>Female polarized, vertical mount</td> </tr> <tr> <td>Ⓢ 124</td> <td>Female polarized, transverse mount</td> <td>125</td> <td>Male unpolarized, transverse mount</td> </tr> <tr> <td>126</td> <td>Female unpolarized, vertical mount</td> <td>130</td> <td>Female polarized, vertical mount</td> </tr> <tr> <td>131</td> <td>Female polarized, vertical mount</td> <td>133</td> <td>Female all polarized, transverse mount</td> </tr> <tr> <td>Ⓢ 134</td> <td>Female polarized, transverse mount</td> <td>190</td> <td>Female power or mass contact, vertical mount</td> </tr> <tr> <td>191</td> <td>Male power or mass contact, transverse mount</td> <td>Ⓢ 201</td> <td>¼ turn, free connector</td> </tr> </table>	Ⓢ 110	Male polarized, transverse mount, standard plug	Ⓢ 111	Male polarized, vertical mount	Ⓢ 121	Female polarized, vertical mount	122	Female polarized, vertical mount	Ⓢ 124	Female polarized, transverse mount	125	Male unpolarized, transverse mount	126	Female unpolarized, vertical mount	130	Female polarized, vertical mount	131	Female polarized, vertical mount	133	Female all polarized, transverse mount	Ⓢ 134	Female polarized, transverse mount	190	Female power or mass contact, vertical mount	191	Male power or mass contact, transverse mount	Ⓢ 201	¼ turn, free connector
Ⓢ 110	Male polarized, transverse mount, standard plug	Ⓢ 111	Male polarized, vertical mount																										
Ⓢ 121	Female polarized, vertical mount	122	Female polarized, vertical mount																										
Ⓢ 124	Female polarized, transverse mount	125	Male unpolarized, transverse mount																										
126	Female unpolarized, vertical mount	130	Female polarized, vertical mount																										
131	Female polarized, vertical mount	133	Female all polarized, transverse mount																										
Ⓢ 134	Female polarized, transverse mount	190	Female power or mass contact, vertical mount																										
191	Male power or mass contact, transverse mount	Ⓢ 201	¼ turn, free connector																										

- 1) Available for receptacle connector
- 2) Available for plug connector
- 3) Surface Mount Termination
- 4) Consult us – PCB thickness is in mm

Modules Configuration

Single Arrangements

Receptacle Mating Side Views

Mixed Arrangements

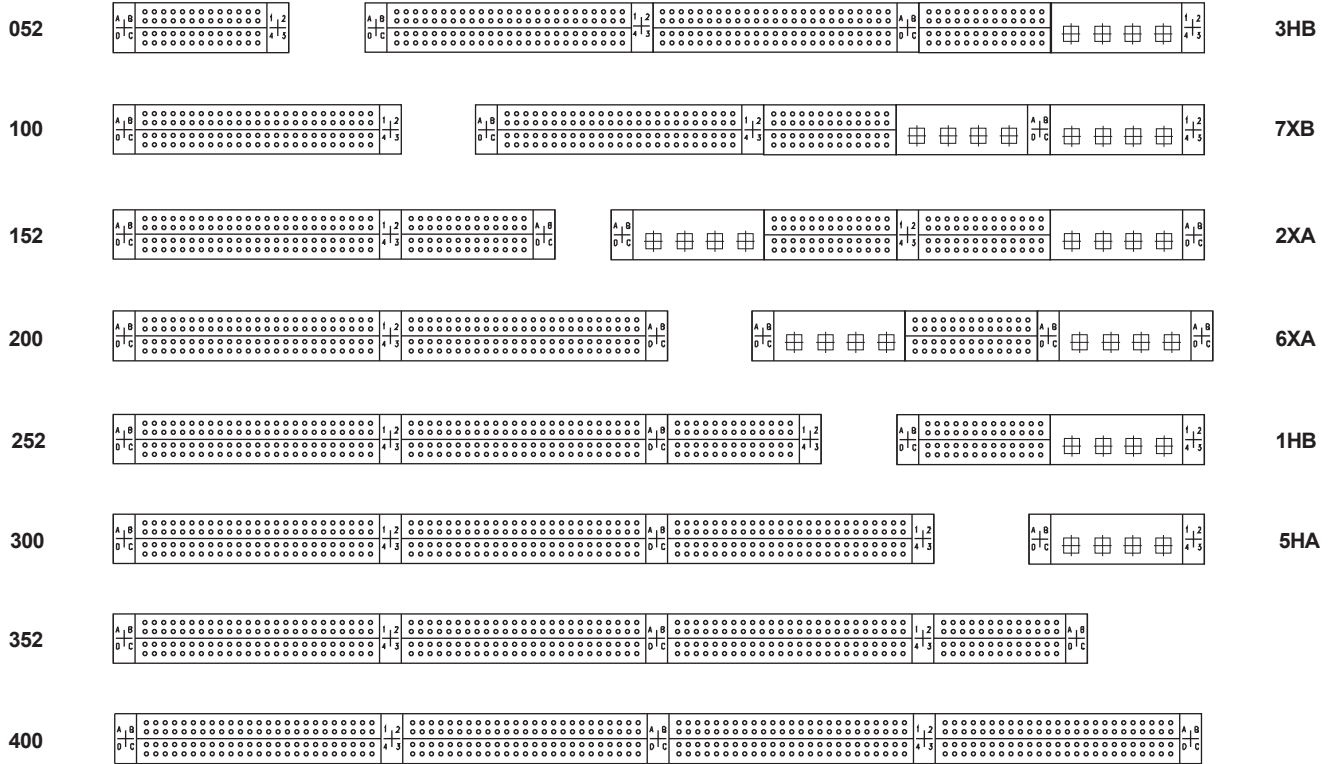

26 ways module

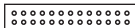

50 ways module

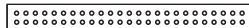

4 ways module (special contacts)

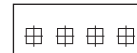

Space which can receive:
 2x50 ways module
 or
 2x26 ways module
 1x4 ways module
 or
 2x4 ways module

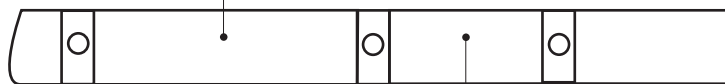

Space which can receive:
 2x26 ways module
 or
 1x4 ways module

Standard Plugging Stages

Misalignment

Longitudinal

Lateral

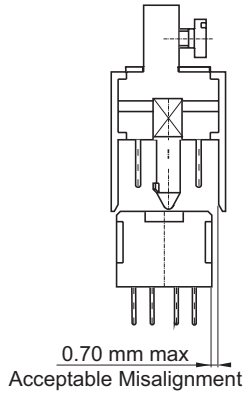
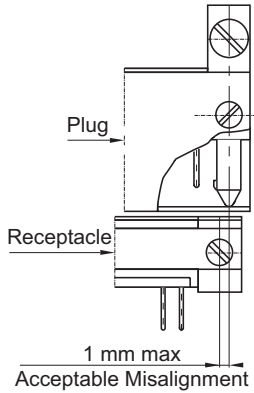

Gap

Lateral

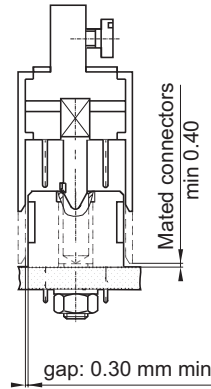

Tilting

Longitudinal

Lateral

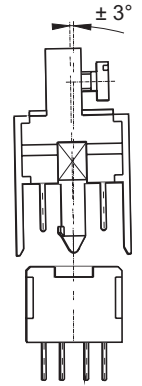
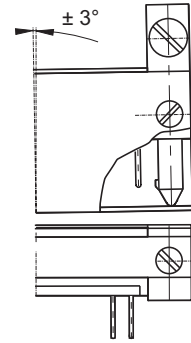

Mounting Examples

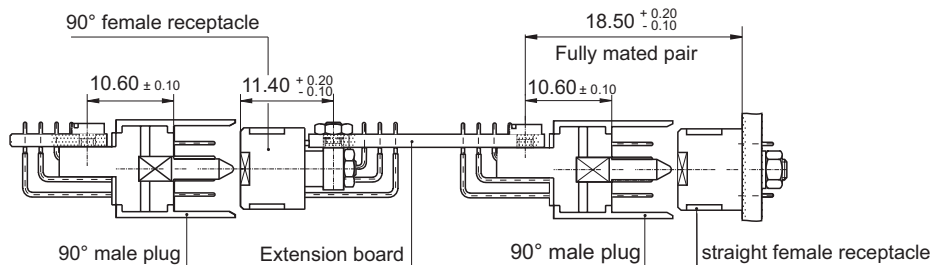
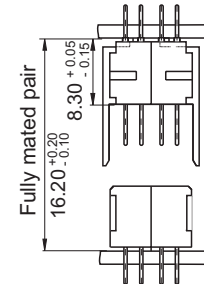
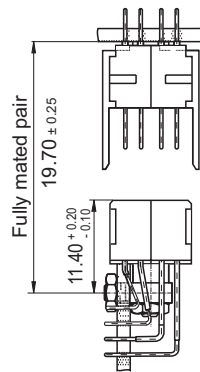
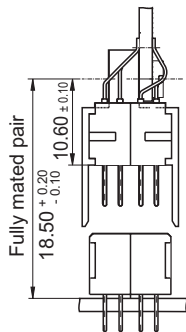

Displacement

Max displacement allowed while plugging in the receptacle: 0.15 mm in all plugged in connector ways.

Termination Styles

Receptacle

Through board solder - 90°

Ref: 10
PCB: 1.44 - 1.76
A = $3.25^{+0.15}_{-0.45}$
B = 6 max

Ref: 11
PCB: 1.98 - 2.42
A = $3.85^{+0.15}_{-0.45}$
B = 6.60 max

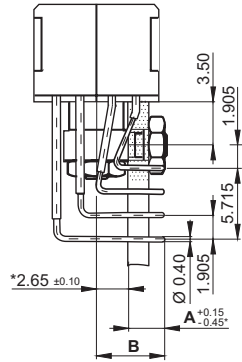

* Unbuild-up of tolerances

Through board solder - Straight

Ref: 30
PCB: 2.16 - 2.64
A = 3.50 min
A = 4.00 max

Ref: 31
PCB: 2.88 - 5.50
A = 6.10 min
A = 6.60 max

Ref: 96
PCB: 3.42 - 4.18
A = 4.70 min
A = 5.10 max

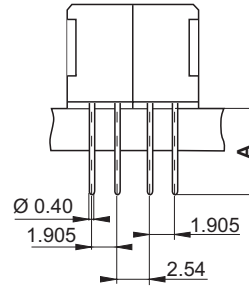

Plug

Through board solder - 90°

Ref: 10
PCB: 1.44 - 1.76
A = 5.95 max

Ref: 12
PCB: 2.88 - 3.52
A = 7.60 max

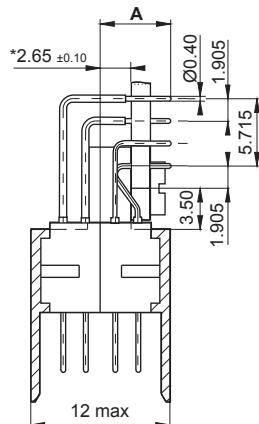

* Unbuild-up of tolerances

Through board solder - Straight

Ref: 30
PCB: 2.16 - 2.64
A = 3.50 min
A = 4.00 max

Ref: 31
PCB: 2.88 - 3.52
A = 4.60 min
A = 5.10 max

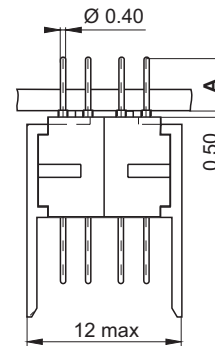

Surface mount (centered PCB)

Ref: 41
PCB: 1.44 - 1.76
A = 5.20 max

Ref: 42
PCB: 2.88 - 3.52
A = 4.40 max

Ref: 43
PCB: 2.16 - 2.64
A = 4.80 max

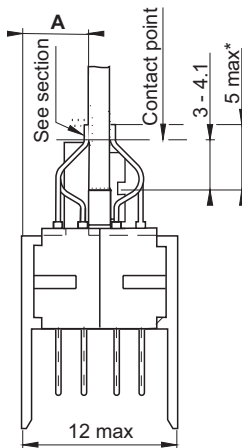

*5.50 for ref: 43

Section of termination
Mandatory only for
termination 43, 45 & 47
(ESCC 3401-065)

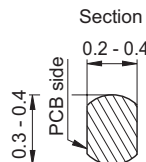

Surface mount (uncentered PCB)

Ref: 44
PCB: 3.60 - 4.00
A = 4.40 max

Ref: 45
PCB: 1.44 - 2.40
A = 7 max

Ref: 47
PCB: 2.16 - 2.70
A = 7 max

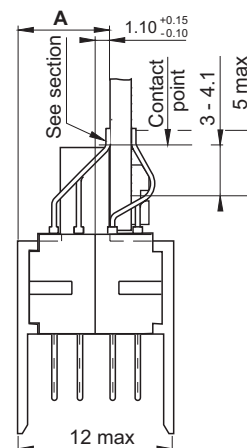

Connector Dimensions

Plug

Receptacle

52 contacts

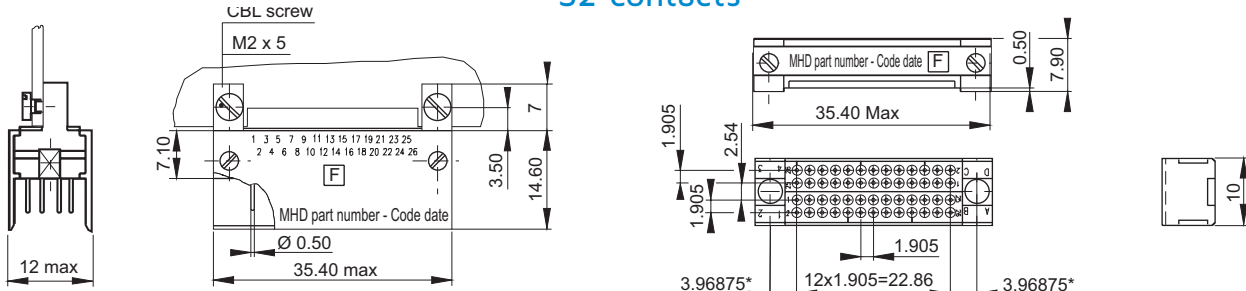

View mating side

100 contacts

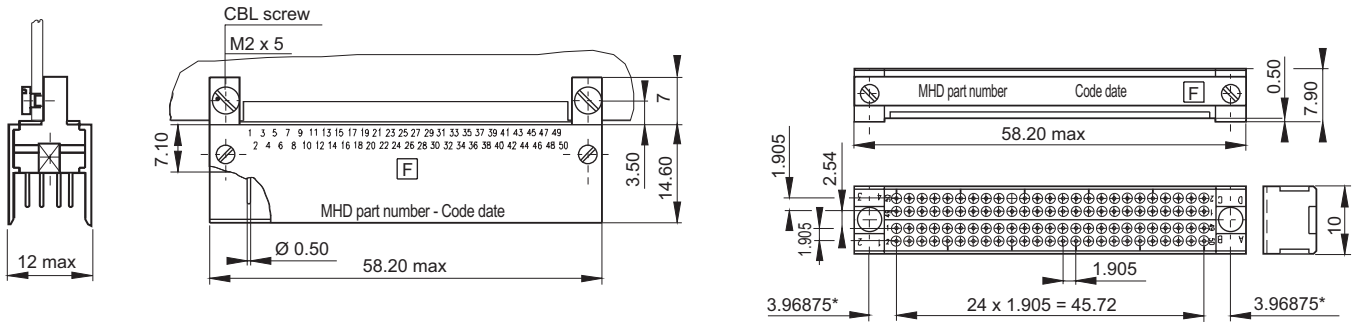

View mating side

5HA

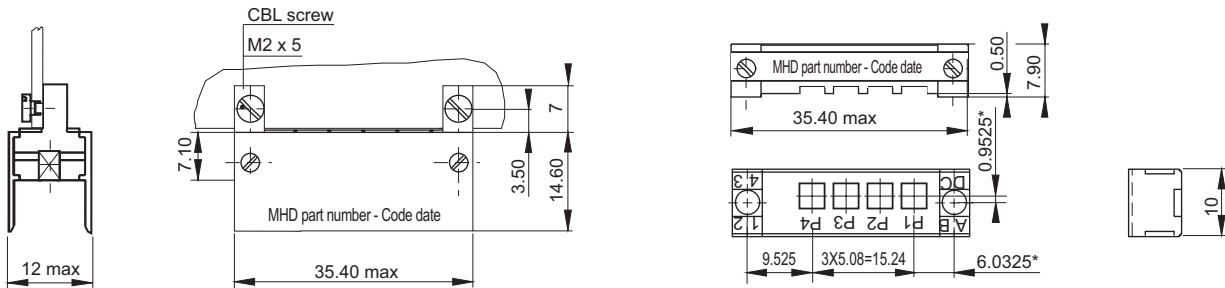

View mating side

1HB

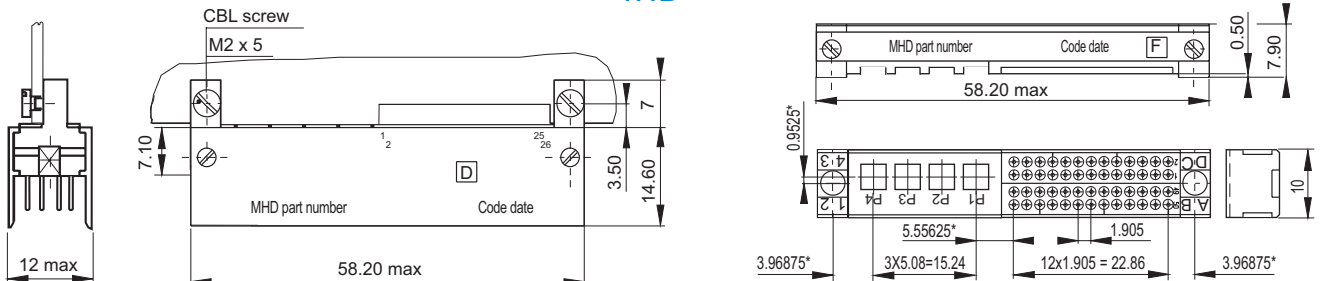

View mating side

* Theoretical dimensions.

The termination side contact configurations are specified on board preparation details

152 Contacts

Plug

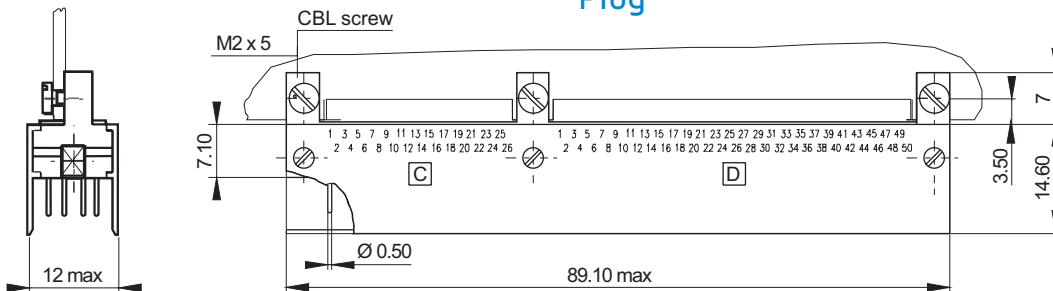

Receptacle

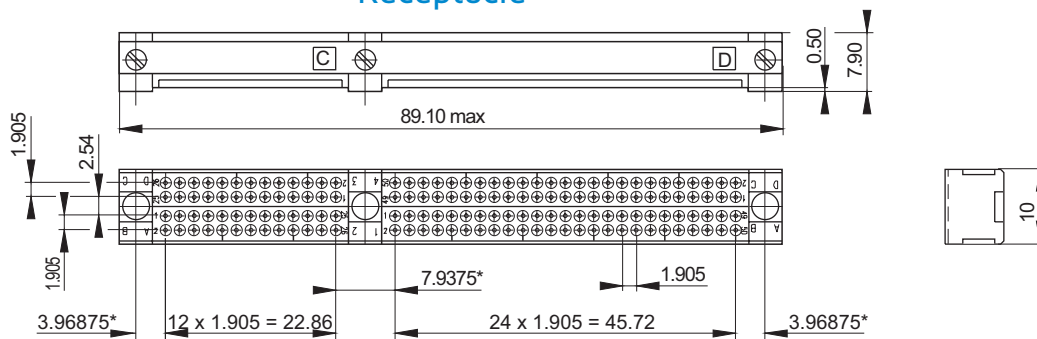

View mating side

6XA

Plug

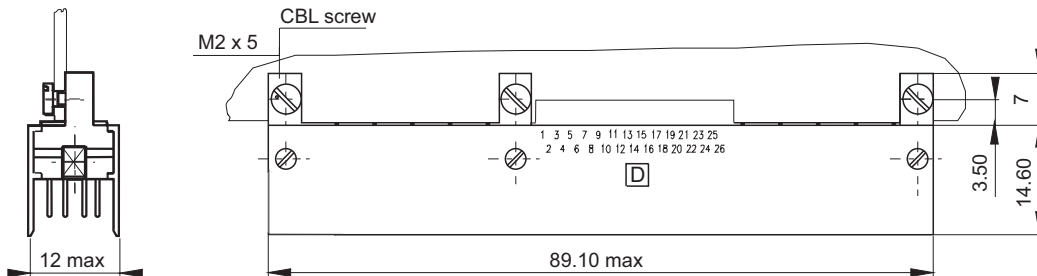

Receptacle

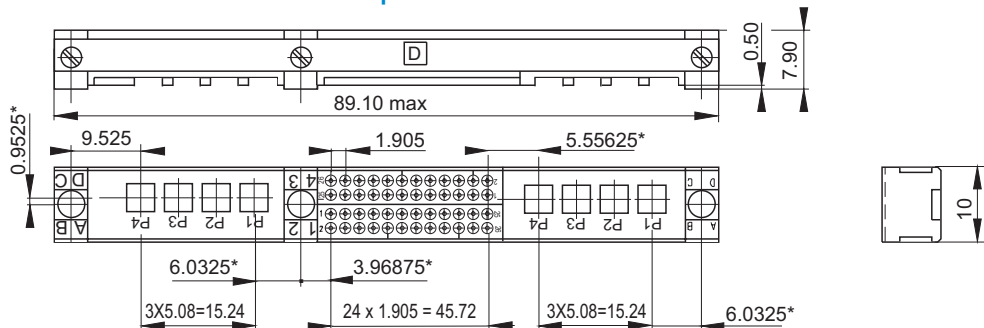

View mating side

* Theoretical dimensions.
The termination side contact configurations are specified on board preparation details.

200 Contacts Plug

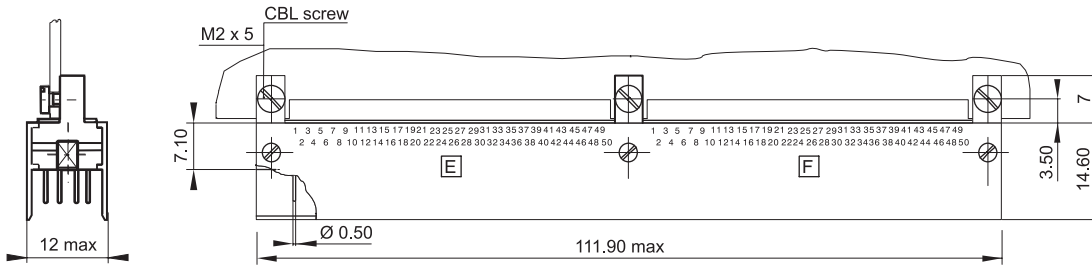

Receptacle

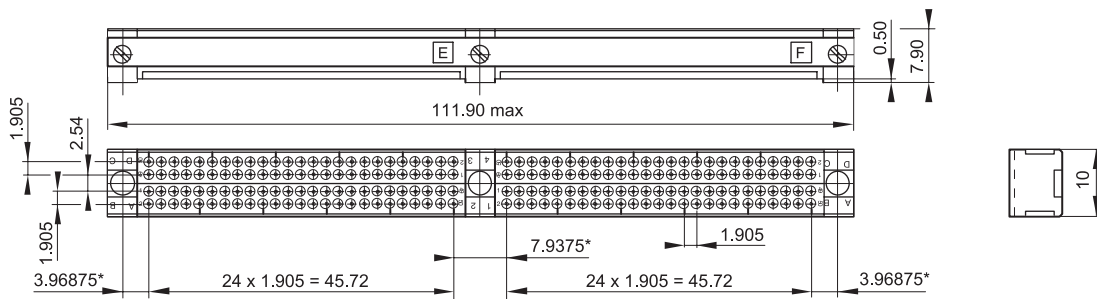

View mating side

2XA Plug

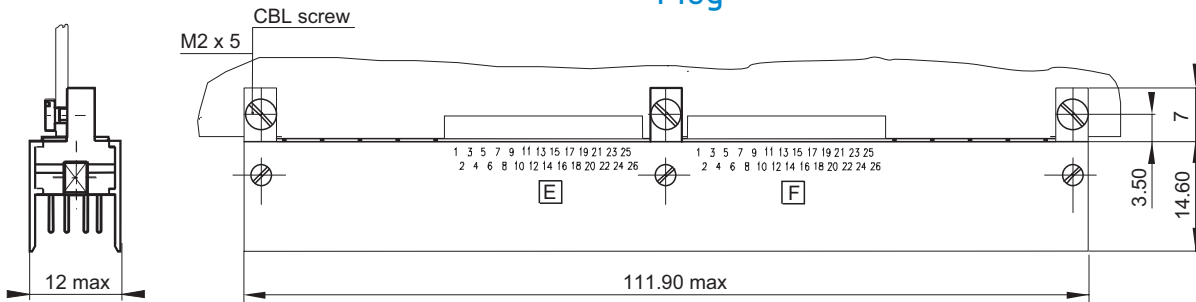

Receptacle

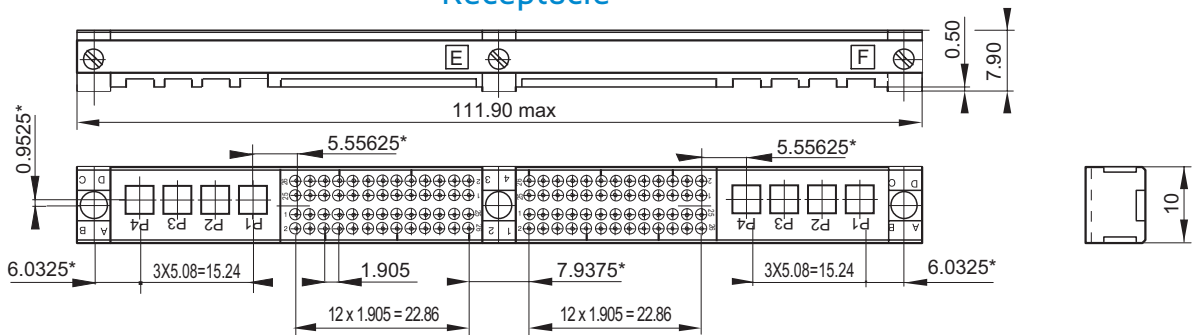

View mating side

* Theoretical dimensions.

The termination side contact configurations are specified on board preparation details

252 Contacts Plug

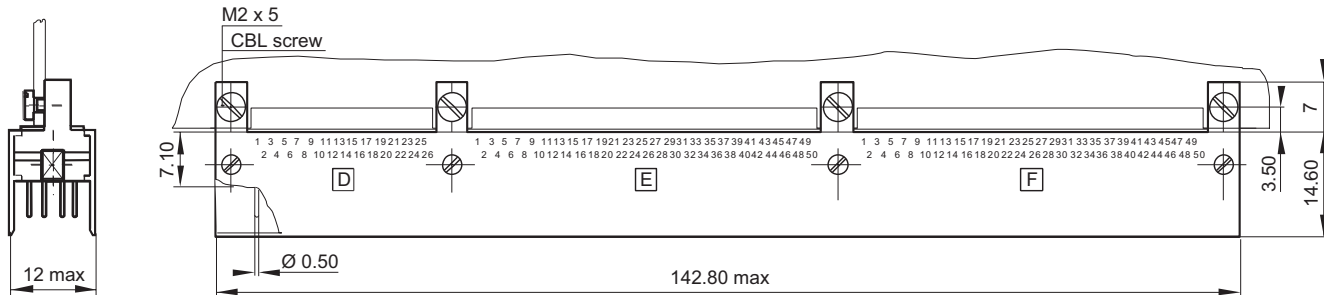

Receptacle

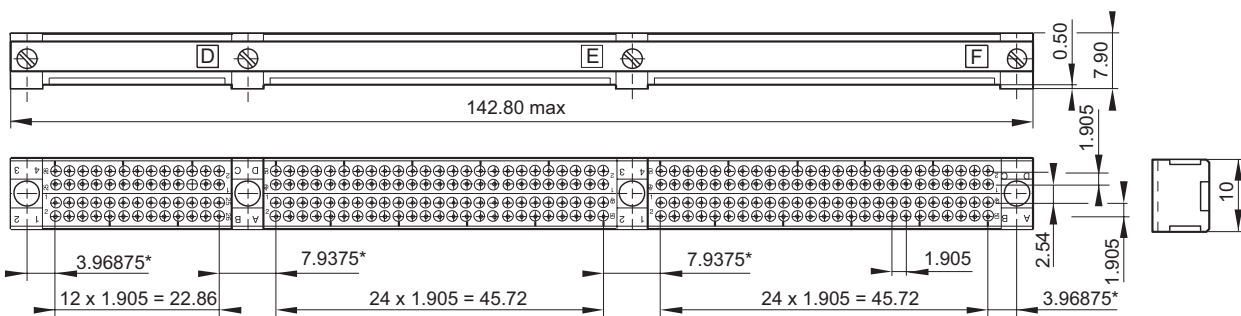

View mating side

7XB Plug

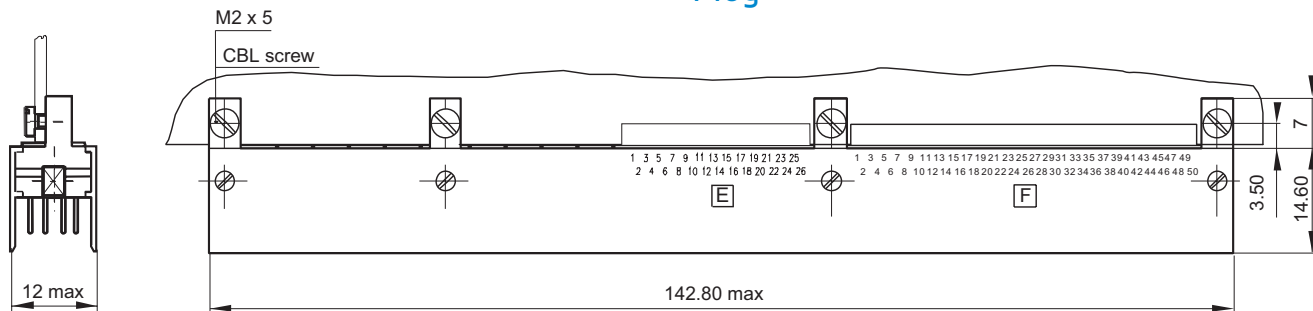

Receptacle

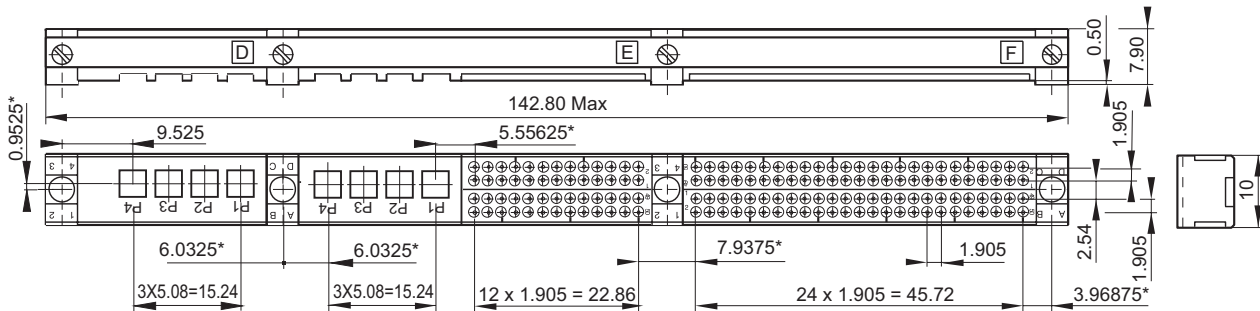

View mating side

* Theoretical dimensions.

The termination side contact configurations are specified on board preparation details.

300 Contacts Plug

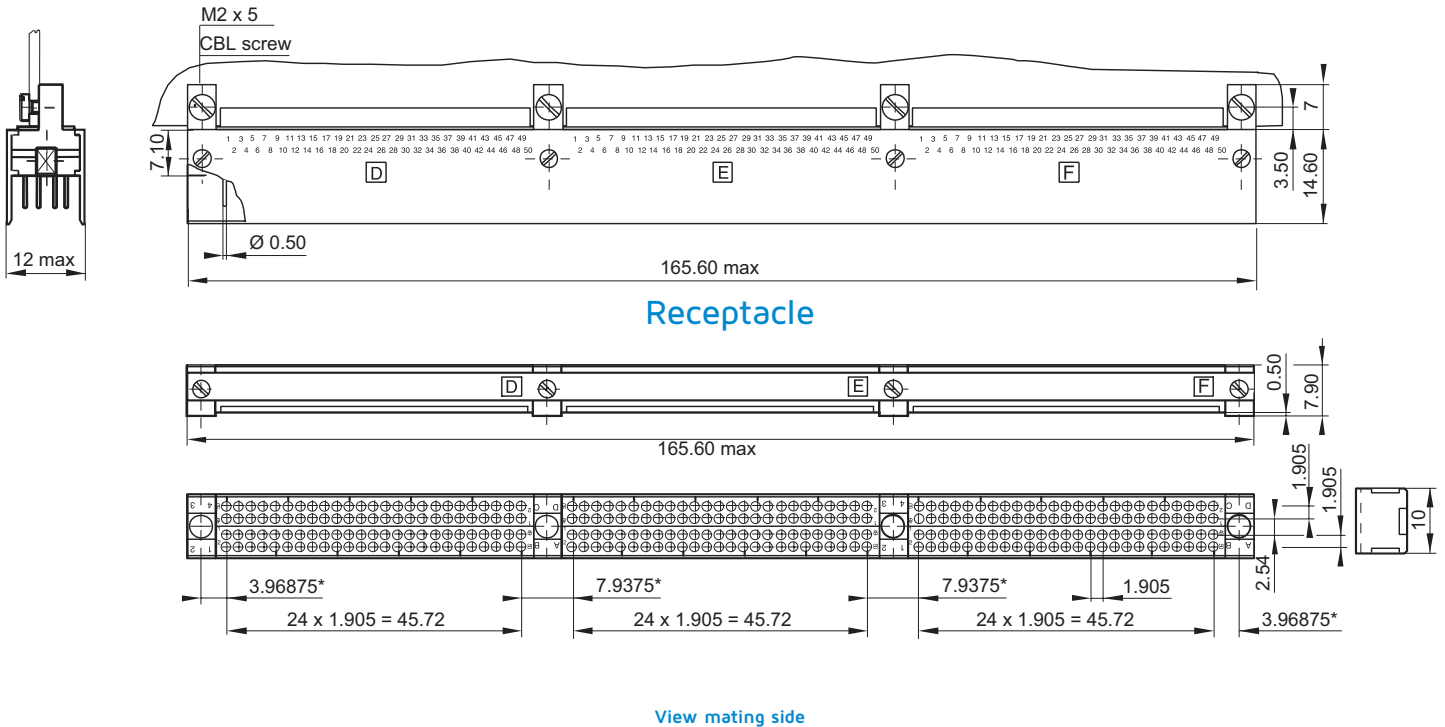

3HB Plug

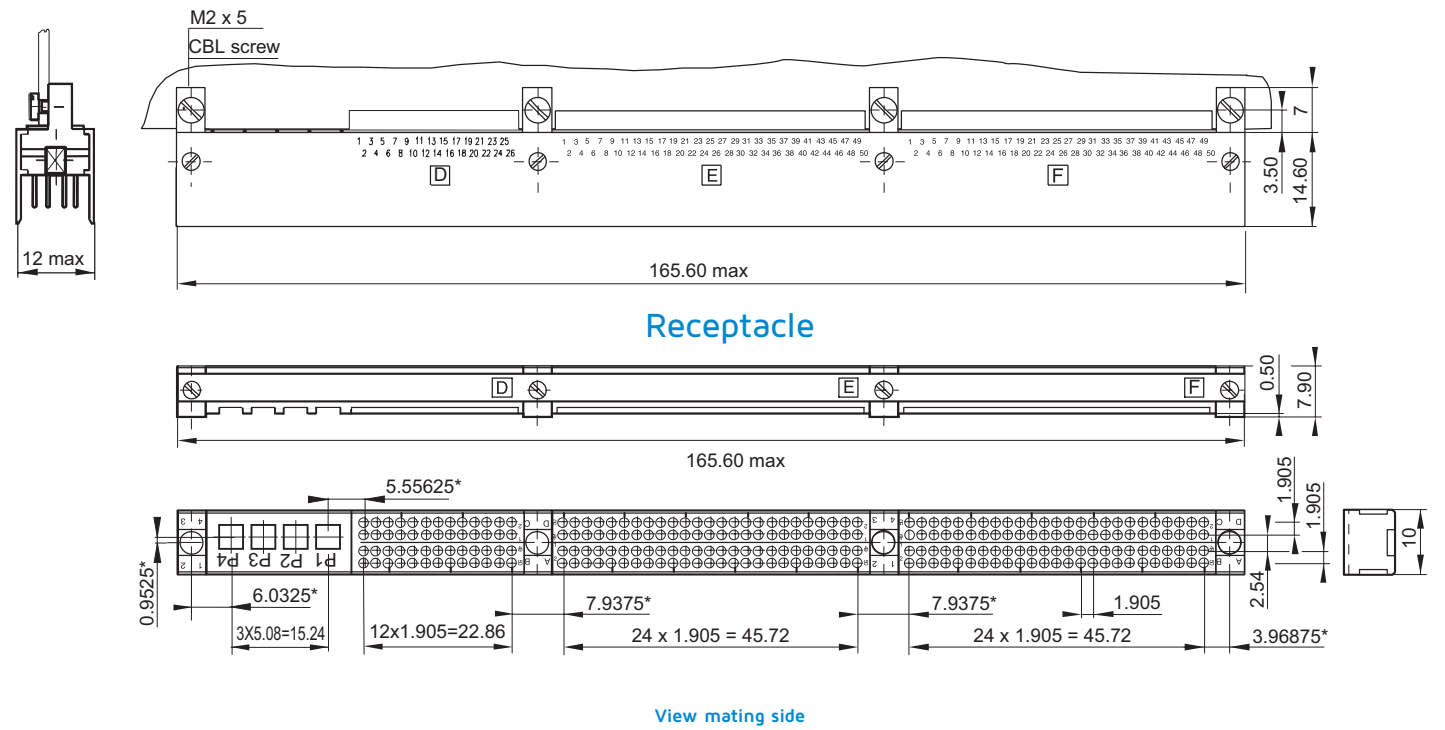

* Theoretical dimensions.
The termination side contact configurations are specified on board preparation details.

352 Contacts

Plug

Receptacle

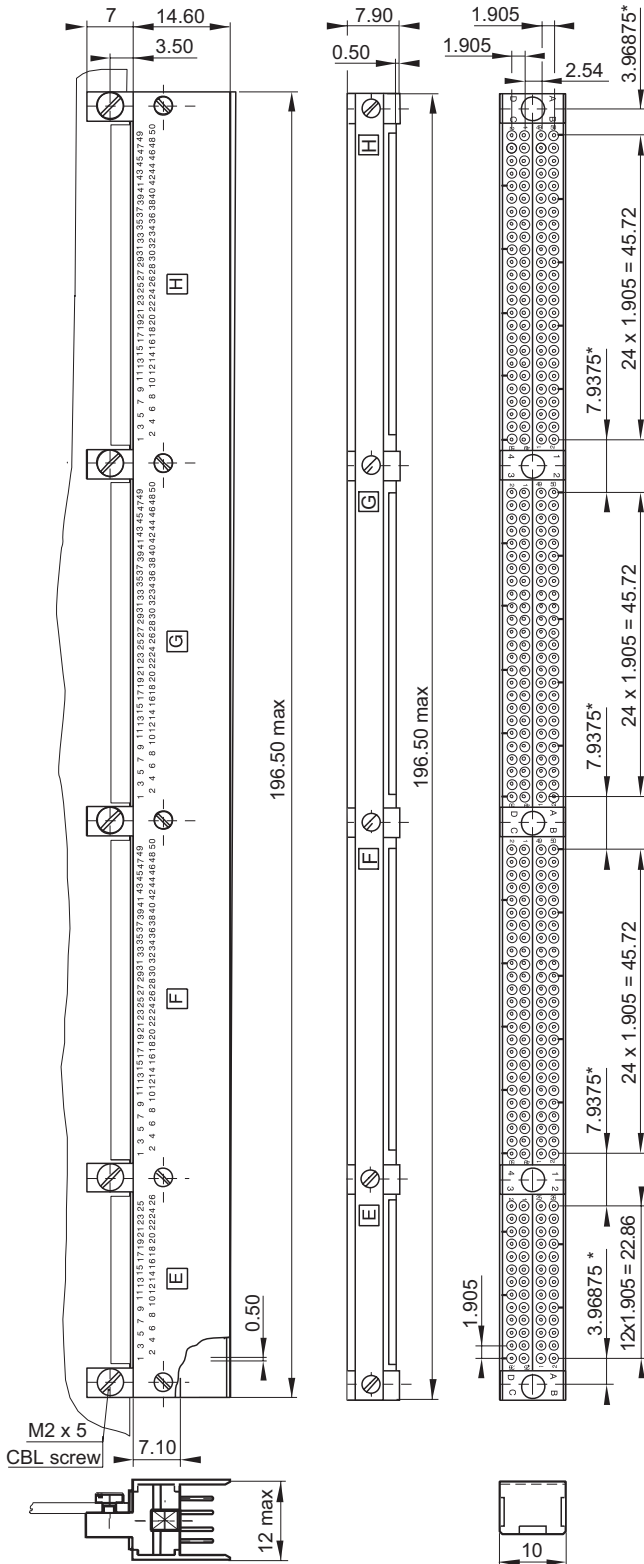

400 Contacts

Plug

Receptacle

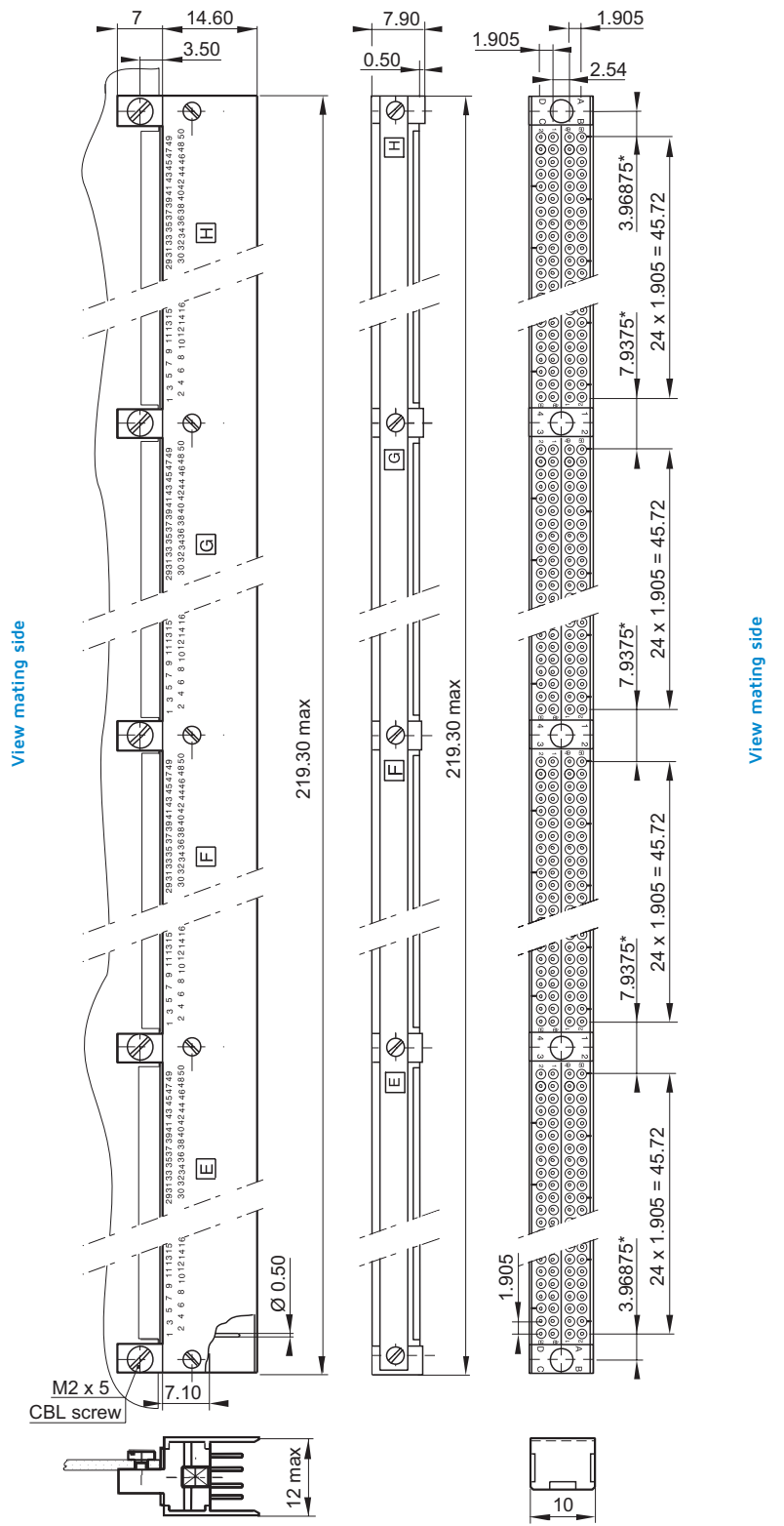

View mating side

View mating side

* Theoretical dimensions.
The termination side contact configurations are specified on board preparation details.

Guiding Devices

Receptacle

MHD 00- __ 121

Polarised female guide vertical mounting (Length: 5.50)

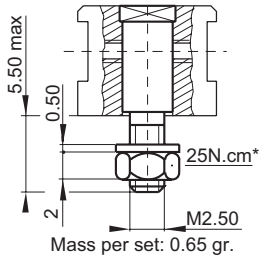

Mass per set: 0.65 gr.

MHD 00- __ Z122

Polarised female guide vertical mounting (Length: 7)

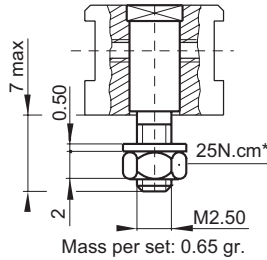

Mass per set: 0.65 gr.

MHD 00- __ z124 / Z134

Polarised female guide transverse mounting P/N 124: A=6; 134: A=6.60

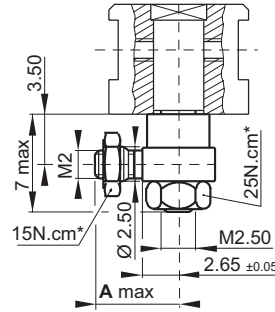

Mass per set: 1.50 gr. (P/N:124)

MHD 00- __ Z126

Unpolarised female guide vertical mounting

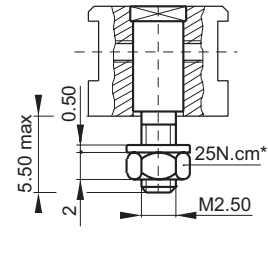

MHD 00- __ Z130

All polarity female guide vertical mounting (Length: 5.50)

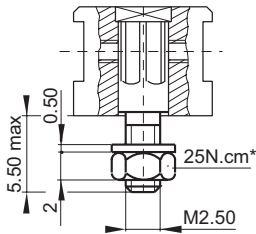

MHD 00- __ Z131

All polarity female guide vertical mounting (Length: 7)

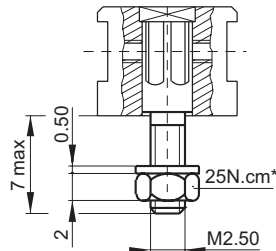

MHD 00- __ Z133

All polarity female guide transverse mounting

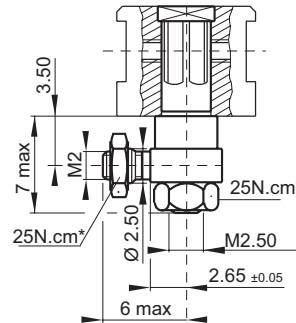

MHD 00- __ Z190

Ground female guide vertical mounting

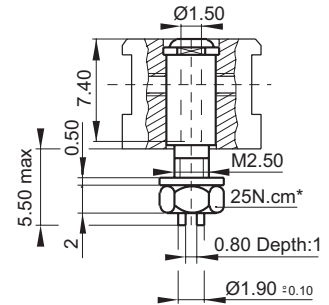

Plug

MHD 00- __ 110

Polarized male guide transverse mounting

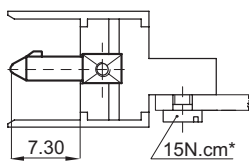

Mass per set: 0.55 gr.

MHD 00- __ Z111

Polarized male guide vertical mounting

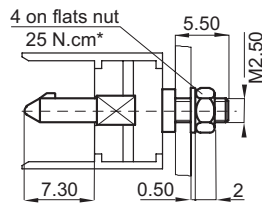

Mass per set: 1.35 gr.

MHD 00- __ Z125

Unpolarized male guide transverse mounting

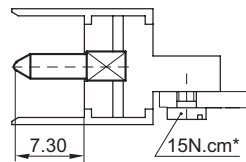

Mass per st: 0.55 gr.

MHD 00- __ Z191

Ground male contact transverse mounting

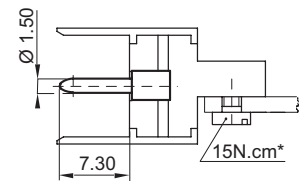

* Theoretical dimensions.

The termination side contact configurations are specified on board preparation details.

Contact Board Preparation Details

52 Contact Board Preparation Details⁽¹⁾

Receptacle

Straight Termination

Guides: 121, 122, 126, 130, 131, 190

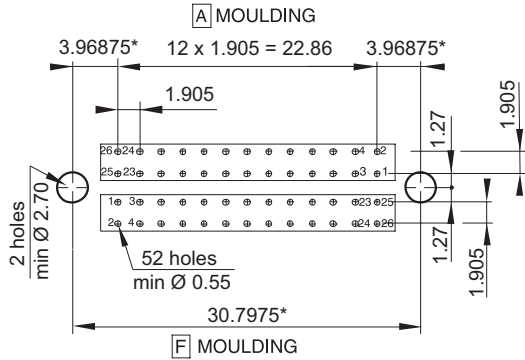

90° Termination

Guides: 124, 133, 134

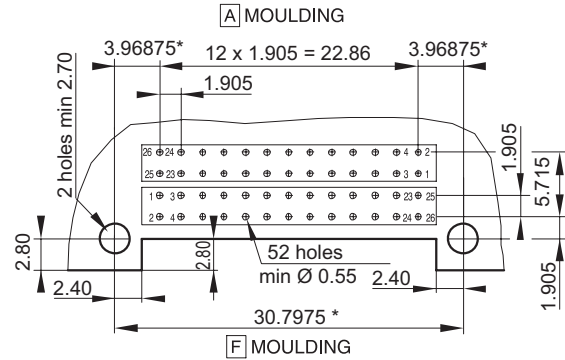

Plug

Straight Termination

Guides: 111

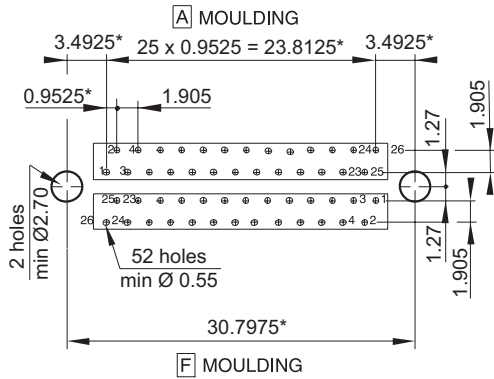

90° Termination

Guides: 110, 125, 191

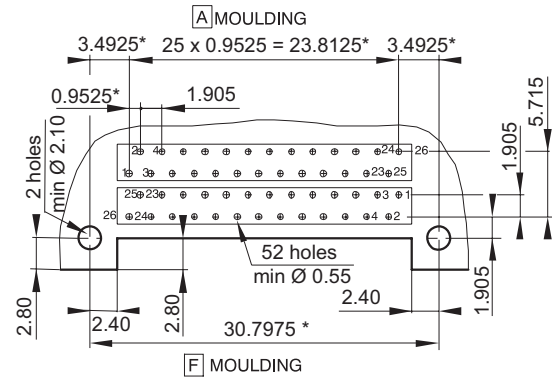

Surface mount termination

Guides: 110, 125, 191

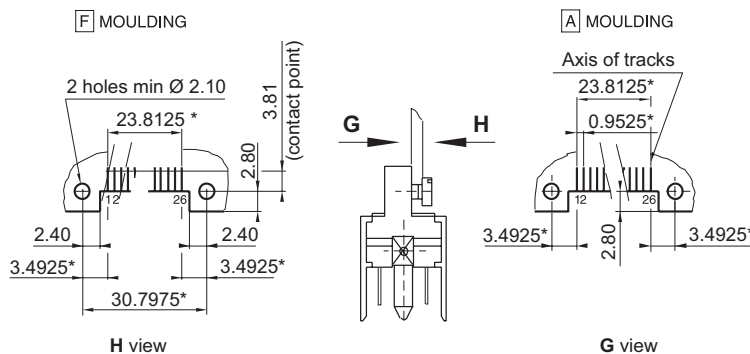

(1) Note: See important note on 1HB preparation board details (page 18).

* Theoretical dimensions.

5HA Contact Board Preparation Details ⁽¹⁾

Receptacle

Straight Termination

Guides: 121, 122, 126, 130, 131, 190

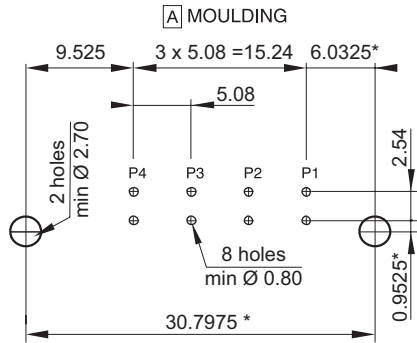

90° Termination

Guides: 124, 133, 134

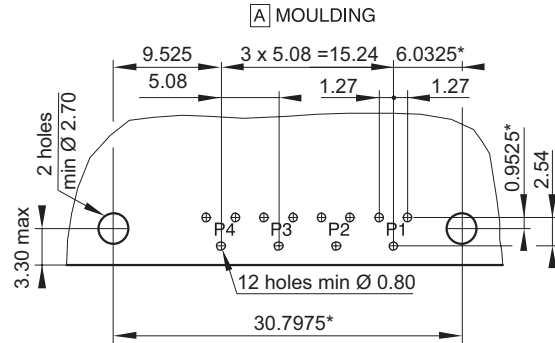

Plug

90° Termination

Guides: 110, 125, 191

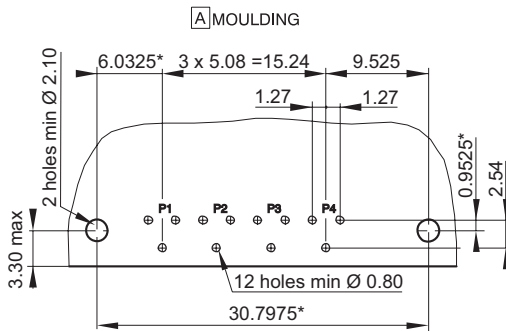

Surface mount termination

Guides: 110, 125, 191

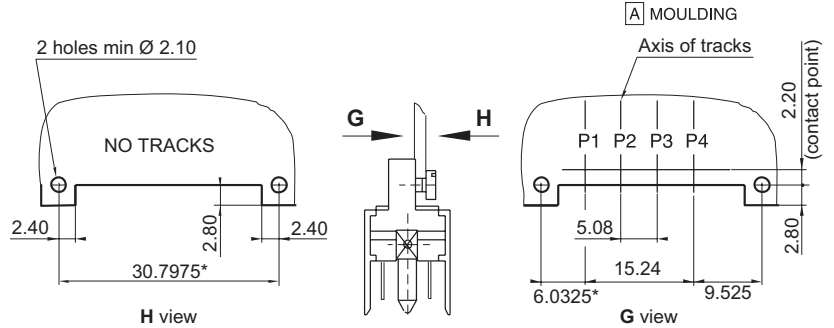

(1) Note: See important note on 1HB preparation board details (page 18).

* Theoretical dimensions.

100 Contact Board Preparation Details ⁽¹⁾

Receptacle

Straight termination

Guides: 121, 122, 126, 130, 131, 190

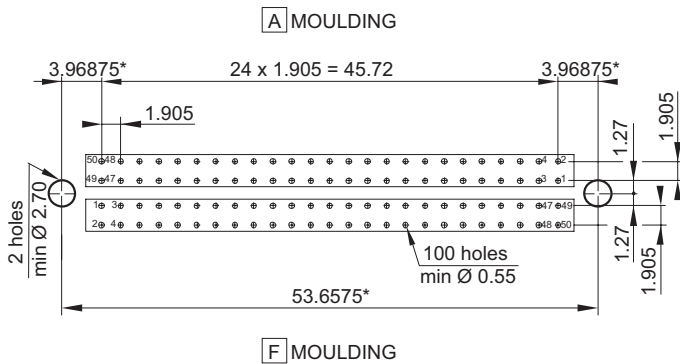

90° Termination

Guides: 124, 133, 134

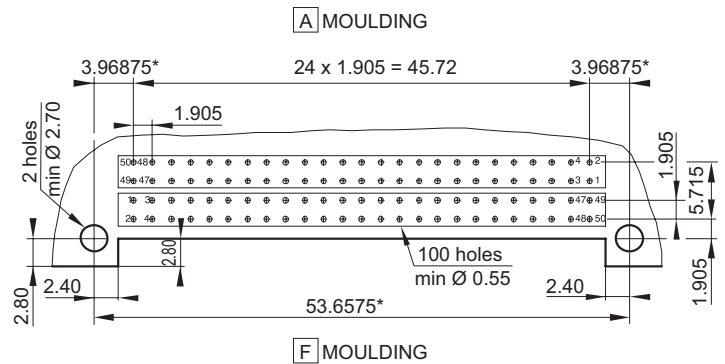

Plug

Straight termination

Guides: 111

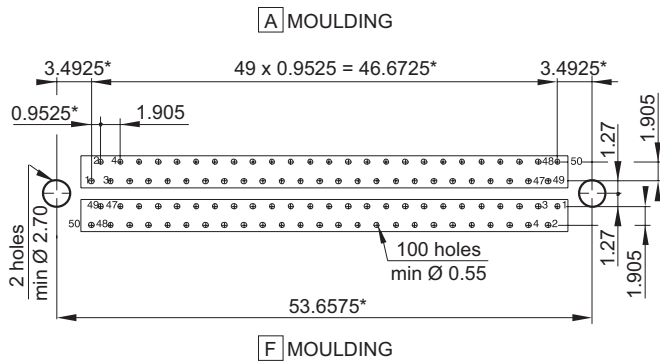

90° Termination

Guides: 110, 125, 191

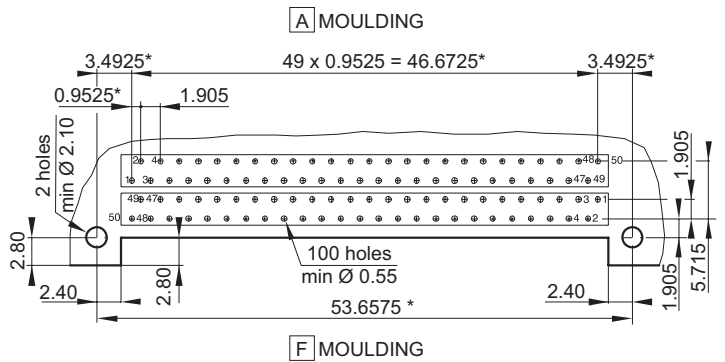

Surface mount termination

Guides: 110, 125, 191

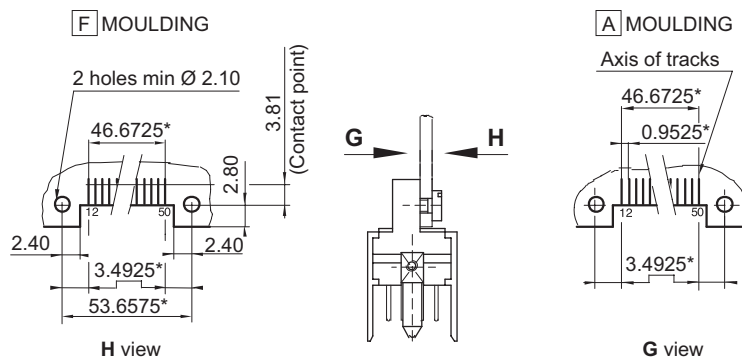

(1) Note: See important note on 1HB preparation board details (page 18).

* Theoretical dimensions.

1HB Contact Board Preparation Details ⁽¹⁾

Receptacle

Straight termination

Guides: 121, 122, 126, 130, 131, 190

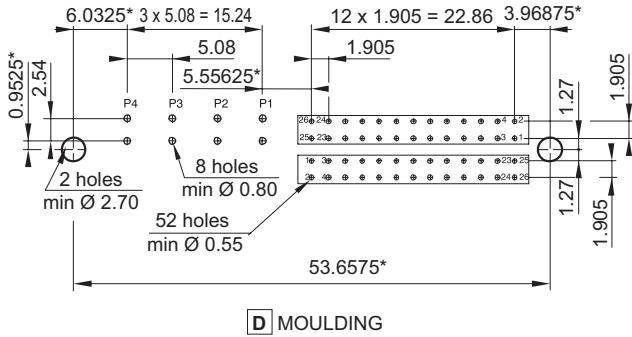

90° Termination

Guides: 124, 133, 134

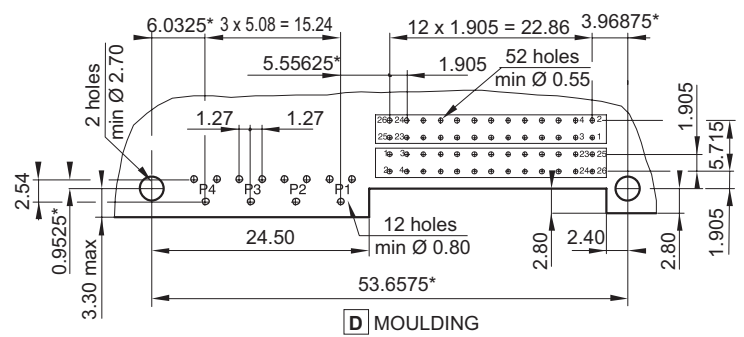

Plug

90° Termination

Guides: 110, 125, 191

A MOULDING

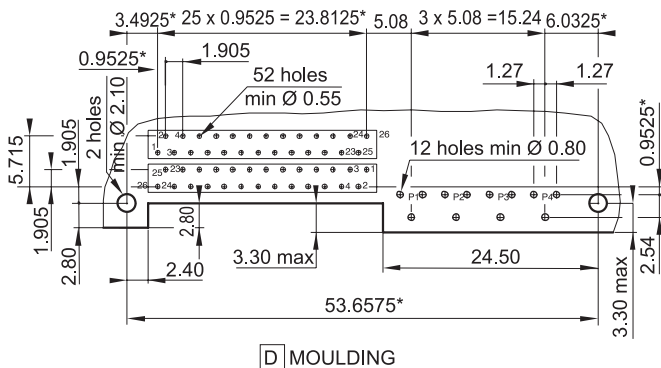

Surface mount termination

Guides: 110, 125, 191

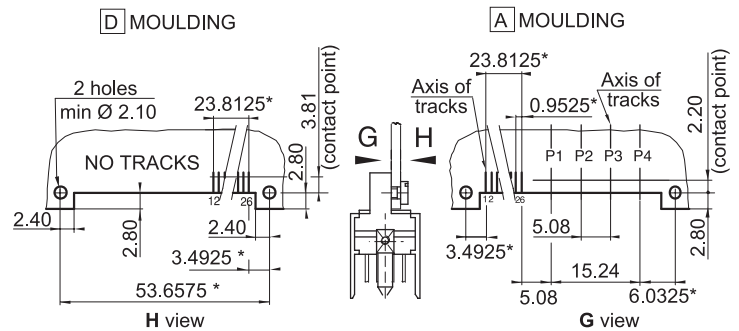

(1) Note: See important note on 1HB preparation board details (page 18).

* Theoretical dimensions.

152 Contact Board Preparation Details⁽¹⁾

Plug

Straight termination

Guides: 112

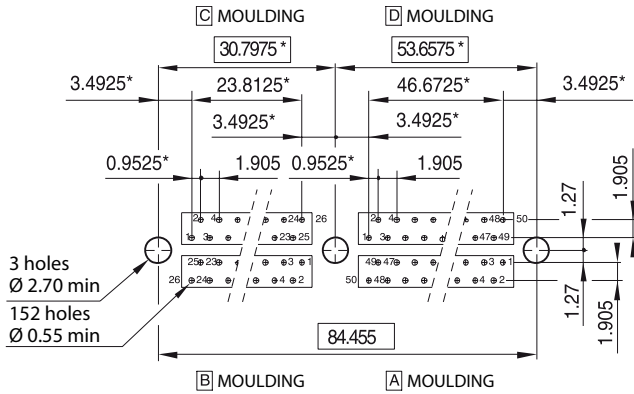

90° Termination

Guides: 110, 125, 191

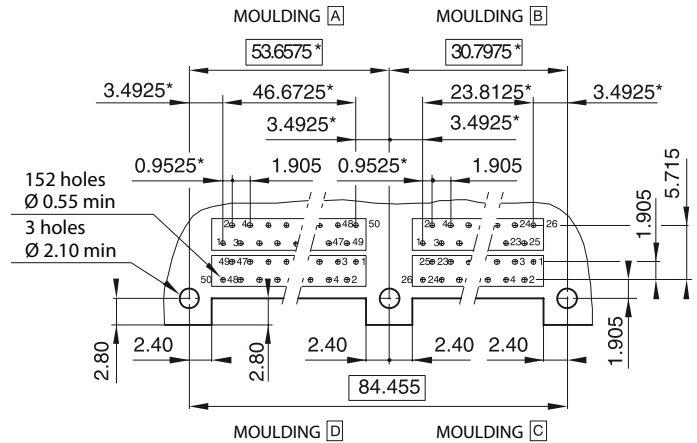

Receptables

Straight termination

Guides: 121,122,126,130,131,190

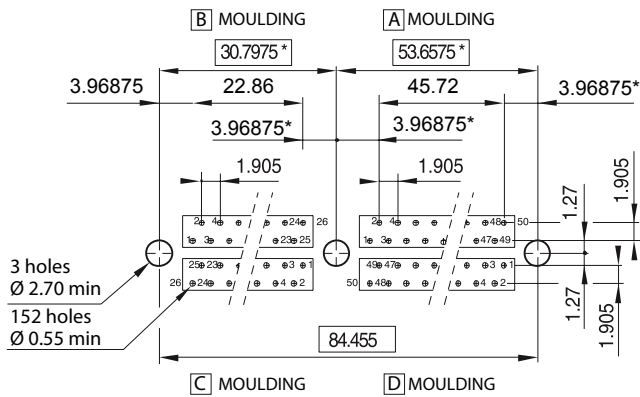

90° Termination

Guides: 124, 133, 134

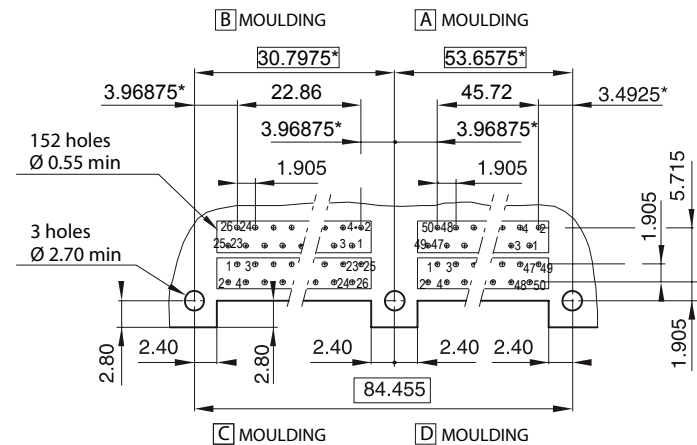

1. Important note

Drilling layouts shown concern the following full configurations: 052, 5HA, 100, 1HB, 200. Other arrangements, shown on "MODULES CONFIGURATION" page, require a specific drilling layout to ensure the correct mounting of the chosen connector, that you must obtain from our technical department. However, the drilling layouts shown above should help you to achieve the desired configuration. For that, you may have to mix those drilling layouts to obtain the right configuration.

Power & High Frequency Contacts (NFC 93569)

Example of Contact Overview (020 084 2- 10 RG1)

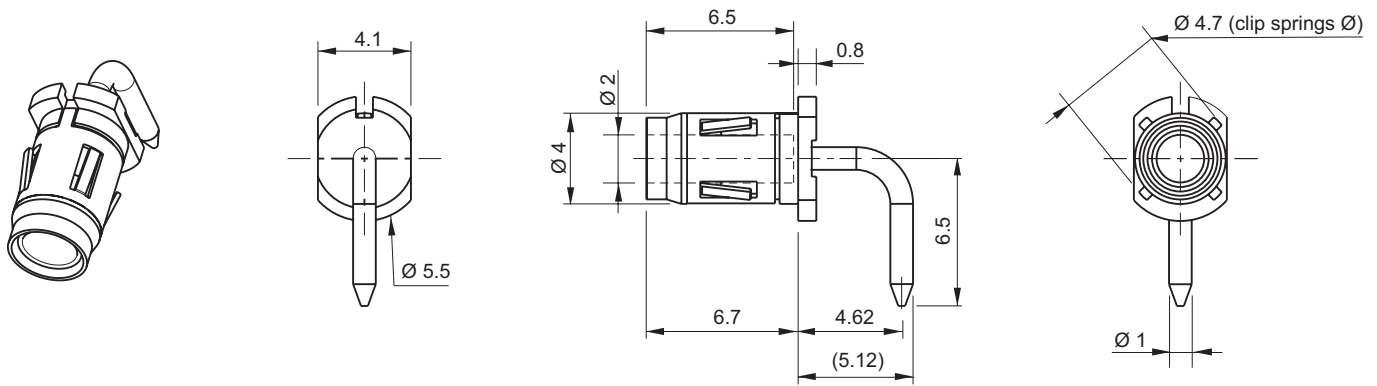

Power Contacts

Male	P/N
90° termination	020 085 1- 10R OG
Straight termination	020 087 1- 30R OG
Solder bucket termination	020 091 1- 40R OG

Female	P/N
90° termination	020 084 2- 10R G1
Straight termination	020 056 2- 30R G1
Solder bucket termination	020 060 2- 40R G1

High Frequency Contacts

	Male P/N	Female P/N
Vertical mounting, suitable for flexible cable Ø 1.9 max. Ref. KX 21 A (Rg 178 B/U or RG 196).	KMX 3-M 081	KMX 3-f 081
Transverse mounting, suitable for flexible cable Ø 1.9 max. Ref. KX 21 A (Rg 178 B/U or RG 196). Usable with mother board, thickness 3.2 mm max.	KMX 3-M 092	KMX 3-F 092
Vertical mounting, suitable for flexible cable Ø 2.5 max. Ref. KX 22 A (RG 316).	KMX 3-M 101	KMX 3-F 101
Transverse mounting, suitable for flexible cable Ø 2.5 max. Ref. KX 22 A (RG 316). Usable with mother board, thickness 3.2 mm max.	KMX 3-M 112	KMX 3-F 112
Vertical mounting, suitable to semi-rigid cable Ø 2.2 max. Ref. Ks 1 A (RG 405 - UT 85).	KMX 3-M 131	KMX 3-F 131
Transverse mounting, suitable to semi-rigid cable Ø 2.2 max. Ref. Ks 1 A (RG 405 - UT 85). Usable with mother board, thickness 3.2 mm max.	KMX 3-M 142	KMX 3-F 142
Straight termination tail for direct mounting on to PCB	KMX 3-m 041	KMX 3-f 041
90° termination tail for direct mounting on to PCB	KMX 3-m 032	KMX 3-f 032
SMT termination	KMX 3-m 172	KMX 3-f 172

Extraction Tools

P/N: SD- 030 00 CX 003

Technical Characteristics

Materials & Platings

Insulator	Diallyl Phtalate UL94V0
Frame	Aluminum Alloy
Contact	Copper Alloy
Guide	Brass + Ni plating or Stainless Steel
Contact plating	Ni + Au

Environmental

Temperature range	-55° C to 125° C
Safety of contact from extraction	Statical 2 mm / 0.079 in. Dynamical 1.80 mm / 0.071 in.
Mating cycles	5000
Withdrawal forces	≤0.5 N
Special contacts	According to NFC 93569

Electrical

Contact resistance	Signal ≤12 mΩ
Current rating	Signal 3 A
Insulation	>104 MΩ
Voltage rating	200 V
Proof voltage	800 V
Contact diameter	Signal 0.50 mm

How To Order



1



2



3



4



5

1 Series				
2 Arrangement	1 0 0	2 0 0		
3 Part - Polarity Plating	1 5	Male plug - MIL plating	2 4	Female receptacle - MIL plating
	1 9	Male plug - MIL tinned plating	2 8	Female receptacle - MIL tinned plating
4 Termination Styles	1 0	90° termination, PCB thickness 1.60	1 1	90° termination, PCB thickness 2.40
	3 0	Straight termination, PCB thickness 2.40	3 1	Straight termination, PCB thickness 3.20
	4 4	SMT* - Uncentered PCB thickness 3.80	9 6	Straight termination, PCB thickness 4.50
5 Guide Styles	1 1 0	Male polarized, transverse mount, standard plug	1 1 1	Male polarized, vertical mount
	1 2 1	Female polarized, vertical mount	1 2 2	Female polarized, vertical mount
	1 2 4	Female polarized, transverse mount	1 2 5	Male unpolarized, transverse mount
	1 2 6	Female unpolarized, vertical mount	1 3 0	Female all polarized, vertical mount
	1 3 1	Female all polarized, vertical mount	1 3 3	Female all polarized, transverse mount
	1 3 4	Female polarized, transverse mount	1 9 0	Female power or mass contact, vertical mount
	1 9 1	Male power or mass contact, transverse mount	2 0 1	¼ turn, free connector

* Surface Mount Termination
PCB thickness is in mm

Modules Configuration

Receptacle - Mating Side Views Single arrangements

50 ways module

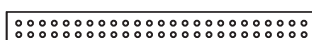

100 ways module

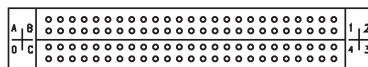

200 ways module

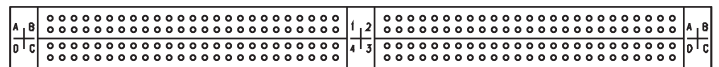

Standard Plugging Stages

Misalignment

Longitudinal

Lateral

Gap

Lateral

Tilting

Longitudinal

Lateral

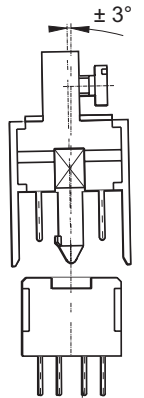
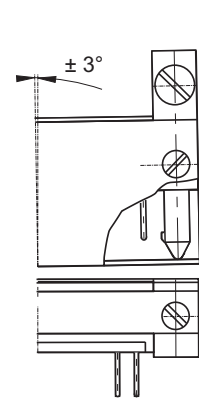
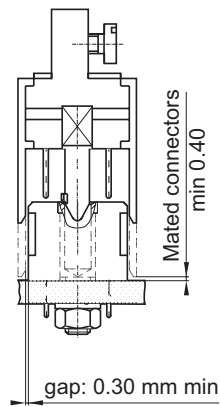
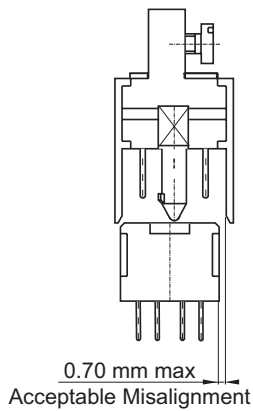
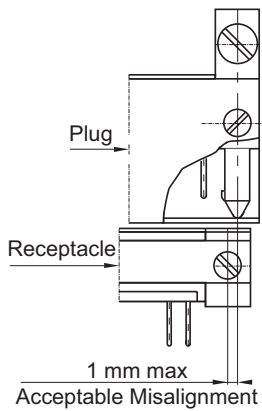

Mounting Examples

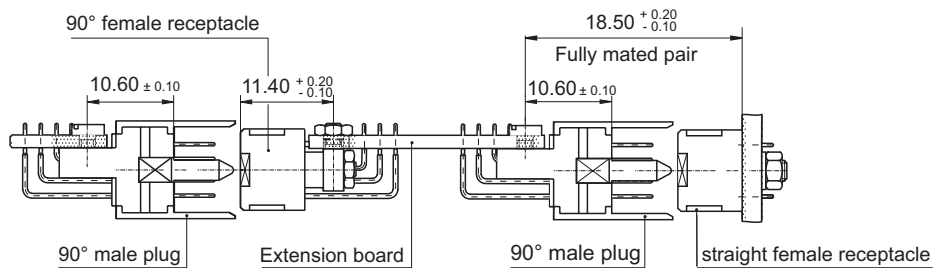
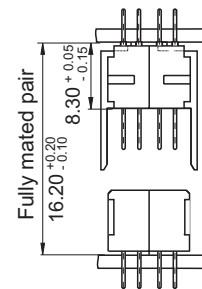
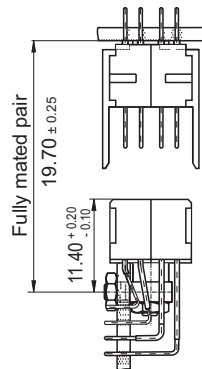
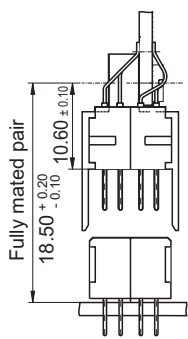

Displacement

Max displacement allowed while plugging in the receptacle: 0.15 mm in all plugged in connector ways.

Termination Styles

Receptacle

Through board solder - 90°

Ref: 10
PCB: 1.44 - 1.76
A = $3.25^{+0.15}_{-0.45}$
B = 6 max

Ref: 11
PCB: 1.98 - 2.42
A = $3.85^{+0.15}_{-0.45}$
B = 6.60 max

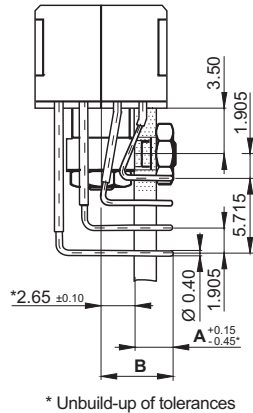

Through board solder - Straight

Ref: 30
PCB: 2.16 - 2.64
A = 3.50 min
4.00 max

Ref: 31
PCB: 2.88 - 5.50
A = 6.10 min
6.60 max

Ref: 96
PCB: 3.42 - 4.18
A = 4.70 min
5.10 max

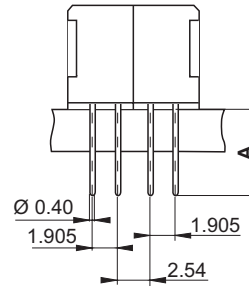

Plug

Through board solder - 90°

Ref: 10
PCB: 1.44 - 1.76
A = 5.95 max

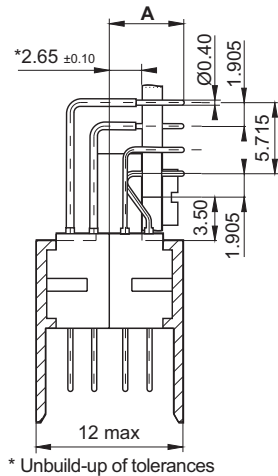

Through board solder - Straight

Ref: 30
PCB: 2.16 - 2.64
A = 3.50 min
4.00 max

Ref: 31
PCB: 2.88 - 3.52
A = 4.60 min
5.10 max

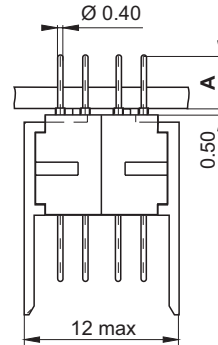

Surface Mount (uncentered PCB)

Ref: 44
PCB: 3.60 - 4.00
A = 4.40 max

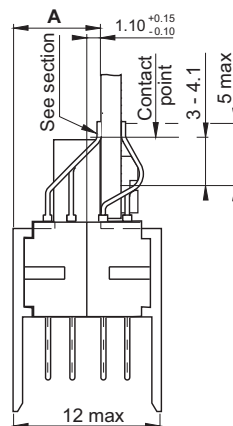

Connector Dimensions

100 Contacts

Plug

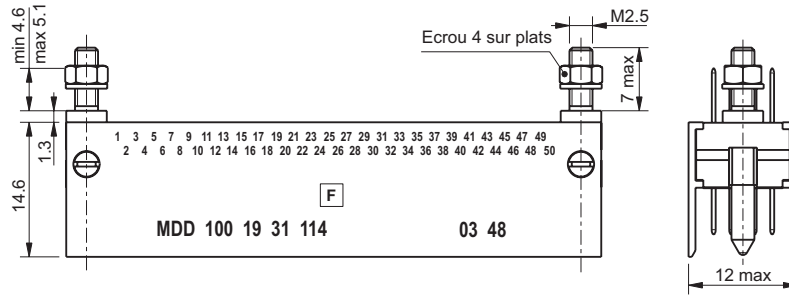

Receptacle

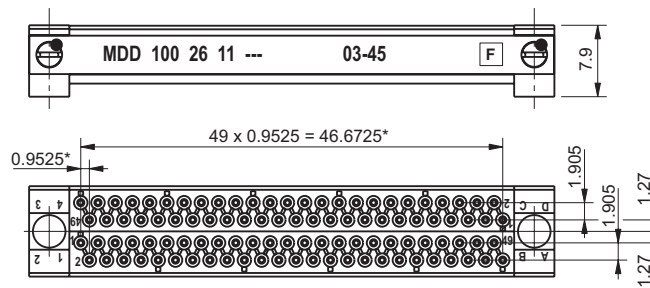

200 Contacts

Plug

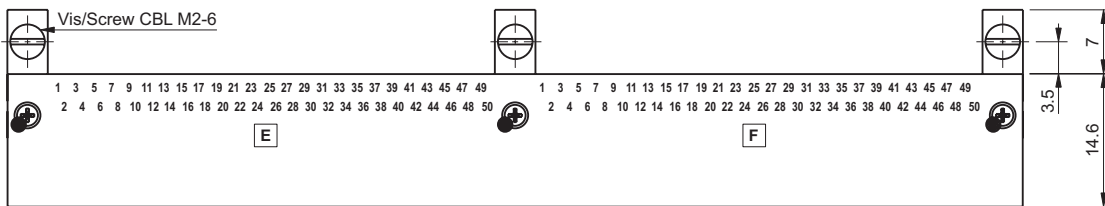

Receptacle

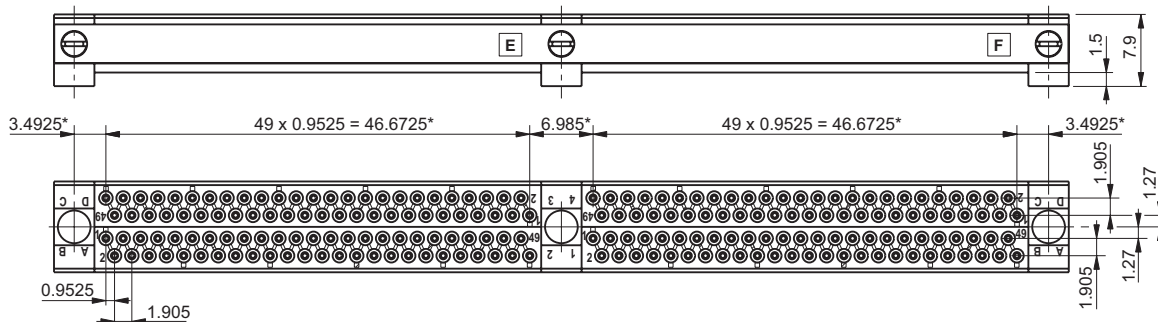

* Theoretical dimensions.

Guiding Devices

Receptacle

MHD 00- __ 121

Polarized female guide vertical mounting (Length: 5.50)

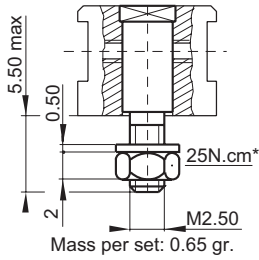

MHD 00- __ Z122

Polarized female guide vertical mounting (Length: 7)

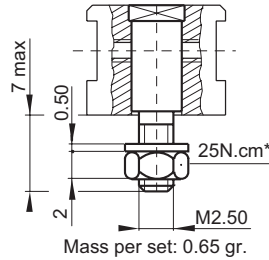

MHD 00- __ z124 / Z134

Polarized female guide transverse mounting P/N 124: A=6; 134: A=6.60

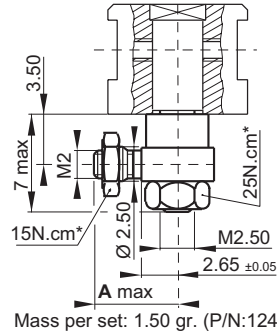

MHD 00- __ Z126

Unpolarized female guide vertical mounting

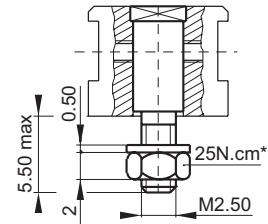

MHD 00- __ Z130

All polarity female guide vertical mounting (Length: 5.50)

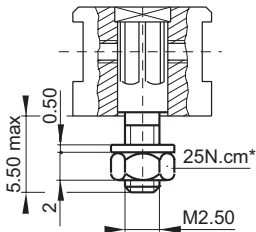

MHD 00- __ Z131

All polarity female guide vertical mounting (Length: 7)

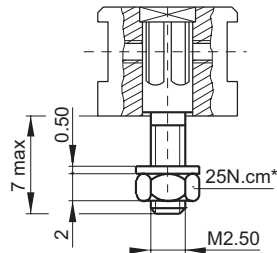

MHD 00- __ Z133

All polarity female guide transverse mounting

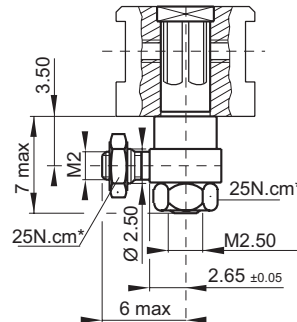

MHD 00- __ Z190

Ground female guide vertical mounting

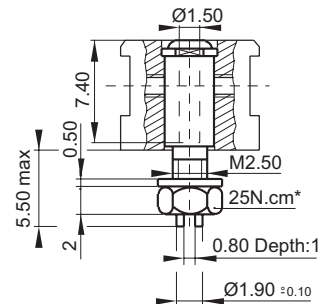

Plug

MHD 00- __ 110

Polarized male guide transverse mounting

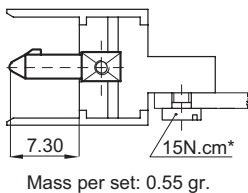

MHD 00- __ Z111

Polarized male guide vertical mounting

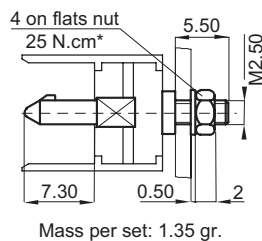

MHD 00- __ Z125

Unpolarized male guide transverse mounting

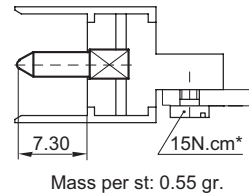

MHD 00- __ Z191

Ground male contact transverse mounting

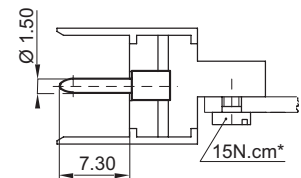

* Theoretical dimensions.

Contact Board Preparation Details

100 Contact Board Preparation Details⁽¹⁾

Receptacle

Straight termination

Guides: 121, 122, 126, 130, 131, 190

[A] MOULDING

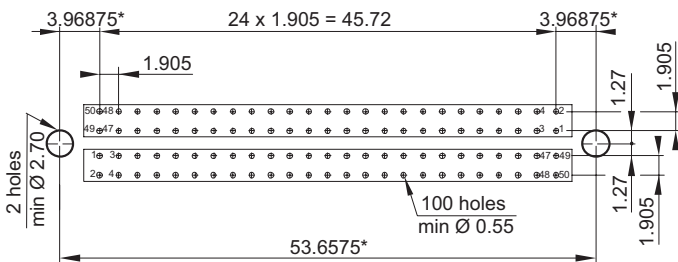

[F] MOULDING

90° Termination

Guides: 124, 133, 134

[A] MOULDING

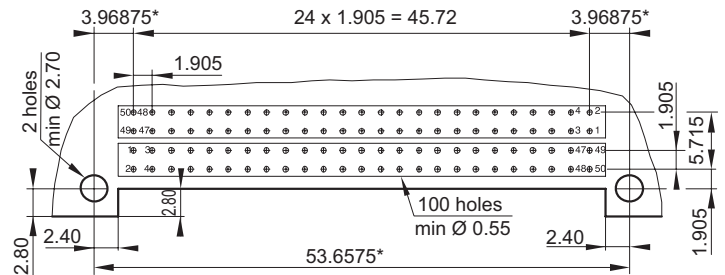

[F] MOULDING

Plug

Straight termination

Guides: 111

[A] MOULDING

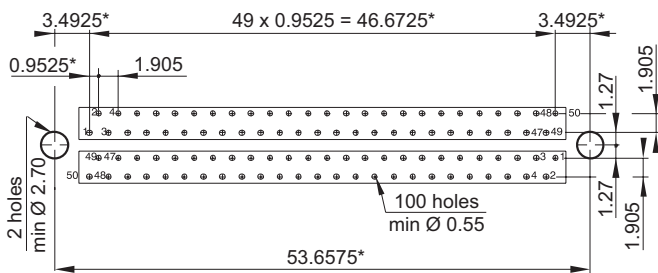

[F] MOULDING

90° Termination

Guides: 110, 125, 191

[A] MOULDING

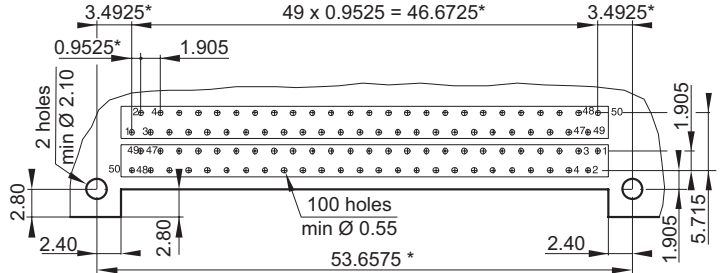

[F] MOULDING

Surface mount termination

Guides: 110, 125, 191

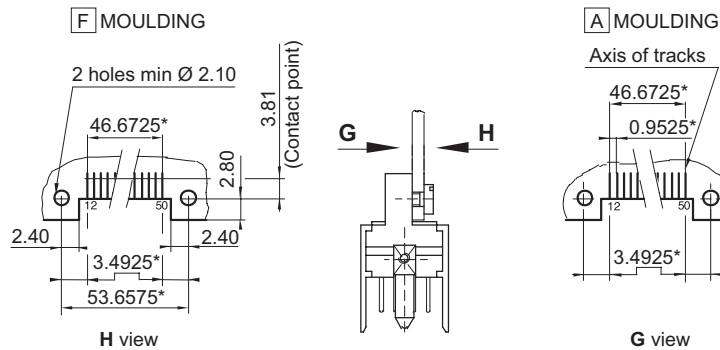

(1) Note: See important note on 1HB preparation board details (page 18).

* Theoretical dimensions.

Technical Characteristics

Materials & Platings

Insulator	LCP Thermoplastic
Contact	Copper Alloy
Guide	Brass + Ni plating or Stainless Steel
Contact plating	Ni + Au

Environmental

Temperature range	-55° C to 125° C
Safety of contact from extraction	Statical 2 mm / 0.079 in. Dynamical 1.80 mm / 0.071 in.
Mating cycles	5000
Withdrawal forces	≤0.5 N
Special contacts	According to NFC 93569

Electrical

Contact resistance	Signal ≤12 mΩ
Current rating	Signal 3 A
Insulation	>104 MΩ
Voltage rating	200 V
Proof voltage	800 V
Contact diameter	Signal 0.50 mm

How To Order



MDP

1

2 0 0

2

3

3

4 4

4

1 1 4

5

1 Series									
2 Arrangement	2 0 0								
3 Part - Polarity Plating	<table border="0"> <tr> <td>1 9</td> <td>Male plug - MIL tinned plating</td> <td>2 8</td> <td>Female receptacle - MIL tinned plating</td> </tr> </table>	1 9	Male plug - MIL tinned plating	2 8	Female receptacle - MIL tinned plating				
1 9	Male plug - MIL tinned plating	2 8	Female receptacle - MIL tinned plating						
4 Termination Styles	<table border="0"> <tr> <td>1 0</td> <td>90° termination, PCB thickness 1.60</td> <td>4 4</td> <td>SMT* - Uncentered PCB thickness 3.80</td> </tr> <tr> <td>3 1</td> <td>Straight termination, PCB thickness 3.20</td> <td>9 6</td> <td>Straight termination, PCB thickness 4.50</td> </tr> </table>	1 0	90° termination, PCB thickness 1.60	4 4	SMT* - Uncentered PCB thickness 3.80	3 1	Straight termination, PCB thickness 3.20	9 6	Straight termination, PCB thickness 4.50
1 0	90° termination, PCB thickness 1.60	4 4	SMT* - Uncentered PCB thickness 3.80						
3 1	Straight termination, PCB thickness 3.20	9 6	Straight termination, PCB thickness 4.50						
5 Guide Styles	<table border="0"> <tr> <td>1 1 4</td> <td>Male unpolarized, vertical mount</td> <td>1 2 2</td> <td>Female polarized, vertical mount</td> </tr> <tr> <td>1 2 5</td> <td>Male unpolarized, transverse mount</td> <td>1 3 4</td> <td>Female polarized, transverse mount</td> </tr> </table>	1 1 4	Male unpolarized, vertical mount	1 2 2	Female polarized, vertical mount	1 2 5	Male unpolarized, transverse mount	1 3 4	Female polarized, transverse mount
1 1 4	Male unpolarized, vertical mount	1 2 2	Female polarized, vertical mount						
1 2 5	Male unpolarized, transverse mount	1 3 4	Female polarized, transverse mount						

* Surface Mount Termination
PCB thickness is in mm

Connector Dimensions

200 Contacts Plug

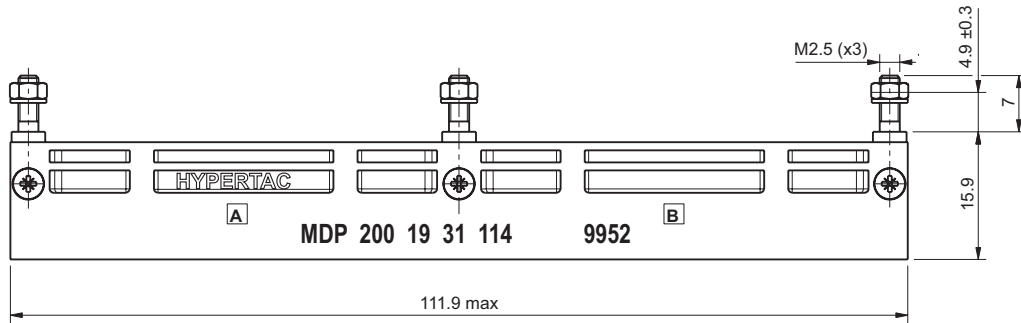

Receptacle

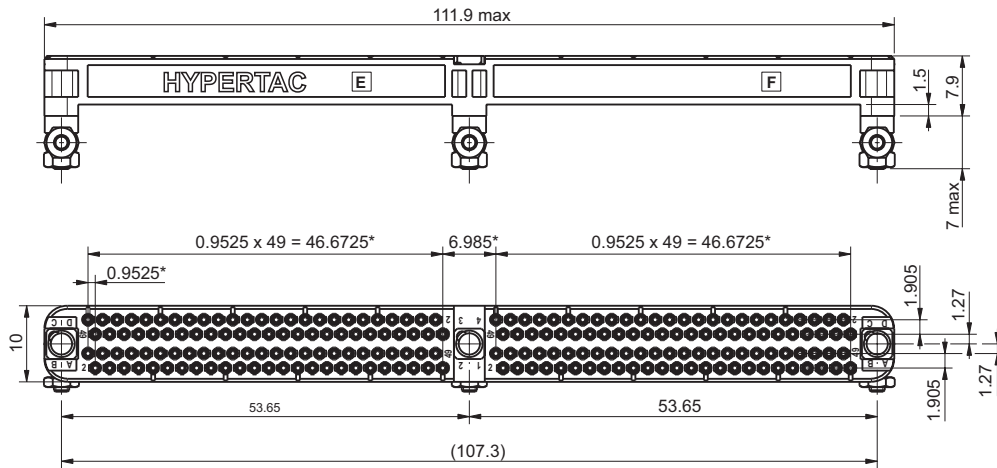

* Theoretical dimensions.

Guide and Termination Styles

Receptacle

Through board solder - 90°

Guide: 134

Ref: 10
PCB: 1.44 - 1.76

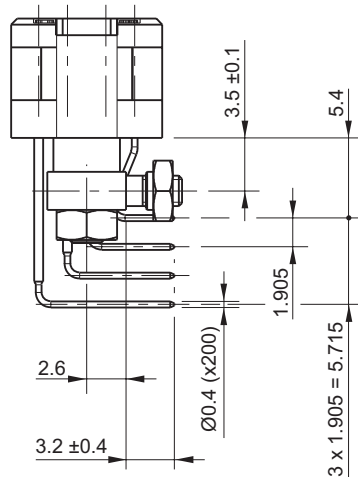

Through board solder - Straight

Guide: 122

Ref: 96
PCB: 3.42 - 4.18

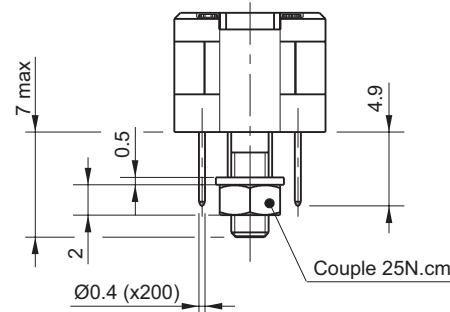

Plug

Through board solder - Straight

Guide: 114

Ref: 31
PCB: 2.88 - 3.52

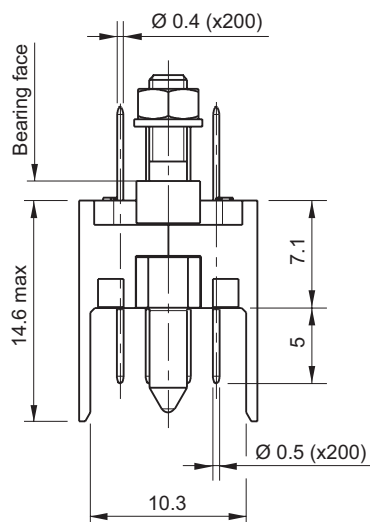

Surface mount (uncentered PCB)

Guide: 125

Ref: 44
PCB: 3.60 - 4.00

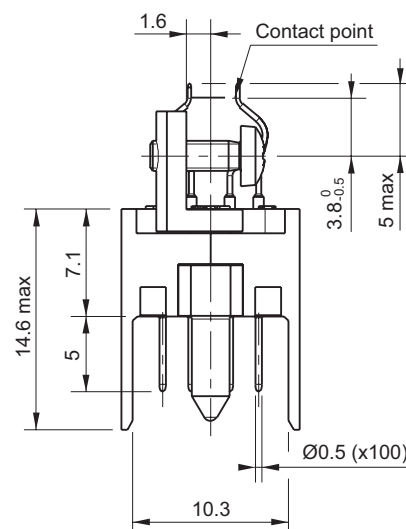

Note: for other guide styles requested, please contact technical support.

Contact Board Preparation Details

200 Contact Board Preparation Details

Receptacle

Straight termination

Guide: 122

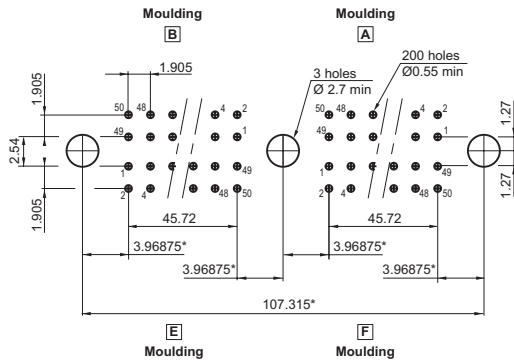

90° Termination

Guide: 134

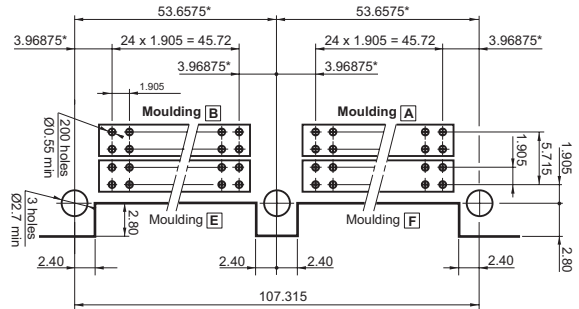

Plug

Straight termination

Guide: 114

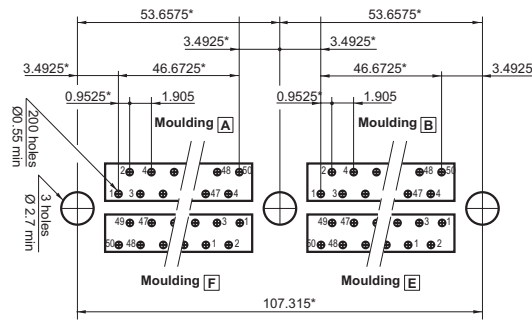

Surface mount termination

Guide: 125

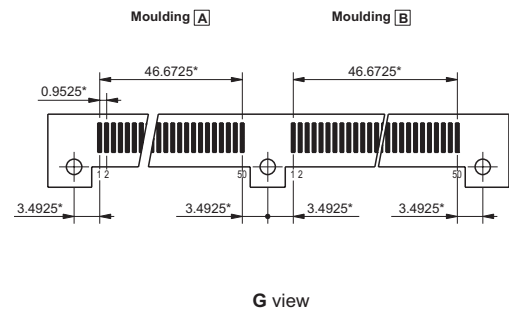
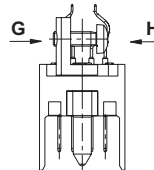
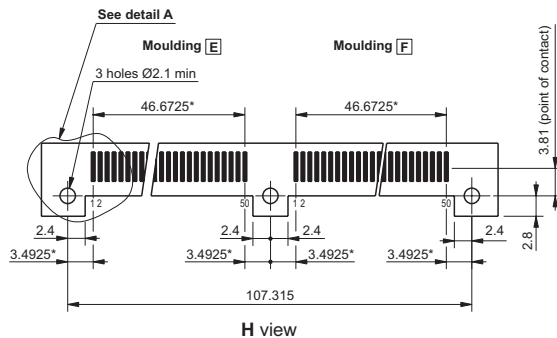

* Theoretical dimensions.

Disclaimer

All of the information included in this catalogue is believed to be accurate at the time of printing. It is recommended, however, that users should independently evaluate the suitability of each product for their intended application and be sure that each product is properly installed, used and maintained to achieve desired results.

Smiths Interconnect makes no warranties as to the accuracy or completeness of the information, and disclaims any liability regarding its use.

Smiths Interconnect reserves the right to modify design and specifications, in order to improve quality, keep pace with technological development or meet specific production requirements.

No reproduction or use without express permission of editorial and pictorial content, in any manner.

Product Portfolio

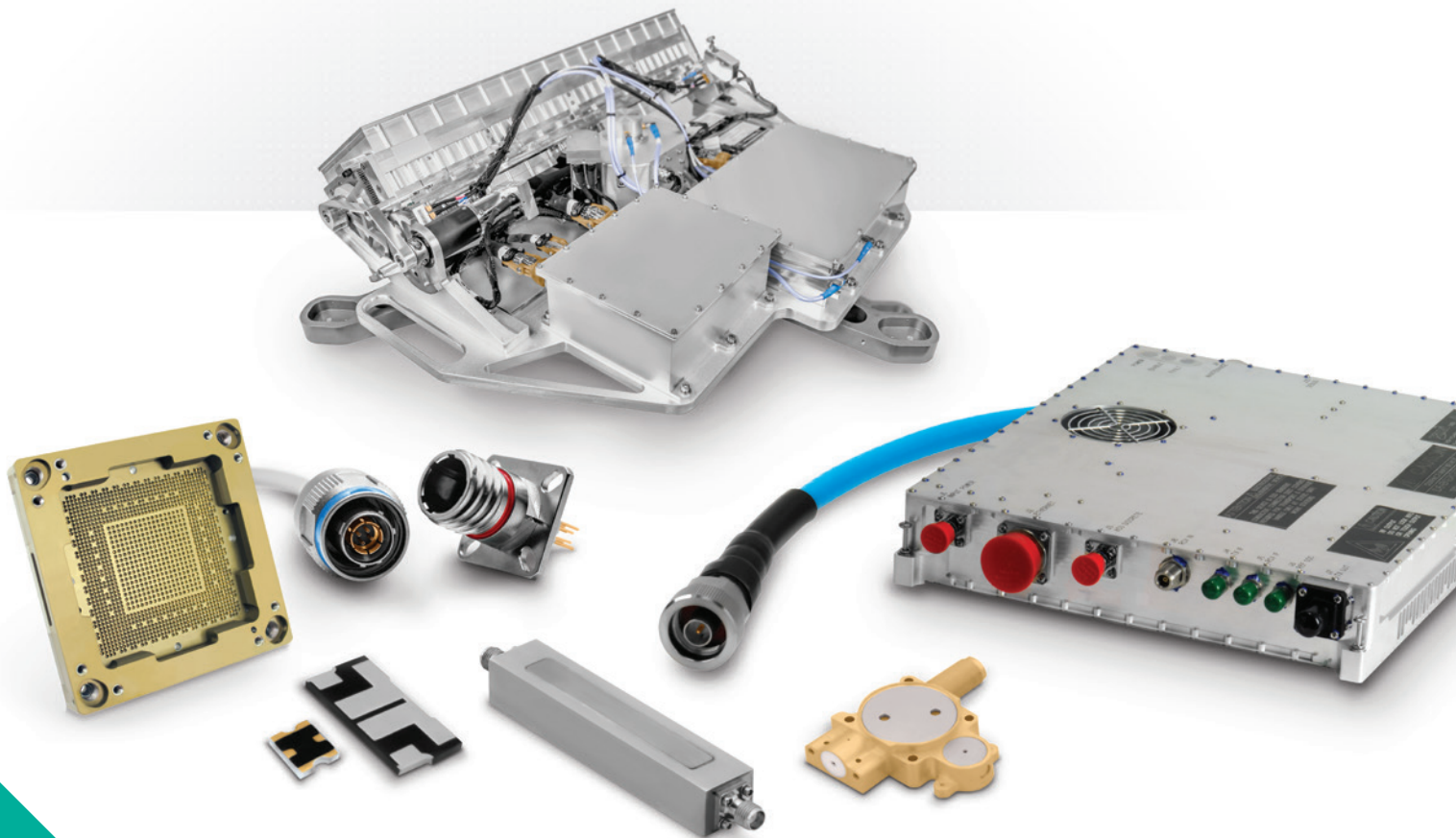

- Antenna Systems
 - Cable Assemblies
 - Connector Solutions
 - Ferrite Components & Assemblies
 - RF Filter Components & Assemblies
 - Integrated Microwave Assemblies
 - Millimeter-Wave Solutions
 - RF Components
 - Test Sockets and WLCSP Probe Heads
 - Time & Frequency Systems

Worldwide Support

Connectors

Americas

Sales

connectors.uscsr@smithsinterconnect.com

Technical Support

connectors.ustechsupport@smithsinterconnect.com

Europe

Sales

connectors.emeacsr@smithsinterconnect.com

Technical Support

connectors.emeatechsupport@smithsinterconnect.com

Asia

Sales

asiacsr@smithsinterconnect.com

Technical Support

asiatechsupport@smithsinterconnect.com

Fiber Optics & RF Components

Americas

Sales

focom.uscsr@smithsinterconnect.com

Technical Support

focom.techsupport@smithsinterconnect.com

Europe

Sales

focom.emeacsr@smithsinterconnect.com

Technical Support

focom.techsupport@smithsinterconnect.com

Asia

Sales

focom.asiacsr@smithsinterconnect.com

Technical Support

focom.techsupport@smithsinterconnect.com

Semiconductor Test

Americas

Sales

semi.uscsr@smithsinterconnect.com

Technical Support

semi.techsupport@smithsinterconnect.com

Europe

Sales

semi.emeacsr@smithsinterconnect.com

Technical Support

semi.techsupport@smithsinterconnect.com

Asia

Sales

semi.asiacsr@smithsinterconnect.com

Technical Support

semi.techsupport@smithsinterconnect.com

RF/MW Subsystems

Americas, Europe & Asia

Sales

subsystems.csr@smithsinterconnect.com

Technical Support

subsystems.techsupport@smithsinterconnect.com

Connecting Global Markets

more > [smithsinterconnect.com](https://www.smithsinterconnect.com) | [in](#) [twitter](#) [youtube](#)