

TITLE: SPECIFICATION CONTROL DRAWING

PART IDENTIFIER: MTVA0X00N0XS

X TEMPERATURE COEFFICIENT OF ATTENUATION 1×10^{-3} DB/DB/°C.

SHIFT (NEG)	DB VALUE	FREQUENCY RANGE
-0.003	1, 2, 3, 4, 5, 6, 8	DC - 18 GHZ
-0.004	1, 2, 3, 4, 6	
-0.005	1, 2, 3, 4, 5, 6, 8	
-0.006	2, 3, 4, 5, 6, 7	DC - 12.4 GHZ
-0.007	2, 3, 4, 5, 6, 7, 8	
-0.009	2, 3, 6, 7	

ATTENUATION SHIFT NEGATIVE.

X DB VALUE SEE TABLE ABOVE.

DESCRIPTION: TEMPERATURE VARIABLE CHIP ATTENUATOR.

ASSEMBLY DWG: 1901004

1.0 SPECIFICATIONS:

- 1.1 ELECTRICAL:
 - 1.1.1 IMPEDANCE: 50 OHMS NOMINAL.
 - 1.1.2 OPERATING FREQUENCY RANGE: SEE TABLE ABOVE.
 - 1.1.3 ATTENUATION VALUES AVAILABLE: SEE TABLE ABOVE.
 - 1.1.4 ATTENUATION ACCURACY AT 25°C: $\pm 0.5\text{DB @ 1 GHZ}$.
 - 1.1.5 VSWR: 1.30:1 MAX. @ 1GHZ.
 - 1.1.6 INPUT POWER: 200 MILLIWATTS CW.
 - 1.1.6.1 FULL RATED POWER TO 125°C, DERATED LINEARLY TO 0 WATTS AT 150°C.
 - 1.1.7 TEMPERATURE COEFFICIENT OVER OPERATING TEMPERATURE RANGE: SEE TABLE ABOVE, TEMPERATURE COEFFICIENT TOLERANCE: $\pm 0.001 \text{ DB/DB/°C}$.
- 1.2 MECHANICAL:
 - 1.2.1 OUTLINE DWG: SEE SHEET 2.
 - 1.2.2 WORKMANSHIP: PER MIL-PRF-55342.
- 1.3 ENVIRONMENTAL:
 - 1.3.1 OPERATING TEMPERATURE RANGE: -55°C TO +150 °C.

2.0 UNIT MARKING: DB VALUE (X), DIRECTION OF SHIFT (N) AND TCA SHIFT (X).
LEGIBILITY AND PERMANENCY PER MIL-STD-130.

3.0 QUALITY ASSURANCE:

- 3.1 SAMPLE INSPECT PER ANSI/ASQC Z1.4 GENERAL INSPECTION, LEVEL II, AQL = 1.0.
 - 3.1.1 VISUAL AND MECHANICAL EXAMINATION FOR CONFORMANCE TO OUTLINE DRAWING REQUIREMENTS.
- 3.2 SAMPLE INSPECTION (DESTRUCTIVE TESTING).
 - 3.2.1 SELECT THREE (3) UNITS FROM LOT AND MEASURE DCA EVERY 20°C OVER THE TEMPERATURE RANGE -55°C TO +125°C.
 - 3.2.1.1 CALCULATE, USING LINEAR REGRESSION, THE SLOPE OF THE CURVE.
 - 3.2.1.2 CALCULATE TCA USING THE FOLLOWING FORMULA:

$$\text{TCA} = \frac{\text{SLOPE}}{\text{ATTENUATION @ 25°C}}$$
 - 3.2.1.3 ACCEPTANCE LIMITS: PER 1.1.7.
- 3.3 INSPECTION IN ACCORDANCE WITH 824W170 AND 824F036 FOR COMMERCIAL GRADE PRODUCT.
- 3.4 TEST DATA REQUIREMENTS:
 - 3.4.1 NO TEST DATA REQUIRED FOR CUSTOMER.
 - 3.4.2 DATA RETENTION - 24 MONTHS.

4.0 PACKAGING: STANDARD PACK PER 755W002.

EMC TECHNOLOGY 8851 SW OLD KANSAS AVE. STUART, FL 34997	CAGE CODE # 24602		DWG #	1004975000
	CHANGE NOTICE	EN 12-0212	REV LVL	W
			SHEET	1 OF 2

PART ID REF
MTVAS

U.S. PATENT NO. 5332981

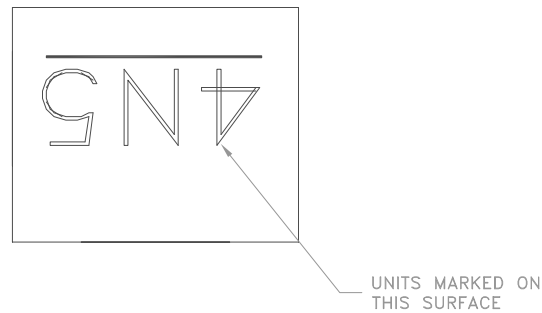
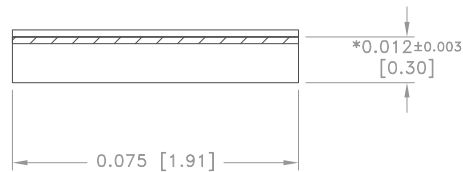
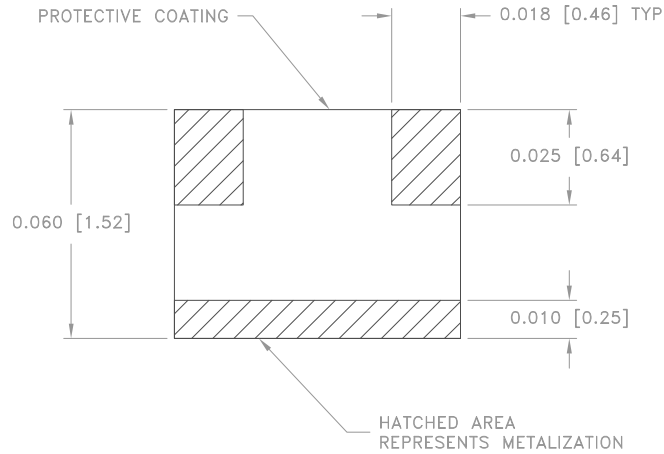

MECHANICAL SPECIFICATIONS:

SUBSTRATE:
MATERIAL - ALUMINA 96%, MIL-I-10.
TERMINAL:
MATERIAL - THICK FILM, NICKEL BARRIER, SOLDER COATED.
RESISTIVE ELEMENT:
MATERIAL - THICK FILM.

METRIC EQUIVALENTS GIVEN IN [mm] FOR REFERENCE INFORMATION ONLY

* DIMENSIONS APPLY BEFORE SOLDER. ALLOW 0.015 MAX FOR ALL PRETINNED SURFACES.

POWER RATING AND DERATING

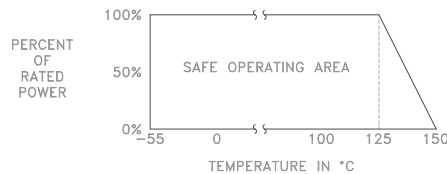

EMC Technology
8851 SW OLD KANSAS AVE
STUART, FL 34997
PHONE NO. (772)286-9300
FAX NO. (772)283-5286

UNLESS OTHERWISE SPECIFIED DIMENSIONS ARE IN INCHES
TOLERANCES
FRACT ---
ANG ---
XX ---
XXX ±0.005
XXXX ---

THESE DRAWINGS AND SPECIFICATIONS ARE THE PROPERTY OF EMC TECHNOLOGY INC AND SHALL NOT BE DUPLICATED OR USED AS BASIS FOR THE MANUFACTURE OR SALE OF PARTS OR DEVICES WITHOUT PERMISSION.

CAGE CODE	SCALE	DRAWN BY	CHECKED BY	APPROVED BY
24602	N/A	JG 2/15/10		
REV	CHANGE NOTICE	DRAWING NO	SHEET	
W	12-0212	1004975000	2 OF 2	