

MIL-DTL-83723

MIL-DTL-83723 Series III / MIL-DTL-26500 filter connectors are designed to meet or exceed all applicable requirements of the military specifications. The filter connectors are intermateable and interchangeable with standard non-filtered connectors.

Smiths Interconnect designs and manufactures a full spectrum of sophisticated filter connector products. Our specialty is in the design of interconnect solutions addressing EMI/RFI filtering, and transient protection to meet demanding HIRF and Lightning requirements.

In addition to MIL-Spec interface type products, many of our designs are unique, built to conform to customer specifications requiring a high level of integration, special packaging, and critical electrical performance. Innovation is our distinction and our products address a wide variety of applications. Our achievements lead the industry in the design and manufacture of special filter connector products.

Our Design Strategy

Smiths Interconnect's design strategy for filter connectors is based on extensive experience with filter capacitor arrays and diodes. Our engineers understand the extreme environmental conditions that can cause a filter or diode to fail or, worse yet, cause a system dysfunction. This design strategy is built on the foundation of system reliability and the efficient use of available space. The capacitor array is protected from thermally induced mechanical stresses by a barrier located between the capacitor array surface and the epoxy filled region. This barrier isolates the epoxy and the ceramic array and prevents damage to the array from the expansion influence of the epoxy.

Modularization

Smiths Interconnect uses a disciplined design approach that employs methods of grouping multiple components into subassemblies wherever feasible. Such subassemblies may include a filter module, diode module, circuit assembly module and a transition interface assembly. Modularization results in cleaner, more standardized designs that provide flexibility in maintaining and upgrading the connector. An important advantage of modularization is that individual modules may be removed or replaced in the field without disturbing other subassemblies and components.

Integration

There is considerable unused space available in a standard non-filtered connector. Smiths Interconnect takes advantage of this space by removing components from elsewhere in the system and integrating them within the connector, freeing up valuable board space. Isolating components electrically eliminates external wire connections and decreases crosstalk. The connector shell protects critical components from environmental or mechanical damage.



Type T



Type B

Material and Finishes

Shell	Aluminum alloy/Steel/Composite
Insulator	High grade plastic/epoxy
Contacts	Copper alloy, gold plate
Grommet & Seal	Silicon base elastomer
Jam Nut	Aluminum alloy
Ground Plane	Brass, silver plate
Capacitor	Barium Titanate
Inductor	Ferrite bead

MIL-DTL-83723

Square Flange Receptacle - Type B

Shell Size	A Max	K BSC	L	J Dia	F Dia	X Max Dia
8	0.120	0.594	0.812	0.561	0.536 0.531	0.500
10	0.120	0.719	0.937	0.696	0.659 0.654	0.620
12	0.120	0.812	1.031	0.875	0.829 0.824	0.740
14	0.120	0.906	1.125	0.925	0.898 0.893	0.890
16	0.120	0.969	1.250	1.062	1.025 1.020	1.000
18	0.120	1.062	1.343	1.187	1.131 1.126	1.120
20	0.120	1.156	1.437	1.312	1.256 1.251	1.250
22	0.120	1.250	1.562	1.437	1.381 1.376	1.390
24	0.149	1.375	1.703	1.562	1.506 1.501	1.500

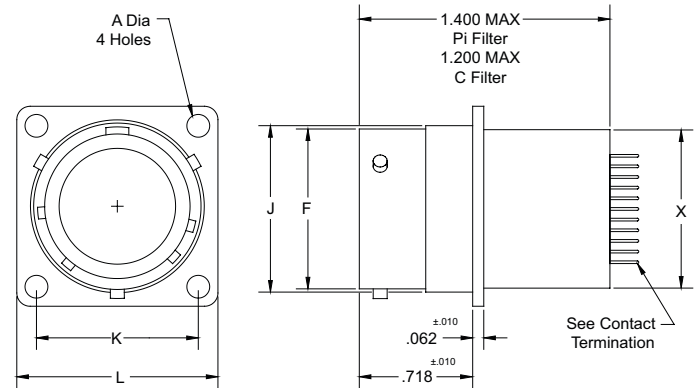





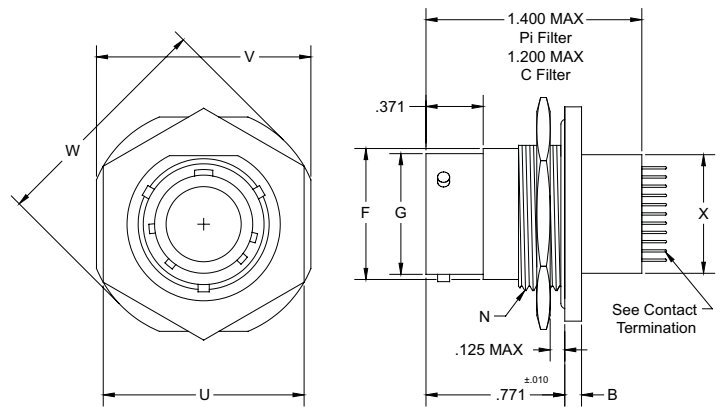























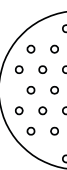

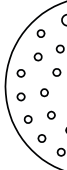

Jam Nut Receptacle - Type B

Shell Size	B	F Dia	G Dia	N Thrd	U	V	W	X
8	0.137 0.097	0.561	0.536 0.531	0.625-20	0.670	0.979	1.068	0.500
10	0.137 0.097	0.696	0.659 0.654	0.750-20	0.796	1.104	1.192	0.620
12	0.113 0.097	0.875	0.829 0.824	0.9375-20	0.984	1.291	1.380	0.740
14	0.137 0.097	0.935	0.898 0.893	1.000-20	1.046	1.391	1.505	0.890
16	0.137 0.097	1.062	1.025 1.020	1.125-20	1.171	1.516	1.630	1.000
18	0.137 0.097	1.187	1.131 1.126	1.250-18	1.296	1.641	1.756	1.120
20	0.137 0.097	1.312	1.256 1.251	1.375-18	1.484	1.766	1.860	1.250
22	0.168 0.128	1.437	1.381 1.376	1.500-18	1.609	1.954	2.068	1.390
24	0.168 0.128	1.562	1.506 1.501	1.625-18	1.734	2.079	2.160	1.500

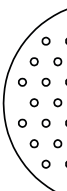

Smiths Interconnect provides specialty, enhanced performance connectors and cable assemblies and as such does not currently offer circular, rack and panel, or D-subminiature connectors that are listed on military standard Qualified Products Lists (QPL) per applicable detail specification sheets. Smiths Interconnect connectors are fully interchangeable with applicable QPL products and meet the applicable requirements of all military standards listed in this catalog.

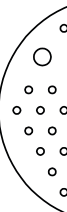
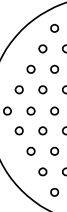
MIL-DTL-83723 Layouts

 2 #20 8-2	 3 #20 8-3	 3 #20 8-98	 2 #20 10-2	 5 #20 10-5	 6 #20 10-6	 2 #16 10-20	 3 #16 12-3
 12 #20 12-12	 2 #16, 1 #8 COAX 14-3	 4 #12 14-4	 7 #16 14-7	 9 #20, 3 #16 14-12	 15 #20 14-15	 10 #16 16-10	
 24 #20 16-24	 8 #12 18-8	 10 #16, 1 #8 COAX 18-11	 14 #16 18-14	 31 #20 18-31	 16 #16 20-16		
 19 #20, 6 #12 20-25	 24 #20, 4 #12 20-28	 37 #20, 2 #16 20-39	 41 #20 20-41	 12 #12 22-12			
 19 #16 22-19	 26 #20, 6 #12 22-32	 27 #20, 12 #16 22-39	 55 #20 22-55				
 23 #20, 20 #16 24-43	 55 #20, 2 #12 24-57	 61 #20 24-61	 Custom Layout* XX-XX				

MIL-DTL-83723

How to Order

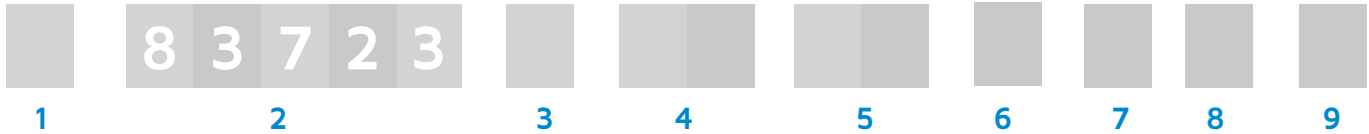

1 Filter Type	Pi, L, C,
2 Prefix	
3 Shell Style	J Jam Nut F 4 Hole Flange
4 Shell Size	8 Thru 24
5 Insert Arrangement	
5 Contact Type	P Pin S Socket
6 Contact Termination	S Solder Cup P PC Tail C Crimp
7 Plating	C Olive Drab Cadmium Over Nickel N Electroless Nickel
8 Polarization	N, 6, 7, 8, 9

Electrical Performance

Electrical Characteristics - 'Pi' Section

Filter Description	P200	P100	P76	P38	P20	P10	P8	P4	P2	P1	
Operating Temperature Range			-55°C to +125°C								
Voltage Rating	100 VDC		200 VDC-120 Vrms 400 Hz								
Current Rating DC			15 amps size 16 7.5 amps size 20 5 amps size 22								
Insulation Resistance			5000 megaohms min. @100 VDC								
Current Rating R.F.			3.0 amps max.								
DWV Sea Level w/ 50 micro-amps max. charge/discharge	250 VDC		500 VDC								

'Pi' Section Curves

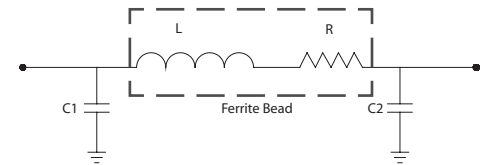
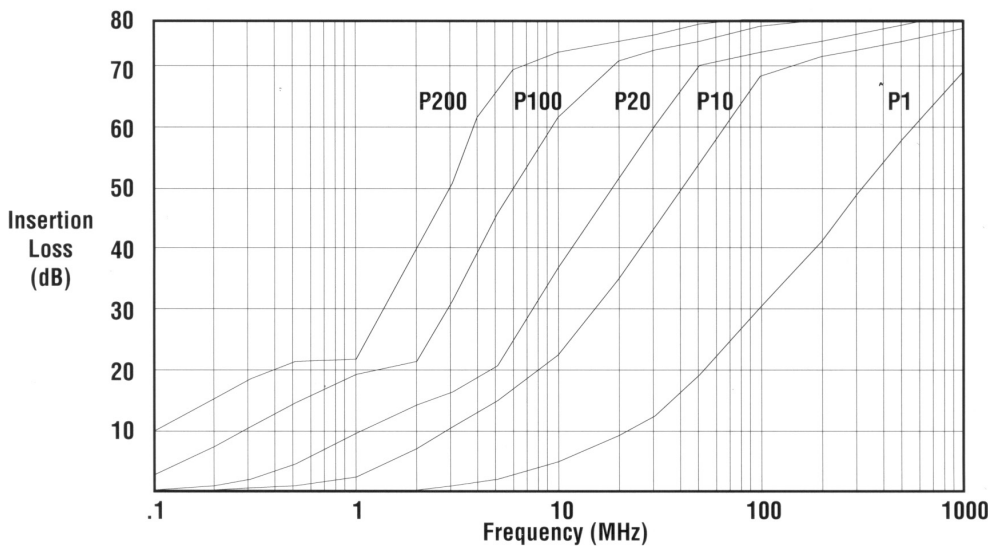

Insertion Loss Table

Filter Description	See Notes	P200	P100	P76	P38	P20	P10	P8	P4	P2	P1
Capacitance in Nanofarads @ 1Khz, 1VRMS		160 240	80 120	60 91	30 46	16 24	8 12	6.4 9.2	3.2 4.8	1.6 2.4	0.8 1.2
Minimum No Attenuation loss @ 25°	Freq Mhz										
	0.1	8	4.1	3	1	0.3	0.1	-	-	-	-
	1.0	22.2	19.6	18.2	13.3	8.2	3.9	2.9	0.9	0.2	-
	2	32.8	21.7	19.7	16.8	12.7	8	6.6	2.9	1	0.3
	10	73.5	61	57	44.4	31.5	20.6	18.3	12.8	8.1	4.0
	100	85+	85+	85+	85+	78	65.8	61.9	49.6	37.3	25.6
	500-1k	85+	85+	85+	85+	85+	85+	80	75	64	52

Notes:

1. P200 & P100 Capacitance Values for Size 20 Contact Arrangement & Larger
2. No Load Minimum Attenuation Values per MIL-STD-220
3. Capacitance in Nanofarads (Nominal Value)
4. Consult Factory for Higher Voltages & Capacitance Values

Electrical Performance

Electrical Characteristics - 'L' Section

Filter Description	L200	L100	L76	L38	L20	L10	L8	L4	L2	L1
Operating Temperature Range				-55°C to +125°C						
Voltage Rating	100 VDC			200 VDC-120 Vrms 400 Hz						
Current Rating DC				15 amps size 16 7.5 amps size 20 5 amps size 22						
Insulation Resistance				5000 megaohms min. @100 VDC						
Current Rating R.F.				3.0 amps max.						
DWV Sea Level w/ 50 micro-amps max. charge/discharge	250 VDC			500 VDC						

'L' Section Curves

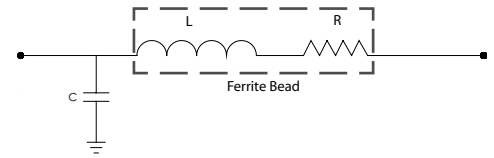
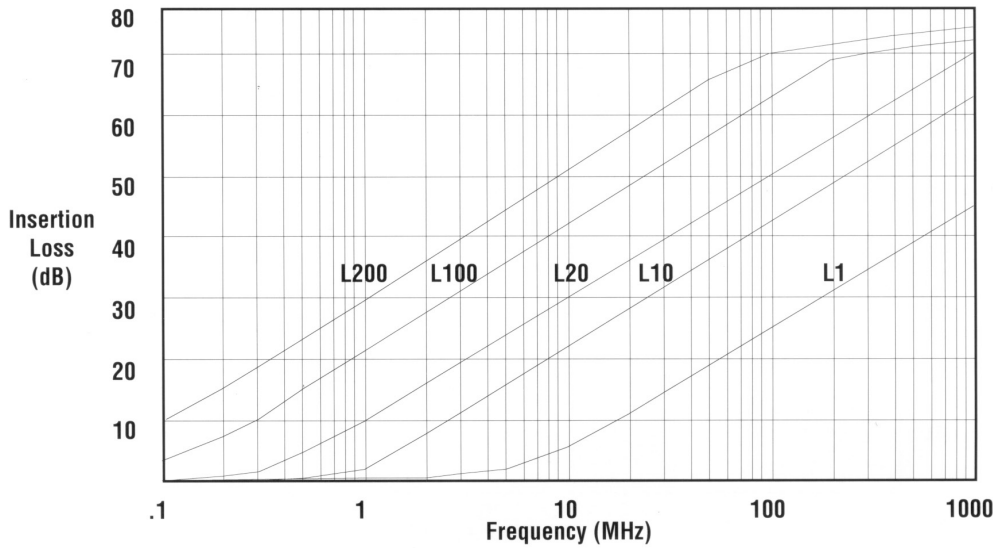

Insertion Loss Table

Filter Description	See Notes	L200	L100	L76	L38	L20	L10	L8	L4	L2	L1
Capacitance in Nanofarads @ 1Khz, 1VRMS		160 240	80 120	60 91	30 46	16 24	8 12	6.4 9.2	3.2 4.8	1.6 2.4	0.8 1.2
	0.1	8.6	4.1	3	1	0.3	0.1	-	-	-	-
	1.0	28	22	20.1	14.2	8.6	4	3	0.9	0.2	-
	2	34.3	28.3	26.3	20.3	14.4	8.8	7.2	3.1	1	-
	10	49	43	41.1	35	29	23	21.1	15.1	9.5	4.8
	100	69.9	63.9	62	55.9	49.9	43.9	42	35.9	29.9	23.9
	500-1k	83.7	77.7	75.8	69.7	63.7	57.7	55.8	49.7	43.7	37.7

Notes:

1. L200, L100 & L76 Capacitance Values for Size 20 Contact Arrangement & Larger
2. No Load Minimum Attenuation Values per MIL-STD-220
3. Capacitance in Nanofarads (Nominal Value)
4. Consult Factory for Higher Voltages & Capacitance Values

Electrical Performance

Electrical Characteristics - 'C' Section

Filter Description	C200	C100	C76	C38	C20	C10	C8	C4	C2	C1
Operating Temperature Range	-55°C to +125°C									
Voltage Rating	100 VDC									
Current Rating DC	15 amps size 16 7.5 amps size 20 5 amps size 22									
Insulation Resistance	5000 megaohms min. @100 VDC									
Current Rating R.F.	3.0 amps max.									
DWV Sea Level w/ 50 micro-amps max. charge/discharge	250 VDC					500 VDC				

'C' Section Curves

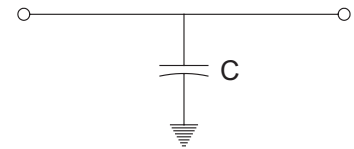
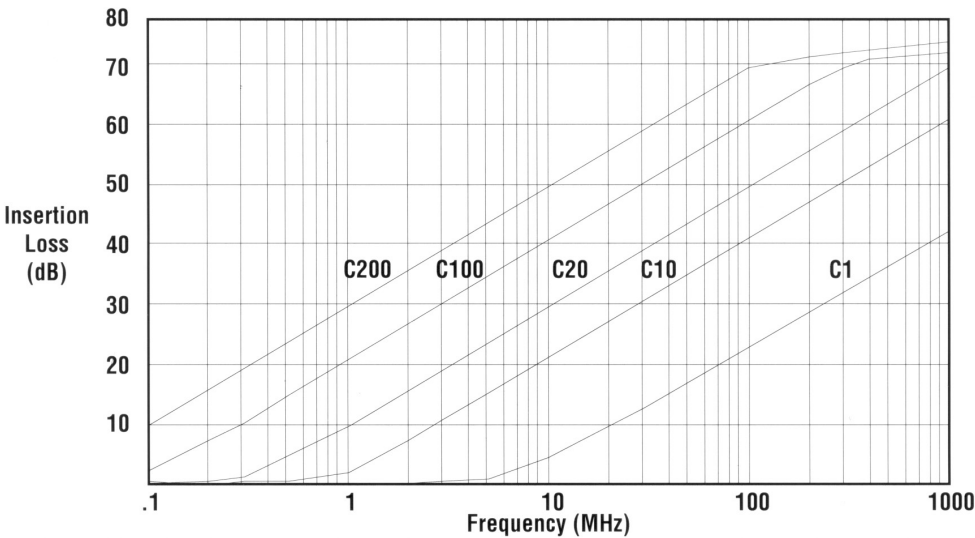

Insertion Loss Table

Filter Description	See Notes	C200	C100	C76	C38	C20	C10	C8	C4	C2	C1
Capacitance in Nanofarads @ 1Khz, 1VRMS		160 240	80 120	60 91	30 46	16 24	8 12	6.4 9.2	3.2 4.8	1.6 2.4	0.8 1.2
Minimum No Attenuation loss @ 25°	Freq Mhz										
	0.1	8.6	4.1	3	1	0.3	0.1	-	-	-	-
	1.0	28	22	20.1	14.2	8.6	4.1	3	1	0.3	0.1
	2	34	28	26.1	20.1	14.2	8.6	7	3	1	0.3
	10	48	42	40	34	28	22	20.1	14.2	8.6	4.1
	100	68	62	60	54	48	42	40	34	28	22
	500-1k	82	76	74	68	62	56	54	48	42	36

- Notes:
1. C200, C100 & C76 Capacitance Values for Size 20 Contact Arrangement & Larger
 2. No Load Minimum Attenuation Values per MIL-STD-220
 3. Capacitance in Nanofarads (Nominal Value)
 4. Consult Factory for Higher Voltages & Capacitance Values

Performance Data

Smiths Interconnect connectors conform to the applicable military specifications and standards for materials, finishes and mechanical form, fit, and function. Filter connectors are fully intermateable and interchangeable in most instances with standard non-filtered QPL MIL-SPEC connectors.

Material and Finishes

Shell & Jam Nut	Aluminum Alloy Electroless Nickel per MIL-C-26074
Pin Contacts	Brass per ASTM B16 Gold Plate per MIL-G-45204
Socket & Contacts	Copper Alloy Gold Plate per MIL-G-45204
Insulators	High Grade Plastic/Epoxy
Seal & Grommet	Silicon Base Elastomer



Production Automation Test System Measurements

	Range	Accuracy	Notes
Capacitance	1 pF-1 μ F	0.2% + 0.1 pF	1
DF	0.00001-10	1%	2
Inductance	100 nH-10KH	0.2%+10 nH	1
IR	1 K Ohm - 5 T Ohm	1%	3,4,5
DWV	10 μ A-100 mA	1%+10 μ A	3,4,6
VR	10 mV-100V	0.2% + 10 mV	7
Ground & Contact Resistance	0.1 mV-1V	0.1%+0.1 mV	7

Notes:

1. Frequency = 20 Hz to 1 MHz
2. Dissipation factor
3. With 5-500 Volts applied
4. Measures each pin to all other pins grounded to shell
5. Insulation resistance
6. Dielectric withstanding voltage
7. Isource = 1nA-1A

Performance Data

Smiths Interconnect Filter Connectors meet or exceed the applicable requirements of the following specifications:

MIL-DTL-38999 **MIL-C-26482**
MIL-DTL-83723 **MIL-DTL-26500**
MIL-DTL-24308 **MIL-DTL-83723**
MIL-DTL-83513 **MIL-C-81511**
MIL-DTL-83527 **ARINC 600**
ARINC 404 (MIL-C-81659)

Smiths Interconnect connectors can meet qualification requirements of MIL-DTL-38999, MIL-C-26482, ARINC 404 (MIL-C-81659), and ARINC 600. Smiths Interconnect can perform most test requirements in-house. This includes both electrical and mechanical testing for qualification, engineering evaluation and final acceptance. All products are available for space grade applications.

All specifications subject to change without notice.

Smiths Interconnect provides specialty, enhanced performance connectors and cable assemblies and as such does not currently offer circular, rack and panel, or D-subminiature connectors that are listed on military standard Qualified Products Lists (QPL) per applicable detail specification sheets. Smiths Interconnect connectors are fully intermateable with applicable QPL products and meet the applicable requirements of all military standards listed in this catalog.

Contact Termination

PC TAIL

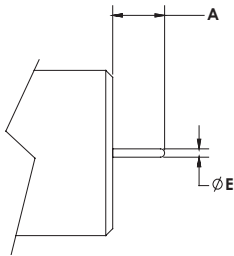
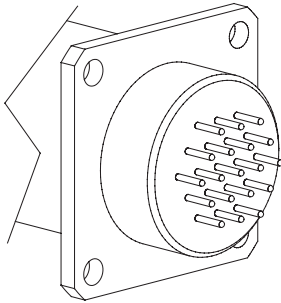

SOLDER CUP

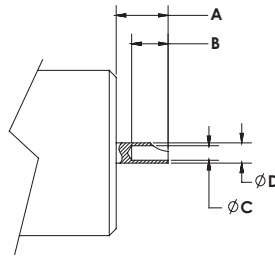
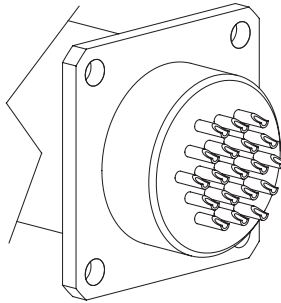

COMPLIANT PRESS-FIT (SOLDERLESS)

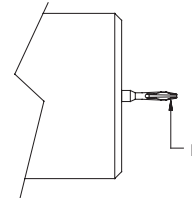
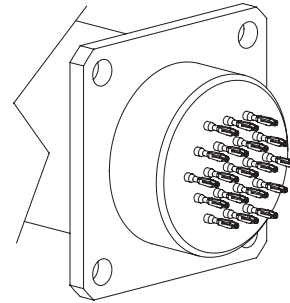

Contact Size	A +.025	B	C	D	E +.003	F
22	0.175	0.125 0.094	0.040 0.035	0.055 0.051	0.020	PCB Finished Hole 0.026 + 0.002
20		0.156 0.125	0.048 0.042	0.088 0.061	0.030	
16		0.172 0.141	0.082 0.069	0.103 0.097	0.050	Consult factory for alternate size
12		0.120 0.112	0.142 0.136	0.065		

Crimp / Removable*

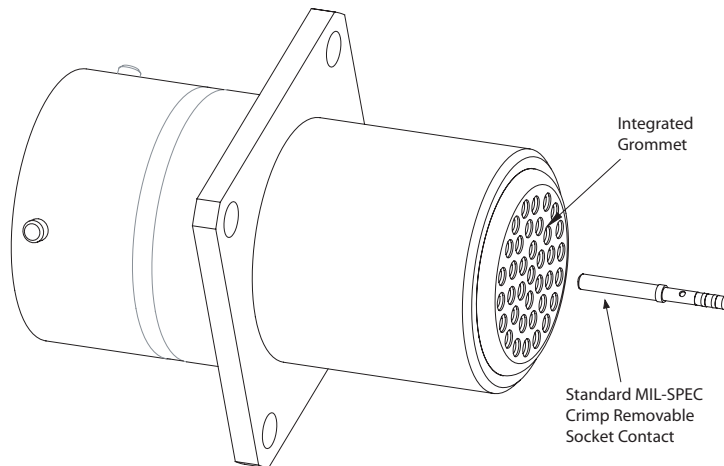

* Add 0.700" to overall length for crimp removable connector with integrated grommet.