

Wrapped Chip Device Mounting Instructions

This line of microwave attenuators is designed for surface mount and wraparound grounding applications. The W1 has a platinum gold wraparound ground with full back metallization and platinum gold input/output terminations. The WB1 has a platinum gold wraparound ground and gold input/output terminations for wire bonding. The W3 type has wraparound metallization on all three terminals with small contact pads on the back side. This application note describes the mounting techniques for each attenuator type to optimize RF performance, heat sinking, and mechanical support.

OVERVIEW

Each of the three wraparound configurations is designed for a specific mounting application. As with many surface mount devices, the electrical connections are also used to provide mechanical support. You may use epoxy if additional reinforcement is necessary. **Figures 1, 2 and 3** show the typical mounting methods for each part type. The recommended attachment technique for each style is shown in **Table 1**.

Table 1 W1 WB1 W3*

Term	Ground	Term	Ground	Term	Ground
Epoxy	X		X	X	X
Wire Bond		X			
Preform	X		X		
Tabs	X				
Paste	X	X	X	X	X
Pretinned				X	X

* For maximum performance and reliability, W3 style parts should be mounted with film side down.

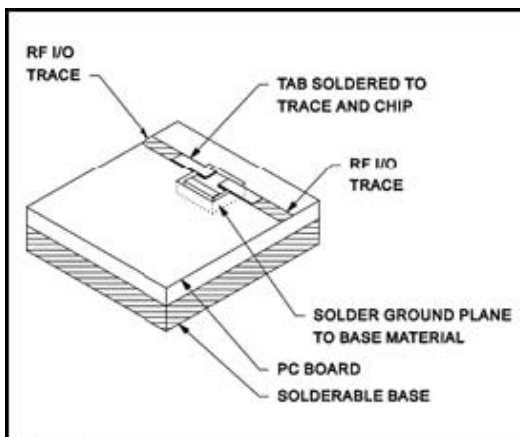

Figure 1

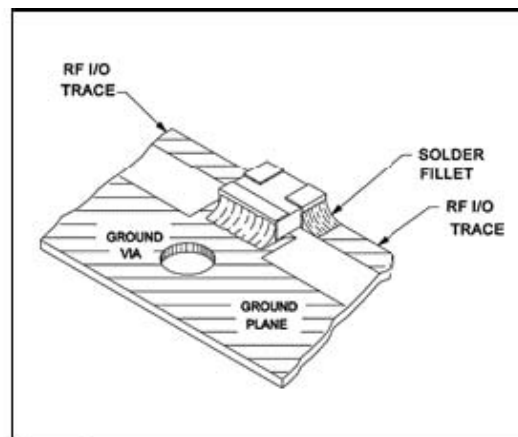

Figure 2

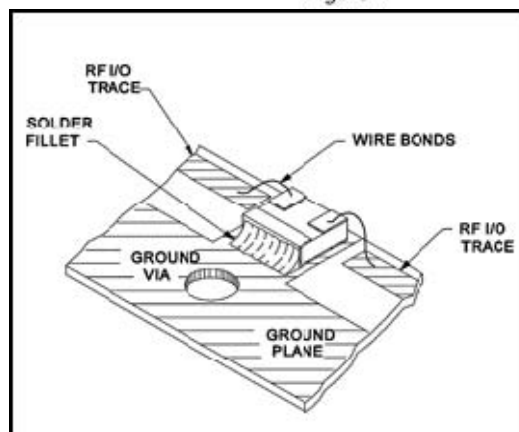

Figure 3

Wrapped Chip Device Mounting Instructions

When choosing an attachment technique, the primary concern is to achieve the desired RF performance. The W1, WB1 and W3 designs have been optimized for best performance when mounted according to the above guidelines. The most common use for these devices is on a 50 Ohm microstrip transmission line. RF performance will vary with the ground plane spacing under the device, as well as with the dielectric constant of any insulating material. Any device parasitic reactance can usually be compensated with external circuitry. In general, for attenuation values of 1 through 8 dB capacitance to ground should be minimized. This can be accomplished by using a thick, low dielectric constant ground plane spacing. For values of 8 dB and higher, the best performance is achieved when the device sits directly on ground. In all cases, grounding is critical. If the device is surface mounted, you must provide plated thru-holes in close proximity to the topside ground pad. Make the input and output termination connections with a low inductance bond. The W3 terminations produce such a bond simply by the design of the wraparound metallization. The W1 terminations are usually connected to the substrate using small tabs or wires. The width of the tab should be equal to the smaller of either the substrate line width or the chip pad size. The WB1 has wire bondable terminations. We recommend a low inductance ribbon bond or multiple wire bonds.

PART PREPARATION

Prior to mounting, both the parts and the mounting surfaces must be free of any impurities that may interfere with the attachment process. Common contaminants include finger oils, surface oxides and organic compounds associated with component processing and packaging.

Begin the cleaning process with a burnishing step on both surfaces. Use a solvent-resistant plastic eraser for this operation. After burnishing, clean both surfaces with a low boiling point solvent such as isopropyl alcohol. We suggest ultrasonic cleaning followed by a rinse.

EPOXY

You may use epoxy bonding for most applications but be aware that its most serious drawback is outgassing. When used in a sealed package, epoxy outgassing may contaminate other parts.

We recommend silver conductive epoxies for RF applications. Solvent-free epoxies, such as Ablestik 84- 1LMI or EPO-Tek H20E, are acceptable. The epoxy may be either screened or dispensed onto the substrate surface before setting the part on the board. Be sure that an epoxy fillet is visible to verify full coverage. For surface mounting the W3, minimize the epoxy under the chip to prevent spreading which could cause degraded performance or an unwanted connection between pads. Adding epoxy to the edge of the W3 will improve the electrical contact and add mechanical support.

Epoxy preforms may be used for the ground planes of the W1 and WB1. Ablestik ECF564A is a suitable conductive film adhesive. When using an epoxy preform, clamp the part in place with a spring clip or a weight to ensure that the preform adheres to both surfaces.

SOLDERING AND CIRCUIT BOARD CONSIDERATIONS

Success when soldering surface mount components depends upon the soldering surface. The size and location of the solder pads is critical. Provide a pad that is 0.010" to 0.020" over the termination size¹. Center the pad along the axis of the chip and bias it slightly from each end to allow for a solder fillet. Isolate the pads from the connecting lines to prevent solder wicking. Use either insulating solder dams over the conductors or narrow traces off the pads to assist in solder fillet formation. Failure to follow these guidelines can lead to component skewing and/or tombstoning² (draw bridging). **Figure 4** illustrates common pad design problems and solutions.

Figure 5 and **Figure 6** may be used as circuit board layout guidelines for TS0300W3 and TS0500W3 attenuators, respectively. For highest reliability, W3 components are best mounted with the attenuator film facing the circuit board. When mounted in this manner, the three terminations which make direct contact to the film also make contact to the traces on the circuit board. Six of the nine terminations of the W3 can be damaged without producing an electrical failure if the part is mounted with the film side down.

Wrapped Chip Device Mounting Instructions









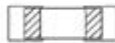

PAD DESIGN	RESULT
 PROPER PADS	 SELF CENTERED
 PADS TOO LONG	 TOMB STONED
 PADS TOO WIDE	 SKEWED
 PADS WITH NO RELIEF	 TOMB STONED
 PROPER RELIEF	 SELF CENTERED

Figure 4

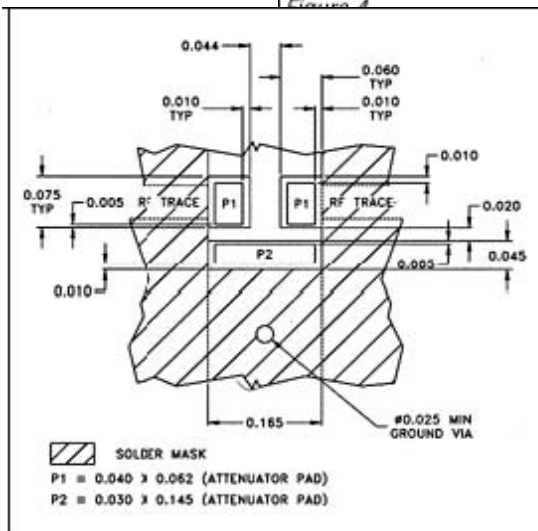

Figure 5

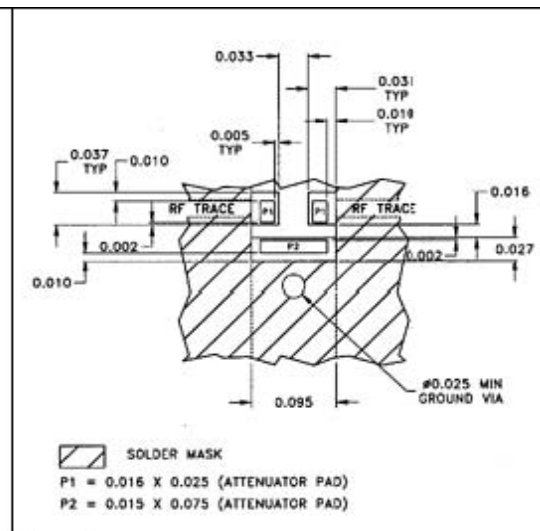

Figure 6

The W1 and WB1 components have full back metallizations and may therefore be subject to skewing. On the W3 parts, the pads on the underside of the part are designed to minimize the possibility of tombstoning. Pad size can help minimize tombstoning in two ways. First, by making the pad areas equal, the force from the surface tension of the liquid solder on the three pads will be equal. Second, since the chip is tipped by the lifting moment produced by the solder fillet, the smaller the chip height to pad width ratio is, the smaller will be the resulting lifting force. With the W3, the input and output pads are equal in area. This produces equal forces from front to back.

The ground pad is slightly larger than the input and output pads, therefore the side-to-side forces on the chip are equalized. Also, for both the TS0300 and TS0500, the largest height to width ratio is 0.75". Since this part exhibits little affinity for tombstoning, the ratio of 0.75" is a good guideline.²

Wrapped Chip Device Mounting Instructions

FLUX

Flux is an acid-based solution that is used to clean metal surfaces and remove any oxides prior to soldering. We recommend a mildly activated RMA flux (MIL-F-14256). You may apply the flux directly to all surfaces including the solder, or as part of the solder paste, preform, or wire.

PREFORMS

Preforms are solid sheets of solder, available with or without flux, that are used primarily for soldering large ground plane areas. Set the preform on a prefluxed surface with the chip positioned over it. Hold the chip in the proper position during reflow with a non-solder wetting jig (e.g., Vespel®, stainless steel, aluminum, etc.). Apply pressure to the top of the chip to prevent any trapped air from causing the part to tip or allowing gaps to form. The scrubbing action of a die bonder can prevent both. Die bonding is commonly performed using a heated stage with the reflow heat produced by a hot air torch or an infrared (IR) lamp. You may also solder the chip using a hot plate or a furnace reflow technique. Set the soldering schedule to minimize the duration and intensity of the part exposure to high temperatures. Limit the time on the hot plate to 3 minutes if you are using a good thermally conductive and moderate thermal mass fixture. A short soldering time interval will prevent flux “burning” and reduce the amount of brittle intermetallic compound formation in the solder joint. To ensure the formation of the proper solder fillet, select a preform size that is 0.005" to 0.010" larger than the size of the solder pad.

Sn62Pb36Ag2 solder (178°C eutectic) is recommended for all soldering operations, however, soldering temperatures of 250°C for 30 seconds will not damage the parts. Reference 4 gives appropriate furnace profiles for different solder materials.

SOLDER PASTE

Solder paste is a solution of solder, flux, and solvents. Other materials are often added to optimize the screening or dispensing operation. Drying the paste slightly prior to soldering will eliminate any solvents that might boil and cause solder splashes. However, care must be taken not to dry out the flux completely. When large areas must be pasted, screening is the preferred method because it provides an even and repeatable deposition.

Deposit the paste onto the substrate either by dispensing or screening. Next, place the chips on the pasted areas. The tackiness of the paste will hold the surface mounted components in place. Next, flow the parts by heating the substrate up to the soldering temperature. Starting with a preheating stage will help reduce the thermal shock to both the parts and the substrate. Follow the preheating with a second-stage heating up to the soldering temperature using an IR, soldering iron, flame, hot air torch, or with a furnace.

PRETINNING

Pretinning is the solder coating of the component and/or the substrate prior to soldering the two together. This is most often accomplished by dipping the parts in a pot of molten solder. You can pretin the substrate by plating during fabrication, or by depositing and reflowing solder paste. Remove excess solder with a squeegee wipe. Then follow the pasted reflow techniques described in the Solder Paste section above to solder the parts. Be particularly careful when pretinning these extremely small parts.

TABS

You can connect the input and output terminations of the W1 to the substrate with pretinned or gold-plated soft copper tabs. We suggest that you attach the tabs to the part using a high temperature solder (Sn 96.5 Ag 3.5, 220°C eutectic) and then join the tabs to the substrate using a standard Sn 62 (178°C eutectic). If higher temperature solders can't be used, solder the tabs by preheating the whole assembly to between 20° and 30°C below the soldering temperature. Then add heat to one side of the tab at a time.

CLEANING

After soldering, clean the substrate to remove any flux or residual solvents. Ultrasonic cleaning followed by a solvent rinse is the most common method. Most flux manufacturers will also supply effective flux solvents.

Wrapped Chip Device Mounting Instructions

WIRE BONDING

EMC supplies WB1 attenuators with gold terminations for wire and ribbon bonding. Thermal compression and ultrasonic wedge and ball bonding are the most common bonding methods. First, attach the chip to the substrate with epoxy or solder. Heat the substrate to about 150°C. A gold metallic bond will form between the wire and the bonding pad by adding thermal and/or ultrasonic energy while compressing them together. As with the soldering operation, clean all surfaces prior to bonding, as described in the Part Preparation section. KFA and KTVA are planar circuits with wire or ribbon bondable terminals, see figures 7, 8 and 9 for mounting examples.

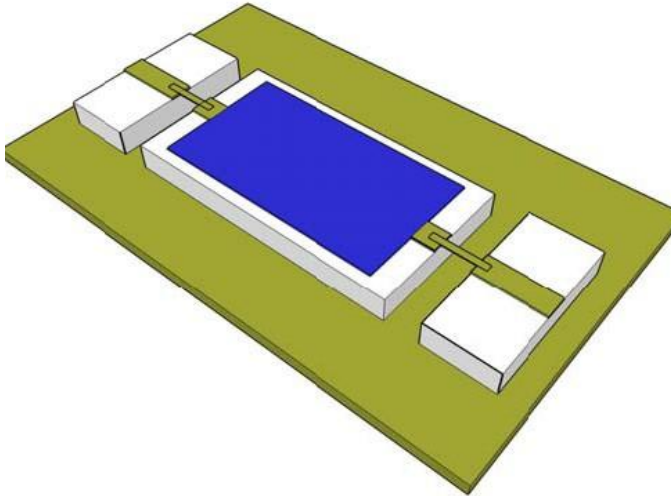

Figure 7 KTVA- KFA Ribbon Bond Mounting

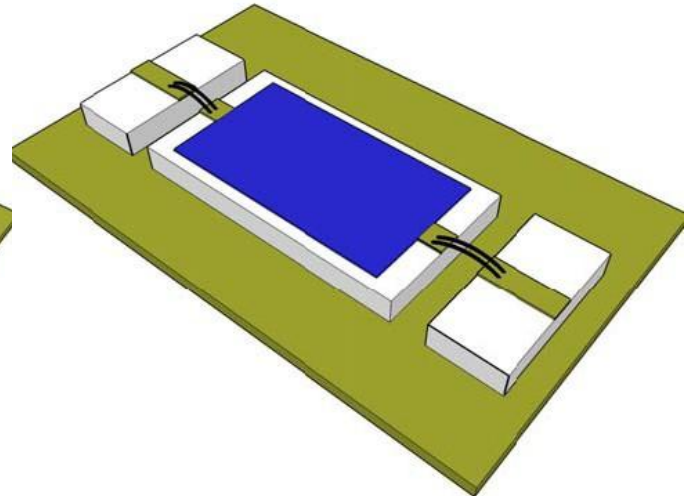

Figure 8 KTVA-KFA Wire Bond Mounting

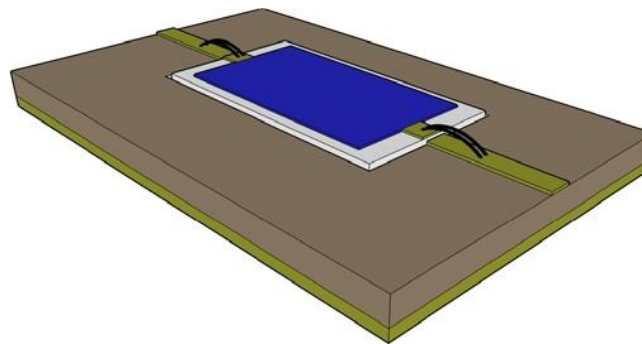

Figure 9 KTVA –KFA Wire Bond on PCB and solderable Ground plane

REFERENCES

- ¹ Erickson, David. "How to Design for Manufacturability." *Surface Mount Technology*. February 1989.
- ² Giordano, Jerry, and David Khoe. "Chip Resistor Design Helps Prevent Tombstoning." *Surface Mount Technology*, August 1988.
- ³ Harper, Charles A. *Handbook of Thick Film Hybrid Microelectronics*. McGraw Hill, Inc., 1974.
- ⁴ Manko, Howard H. *Solders and Soldering*. McGraw Hill, Inc., 1992.