

CEX Series

Equalizer Chip, DC-40 GHz

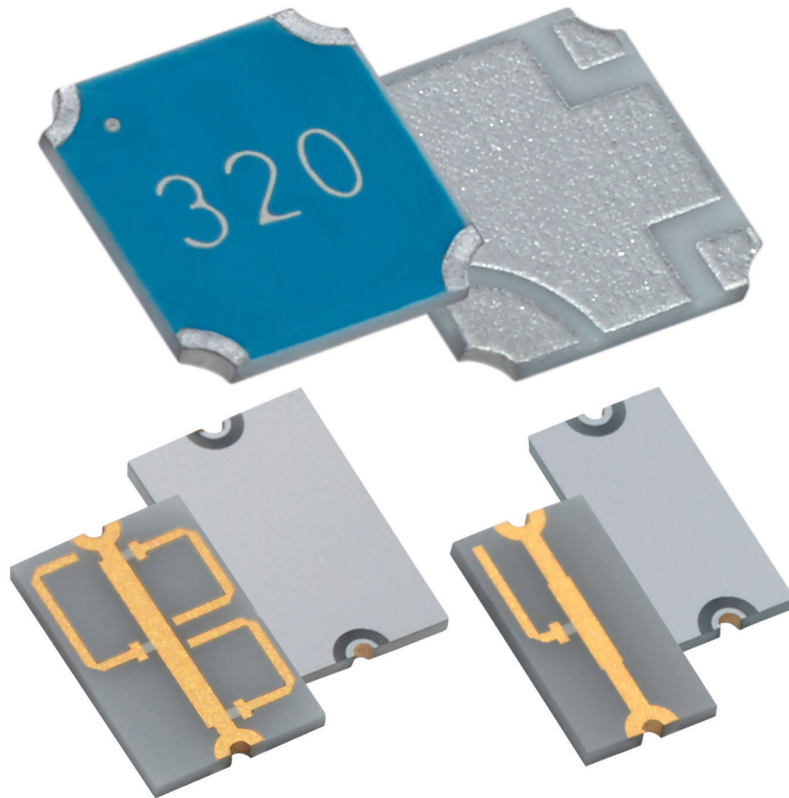

Chip Equalizer Series

EQUALIZER CHIP, DC-40 GHZ

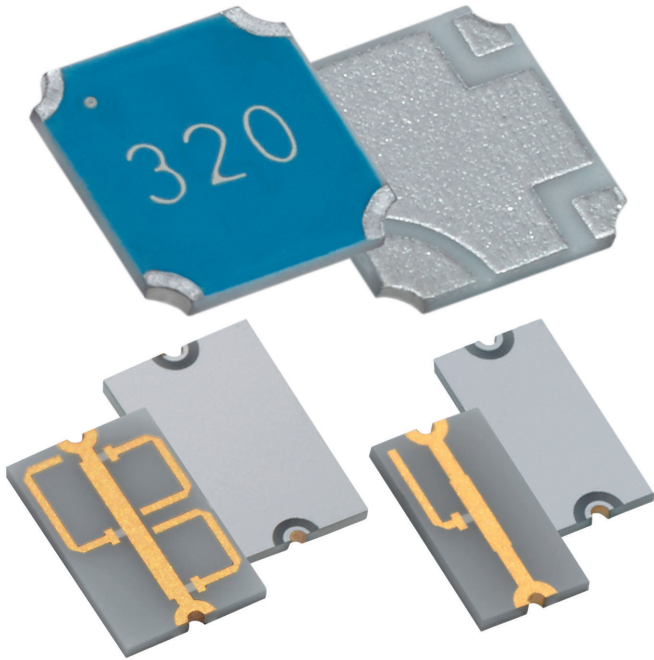

Smiths Interconnect offers a wide array of SMT chip equalizers optimized for gain variation over frequency. Various configuration options including frequency band, slope direction and slope magnitude are available to support various application demands.

The CEX range offers various compensation options from DC-40 GHz with multiple frequency bands and slope characteristics available. The products are designed for surface mount (SMT) applications and are manufactured using robust thick and thin film process technology. These products are also lead free, RoHS compliant and are available in tape and reel packaging for high volume pick and place applications.

The series includes high frequency chip equalizers that have as key distinctive characteristics a slope compensation range at 1-4 db, a slope linearity at ± 0.25 dB, a Voltage Standing Wave Ratio at 1.5:1 Max and a low insertion loss at 1 - 1.25 dB Max. The electrical and thermal performances have passed through simulation analysis and real-life tests to ensure the series qualification.

The CEX series platform is an easy to implement surface mount solution for gain (or attenuation) variation over frequency.

Features and Benefits

- Configurable design approach providing optimized solutions for gain variation over frequency.
- Multiple slope options (1-4 dB) and excellent slope linearity (± 0.25 dB or better).
- Frequency offering up to 40 GHz supporting a wide array of markets and applications.
- Proven thin and thick film process technology ensures high performance in harsh environments
- Constantly pushing the boundaries of size, weight and power with each new design.

Applications

- Amplifier Circuits
- Transmit/Receive Modules
- Up/Down Converters
- Instrumentation
- Radar
- Broadcast

Technical Characteristics

Chip Equalizer Capabilities	CEXXXXXXXXSMTF (Standard Equalizer)	CEHFXXXXXXXXSMTF (High Frequency)
-----------------------------	-------------------------------------	-----------------------------------

Electrical

Nominal Impedance	50 ohms	50 Ohms \pm 10%
Operating Frequency <small>*See Table For Currently Available Values</small>	Up to 10 GHz	Up To 40 GHz (in customizable bandwidth 20%)
Slope	1-4 dB	1-4 dB
Slope Linearity	\pm 0.25 dB	\pm 0.25 dB Minimum
Insertion Loss	1.25 dB Max	0.5 dB Typical, 1.0 dB Max
VSWR	1 dB Slope: 1.3:1 Max 2 dB Slope: 1.5:1 Max 3 dB Slope: 1.8:1 Max 4 dB Slope: 1.8:1 Min	1.50:1 Typical, 1.70:1 Max
Input Power CW	0.25 Watts	200 mW
Peak Power	-	2.0 Watts Max (Based on 10 μ S pulse width and 1.0% Duty Cycle)

Environmental

Operating Temperature	-55°C to +150°C
Storage Temperature	-65° to +150°C
Moisture Sensitivity Level	1 - Unlimited

Mechanical

Configuration	Surface Mount	
Package Size	Varies based on Slope and Frequency Requirements	
Substrate Material	Alumina (Al ₂ O ₃)	
Terminal Material	Thick Film, Nickel Barrier, Solderable Silver Plating	Thin Film Solderable Gold
Ground Plane Material	Thick Film, Nickel Barrier, Solderable Silver Plating	Thin Film Solderable Platinum
Resistive Element	Thin Film Nickel Chromium (NiCr)	Thin Film Tantalum Nitride (TaN)

Marking

Unit Marking	Part Mark Code, based on slope and frequency	None
--------------	--	------

Quality Assurance

	Sample visual and mechanical inspection - 1.0 AQL per mechanical drawing requirements. Periodic electrical inspection performed for commercial grade products. High Reliability tested products are available.
--	--

Packaging

Standard Packaging	Waffle Pack or Tape and Reel
--------------------	------------------------------

Electrical

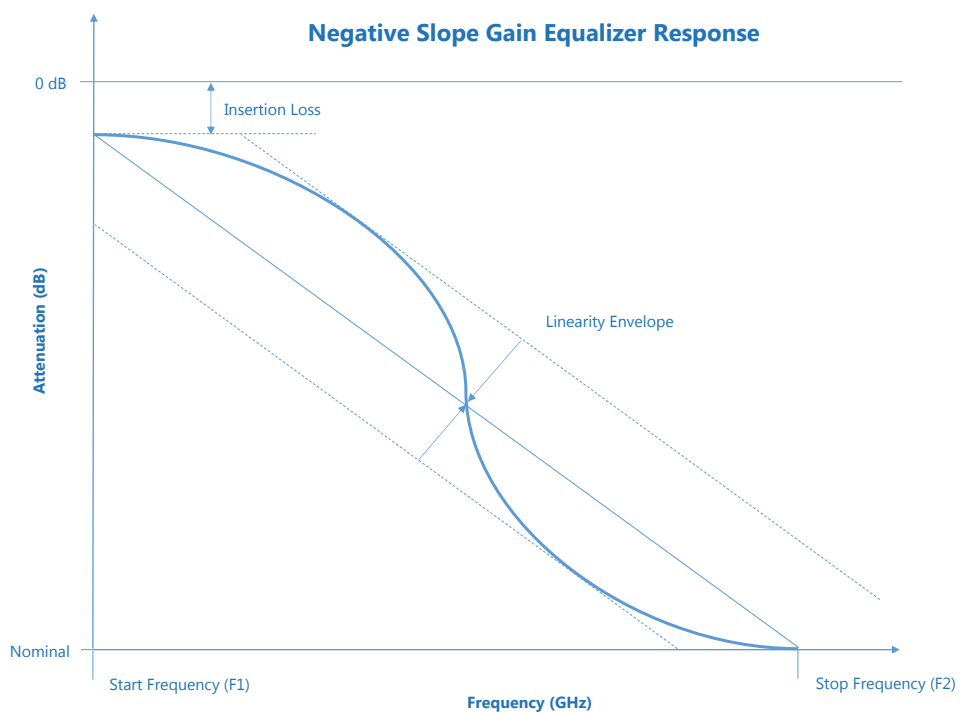
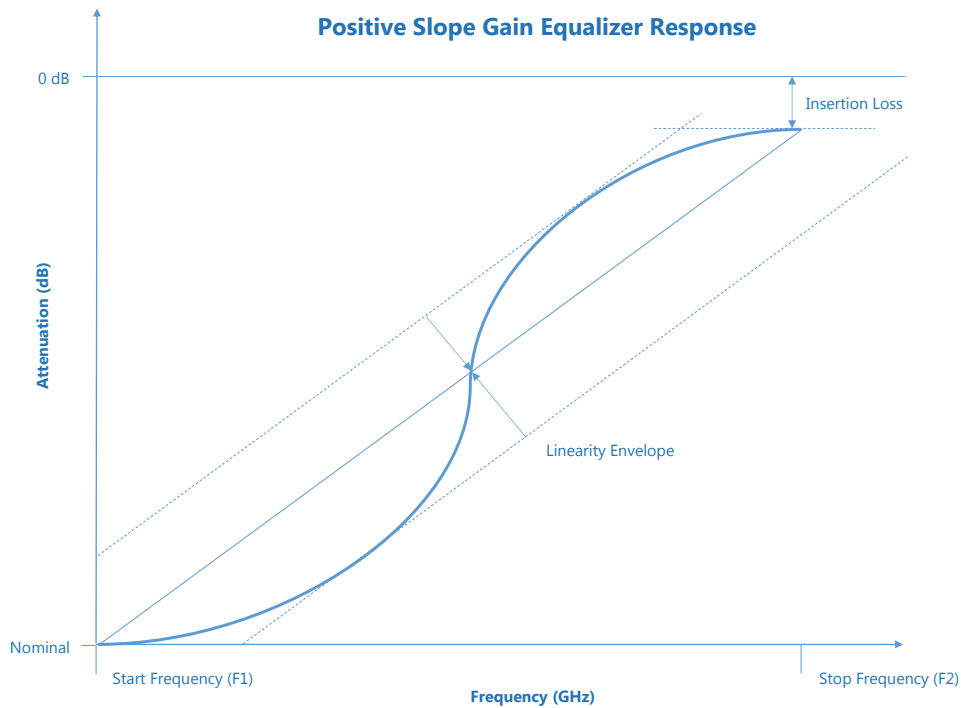

Available Values

Standard Equalizer Values

Part Number	SLOPE (dB) Negative	Part Mark Code	Start Frequency (GHz)	Stop Frequency (GHz)	ΔF (GHz)
CE 1 015 P 029 SMTF	1	140	1.5	2.9	1.4
CE 1 015 P 035 SMTF	1	130	1.5	3.5	2
CE 1 020 P 040 SMTF	1	127	2	4	2
CE 1 025 P 045 SMTF	1	125	2.5	4.5	2
CE 1 030 P 055 SMTF	1	120	3	5.5	2.5
CE 1 035 P 070 SMTF	1	115	3.5	7	3.5
CE 1 040 P 075 SMTF	1	112	4	7.5	3.5
CE 1 050 P 095 SMTF	1	110	5	9.5	4.5
CE 2 007 P 028 SMTF	2	240	0.7	2.8	2.1
CE 2 010 P 030 SMTF	2	235	1	3	2
CE 2 010 P 035 SMTF	2	230	1	3.5	2.5
CE 2 010 P 040 SMTF	2	227	1	4	3
CE 2 015 P 045 SMTF	2	225	1.5	4.5	3
CE 2 020 P 055 SMTF	2	220	2	5.5	3.5
CE 2 020 P 065 SMTF	2	215	2	6.5	4.5
CE 2 025 P 070 SMTF	2	212	2.5	7	4.5
CE 2 030 P 090 SMTF	2	210	3	9	6
CE 3 005 P 027 SMTF	3	340	0.5	2.7	2.2
CE 3 008 P 035 SMTF	3	330	0.8	3.5	2.7
CE 3 010 P 030 SMTF	3	332	1	3	2
CE 3 010 P 040 SMTF	3	327	1	4	3
CE 3 010 P 045 SMTF	3	325	1	4.5	3.5
CE 3 015 P 055 SMTF	3	320	1.5	5.5	4
CE 3 015 P 065 SMTF	3	315	1.5	6.5	5
CE 3 015 P 070 SMTF	3	312	1.5	7	5.5
CE 3 020 P 090 SMTF	3	310	2	9	7
CE 4 010 P 030 SMTF	4	426	1	3	2
CE 3 005 N 027 SMTF	3	340	0.5	2.7	2.2

High Frequency Equalizer Values

CEHF 1 170 P 220 SMTF	1	N/A	17	22	5
CEHF 3 170 P 220 SMTF	3	N/A	17	22	5
CEHF 1 270 P 320 SMTF	1	N/A	27	32	5
CEHF 3 270 P 320 SMTF	3	N/A	27	32	5

Power Derating Curve

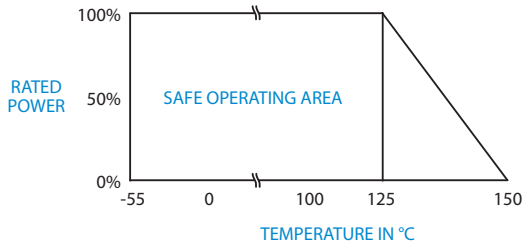

Typical Data

High Frequency Chip Equalizer Band 1

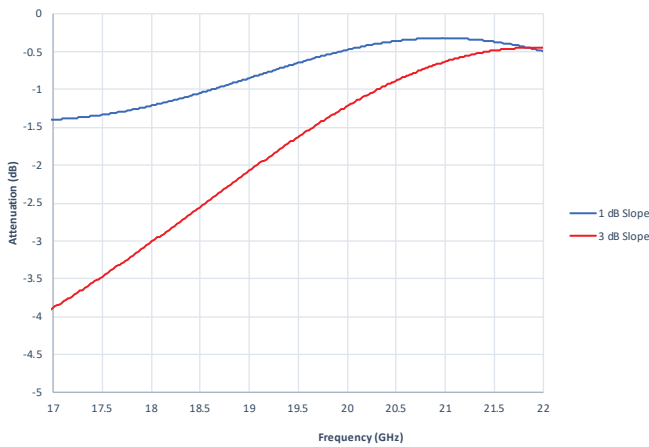

High Frequency Chip Equalizer Band 3

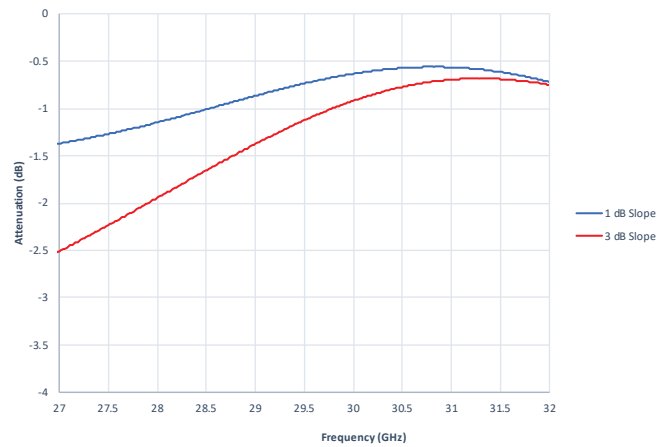

Mechanical

Standard Series

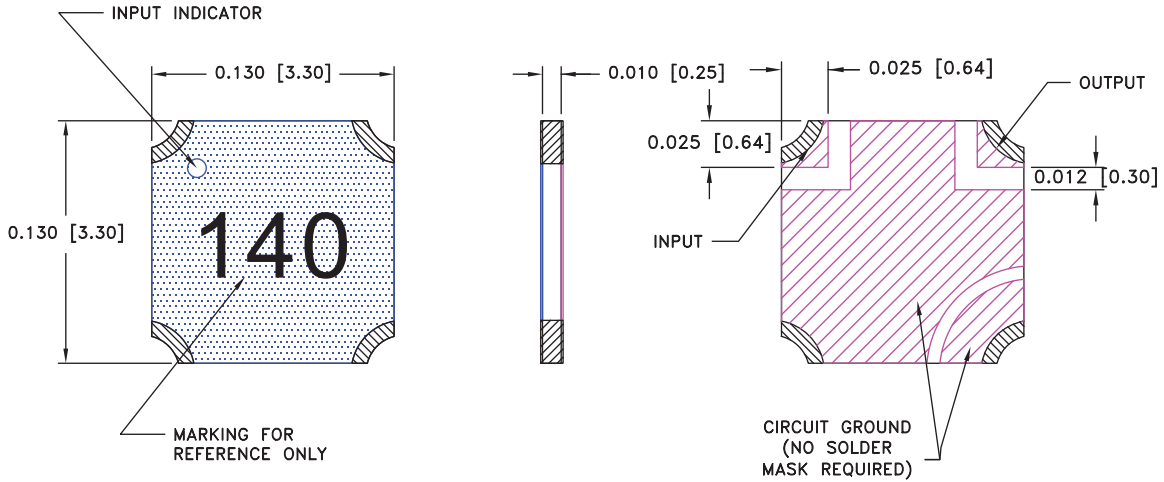

High Frequency Band 1 Series

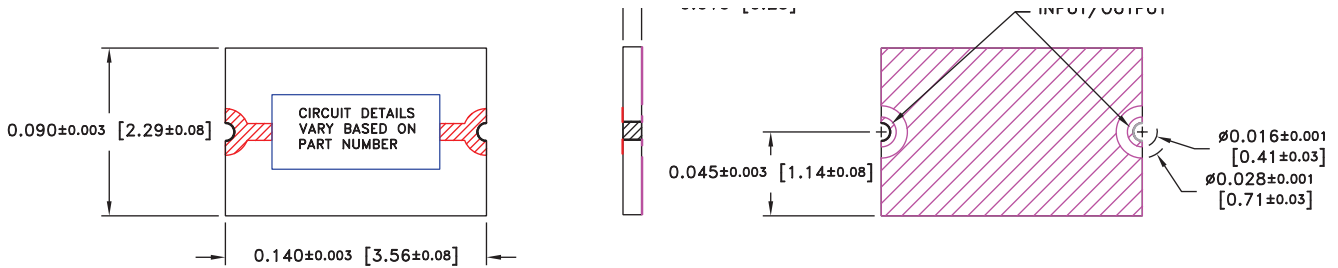

High Frequency Band 3 Series

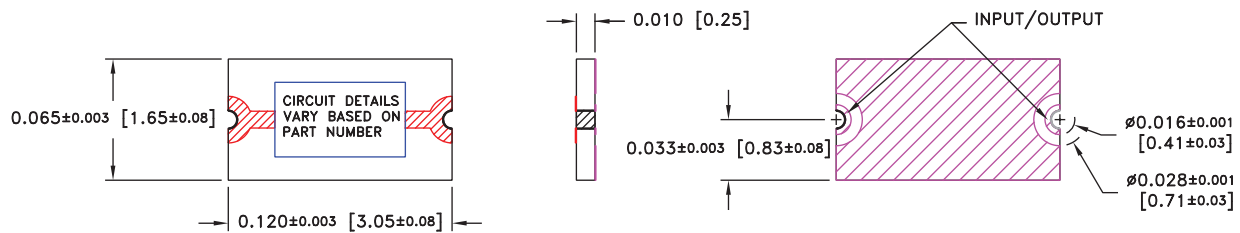

Suggested Mounting Footprint

Part Number	Inches						Millimeters					
	A	B	C	D	E	W	A	B	C	D	E	W
CEXXXXXXXXSMTF	0.030	0.030	0.012	0.056	0.093	0.140	0.76	0.76	0.30	1.42	2.36	3.56

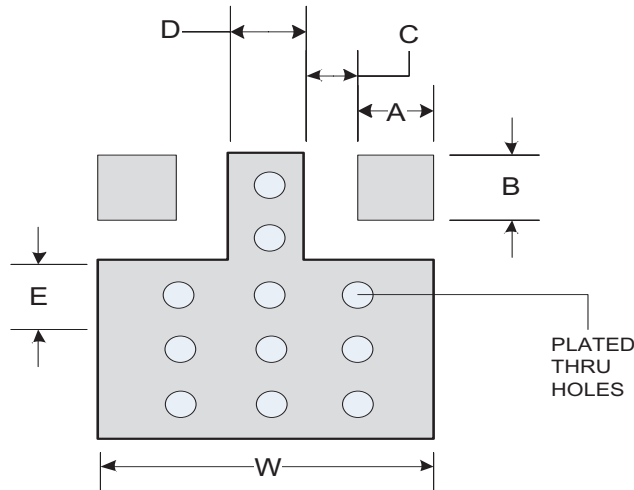

Part Number	Inches	Millimeters
	A	A
CEHFX170X220SMTF (17-22 GHz)	0.140	3.56
CEHFX270X320SMTF (27-32 GHz)	0.120	3.05

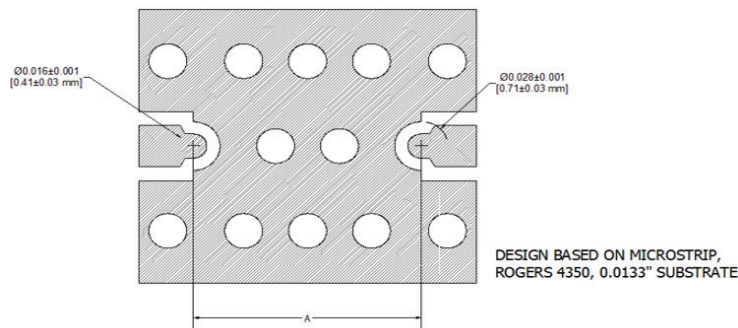

How To Order

Specify Model Number: **CE XX X XXX X XXX SMTF**

	C E						S M T	F
	1	2	3	4	5	6	7	8
1 Series Name	C E Series							
2 Frequency		Standard		H F High Frequency				
3 Slope			dB					
4 Start Frequency F1				(XX.X GHz)				
5 Slope Direction		N Negative		P Positive				
6 Stop Frequency F2				(XX.X GHz)				
7 SMT						S M T Surface Mount		
8 Terminal Finish								F RoHS Compliant

Worldwide Support

Connectors

Americas

Sales

connectors.uscsr@smithsinterconnect.com

Technical Support

connectors.ustechsupport@smithsinterconnect.com

Europe

Sales

connectors.emeacsr@smithsinterconnect.com

Technical Support

connectors.emeatechsupport@smithsinterconnect.com

Asia

Sales

asiacsr@smithsinterconnect.com

Technical Support

asiatechsupport@smithsinterconnect.com

Fibre Optics & RF Components

Americas

Sales

focom.uscsr@smithsinterconnect.com

Technical Support

focom.techsupport@smithsinterconnect.com

Europe

Sales

focom.emeacsr@smithsinterconnect.com

Technical Support

focom.techsupport@smithsinterconnect.com

Asia

Sales

focom.asiacsr@smithsinterconnect.com

Technical Support

focom.techsupport@smithsinterconnect.com

Semiconductor Test

Americas

Sales

semi.uscsr@smithsinterconnect.com

Technical Support

semi.techsupport@smithsinterconnect.com

Europe

Sales

semi.emeacsr@smithsinterconnect.com

Technical Support

semi.techsupport@smithsinterconnect.com

Asia

Sales

semi.asiacsr@smithsinterconnect.com

Technical Support

semi.techsupport@smithsinterconnect.com

RF/MW Subsystems

Americas, Europe & Asia

Sales

subsystems.csr@smithsinterconnect.com

Technical Support

subsystems.techsupport@smithsinterconnect.com

Connecting Global Markets

more > [smithsinterconnect.com](https://www.smithsinterconnect.com) | [in](#) [X](#) [▶](#)