

# Wiring Instructions

## Wiring instructions for Cat6a H and L modules

Revision E, 07/06/2024



# General Instructions

- Our Cat6a module for H or L series is specified for cables with 4 pairs UTP, STP, S/UTP, S/STP, and S/FTP for data and with outer diameter from 4,50 mm to 9,00 mm.
- The contact is equipped with 8x inner contacts Ø0.5mm crimping termination AWG 26-22.
- Wiring instructions are the same for H and L modules and for male and female modules.
- 1 - Tooling: page 3.
- 2 - Wiring instruction for standard version: page 4 to 10.
- 3 - Wiring instruction for low profile version: page 11 to 17.

# Tooling



Wire cutter



Cable jacket stripping



M22520/2-01  
AFM8 (DMC P/N)



ADJ. POSITIONER  
SK2/2 (DMC P/N)



Professional electrician scissors



Adjustable torque wrench  
Capacity 0-5N.m with drive size SW18



Adjustable Face Pin Wrench Set with pin Ø2mm  
(lower version)

# Wiring instruction for standard version: Overall Dimension of High-Speed Contacts Cat.6a

## H--18X1120GBM - MALE MODULE CAT6A – STANDARD VERSION FOR CABLE FROM Ø4.5MM TO Ø9MM

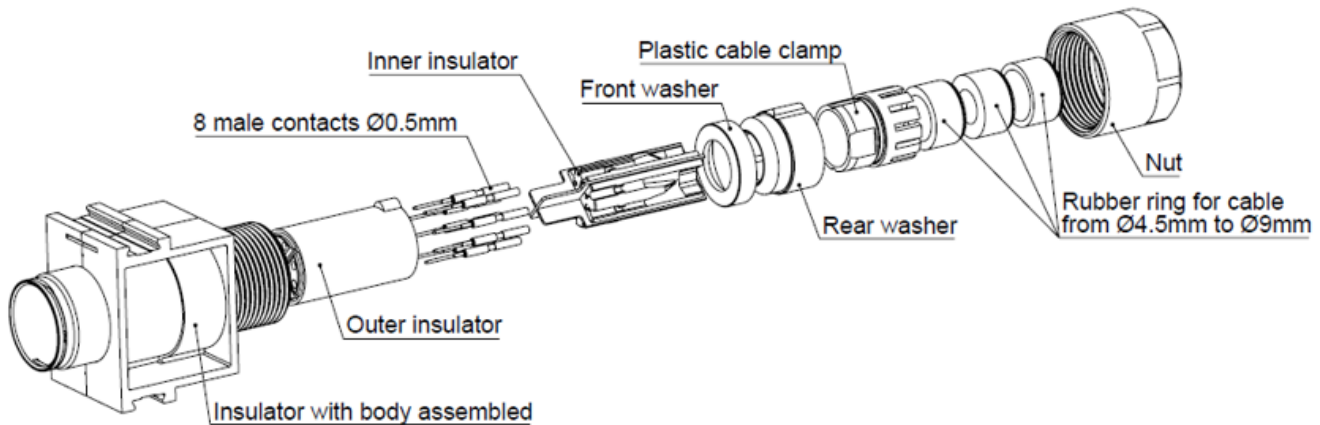
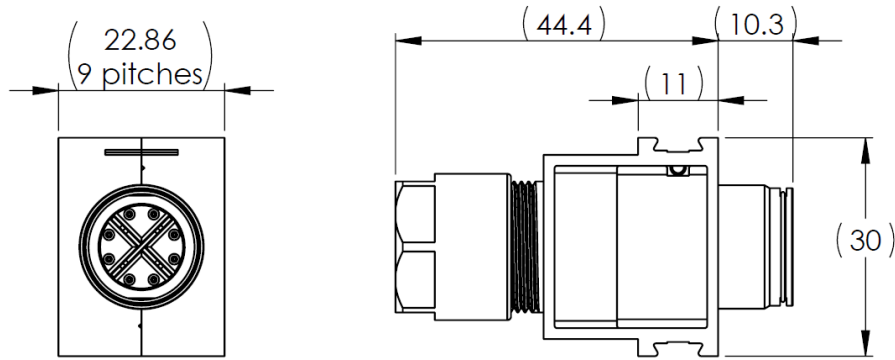

H--18X2020GBF - FEMALE MODULE CAT6A – STANDARD VERSION FOR CABLE FROM Ø4.5MM TO Ø9MM

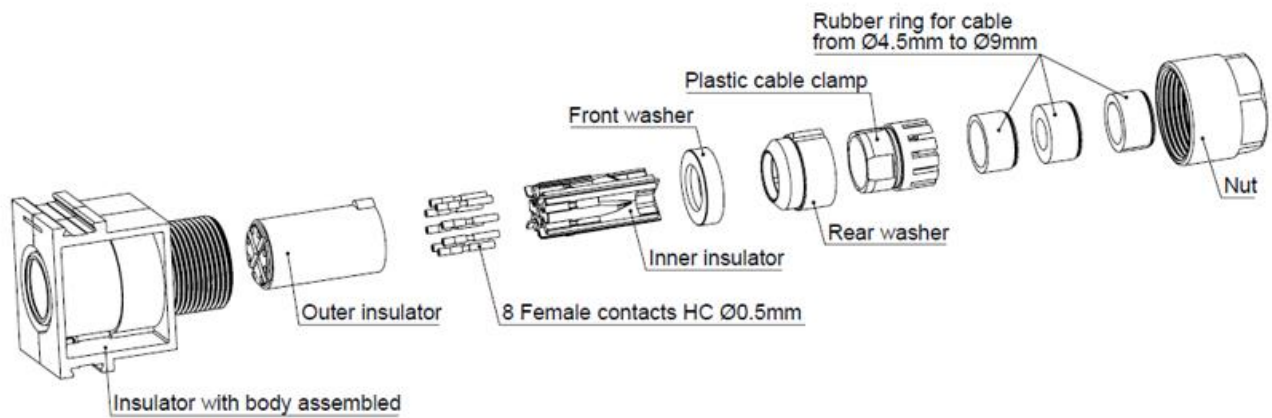
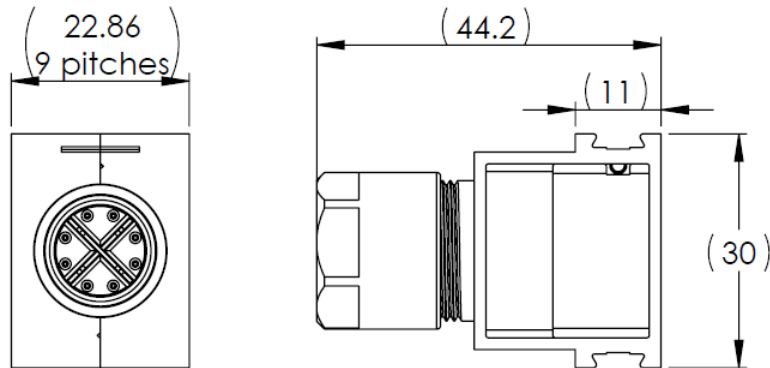

LC6AMRSVTH- MALE MODULE CAT6A – STANDARD VERSION FOR CABLE FROM Ø4.5MM TO Ø9MM

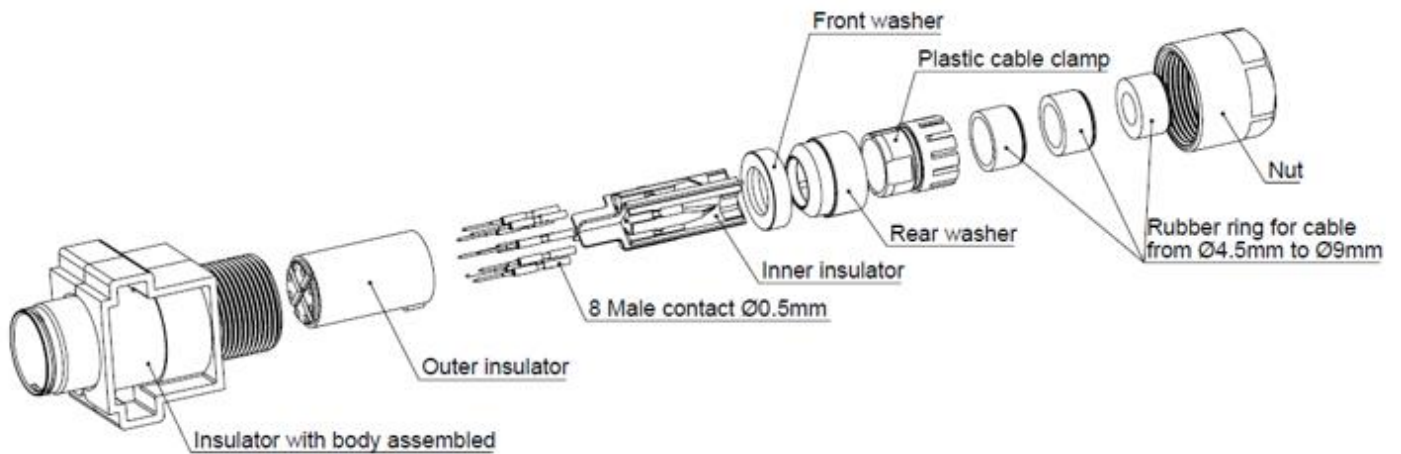
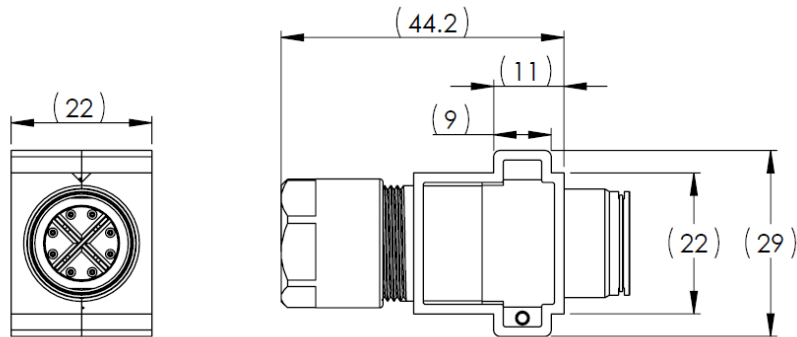

LC6AFRSVTAH- FEMALE MODULE CAT6A – STANDARD VERSION FOR CABLE FROM Ø4.5MM TO Ø9MM

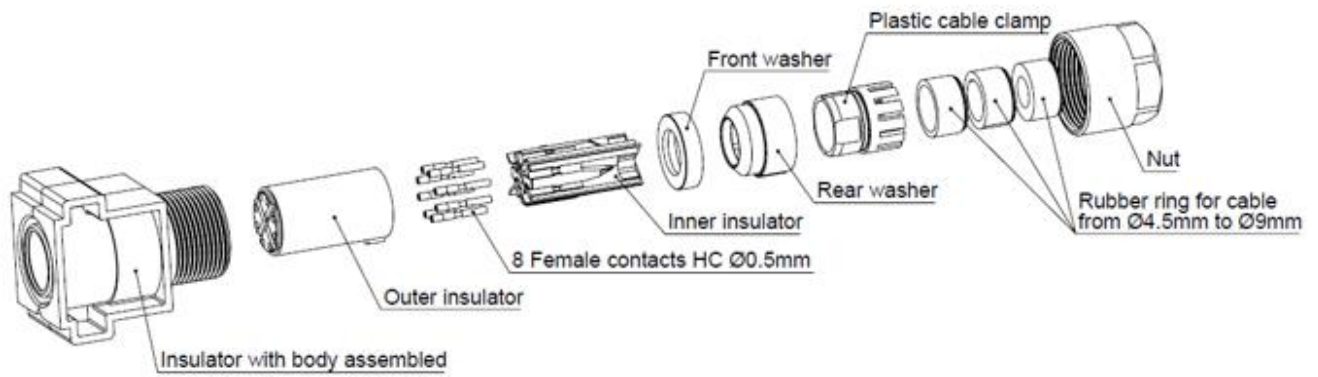
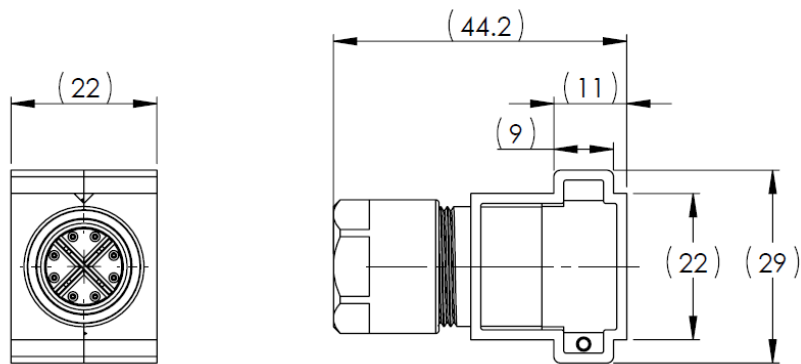

# Cat6a wiring instructions – Standard version

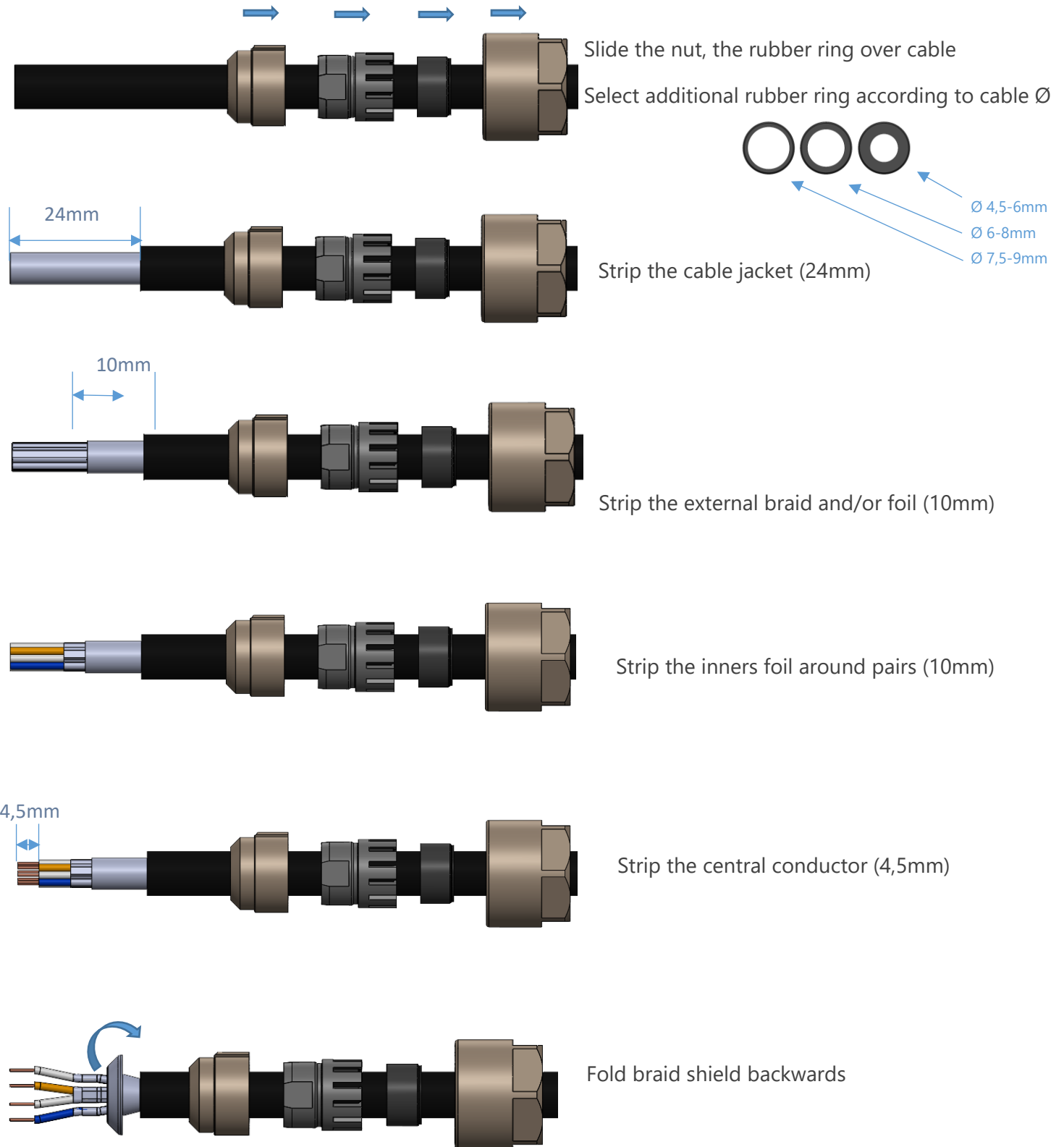

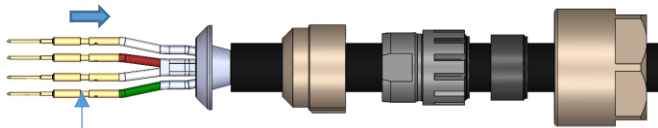

Wires must be visible in the sight hole before and after crimping

Crimp the contacts over cable center conductor by crimping tool.

Crimping tool		
Crimping tool	Turret tool	Selector position and wire cross section
M22520 / 2-01 AFM8 (DMC P/N)	ADJ. POSITIONER SK2/2 (DMC P/N)	3 - 0.079mm <sup>2</sup> (AWG28) 4 - 0.14 to 0.20 mm <sup>2</sup> (AWG26 - AWG24) 5 - 0.34mm <sup>2</sup> (AWG22)

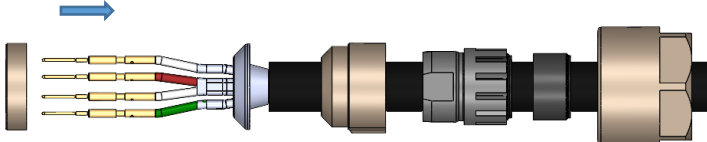

Slide the female conical washer and cut the braid in excess and crimp the contacts.

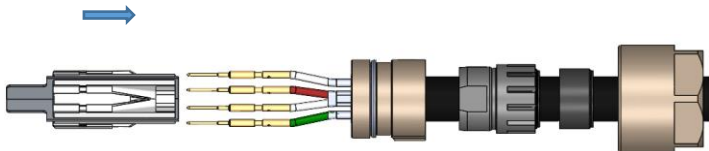
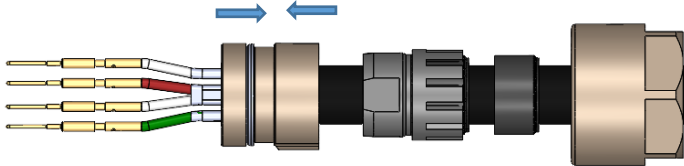

Slide the inner insulator

Easy assembly without specific tool.

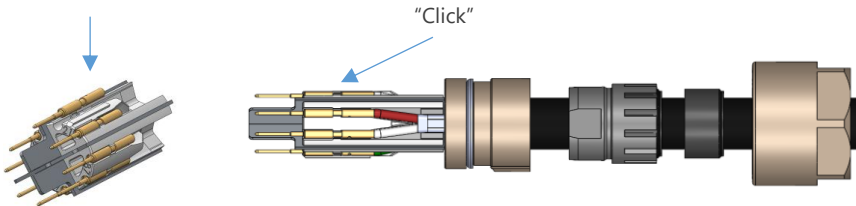

Clip the contacts on the insulator by the side. (no tool needed)

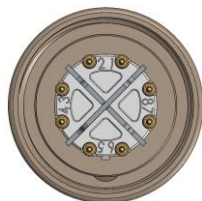

- 1 - White / Orange
- 2 - Orange
- 3 - White / Green
- 4 - Green
- 5 - White / Brown
- 6 - Brown
- 7 - White / Blue
- 8 - Blue



Finalization of the assembly

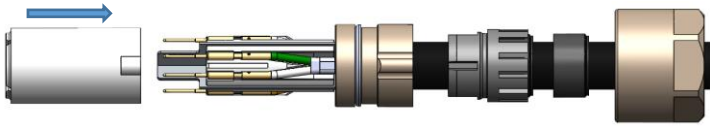

Align the outer insulator groove with groove inside the outer insulator

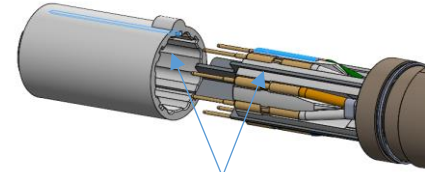

Slots should be aligned with locking feature.

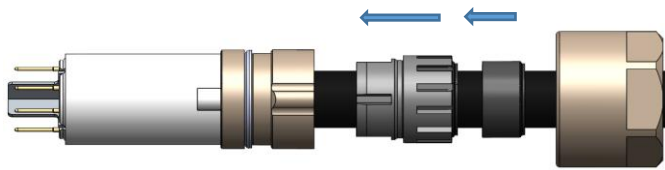

Slide the outer insulator

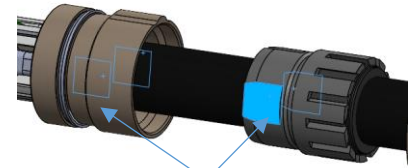

Slots should be aligned with locking feature.

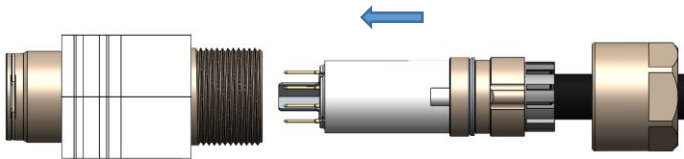

Align the outer insulator slot with groove inside the metal body.

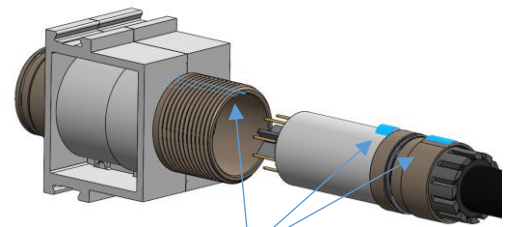

Slots should be aligned with locking feature.

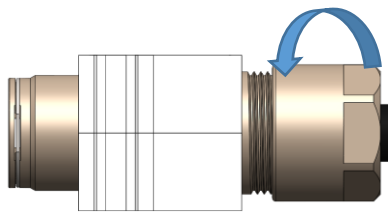

Tighten the metal nut.



SW18 1N.m

# Wiring instruction for low profile version: Overall Dimension of High Speed Contacts Cat.6a

H--18X1120GCM - MALE MODULE CAT6A – LOW PROFILE VERSION FOR CABLE FROM Ø4.5MM TO Ø9MM

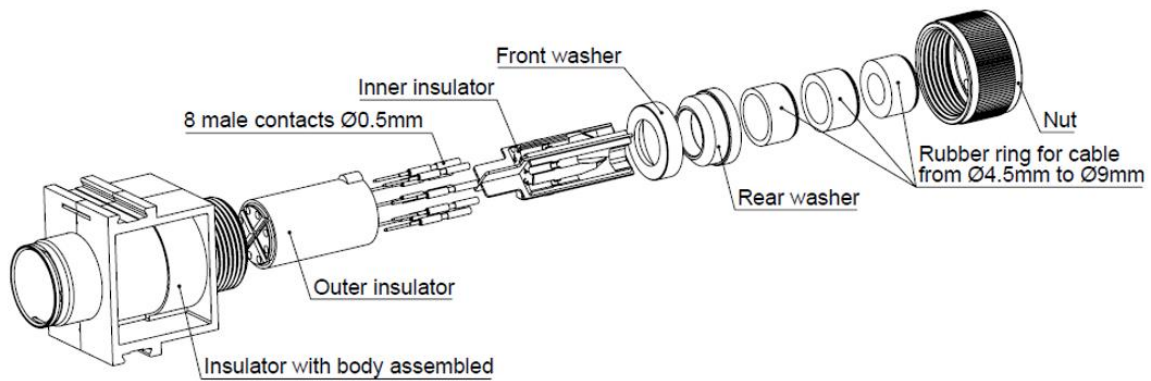
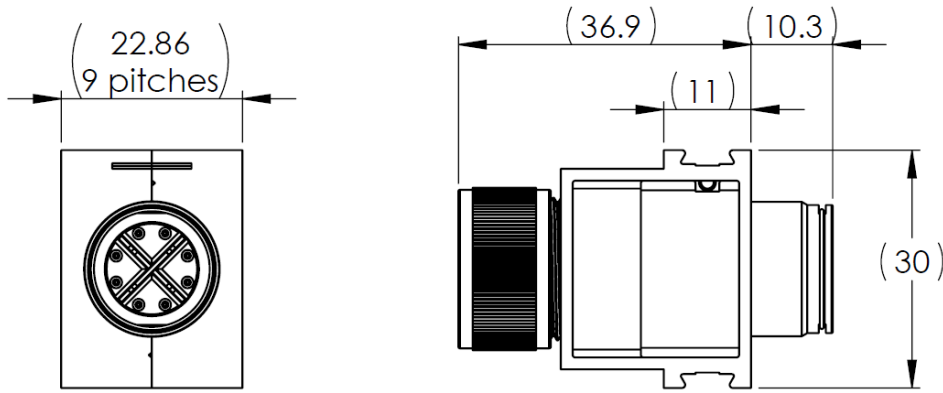

H--18X2020GCF - FEMALE MODULE CAT6A – LOW PROFILE VERSION FOR CABLE FROM Ø4.5MM TO Ø9MM

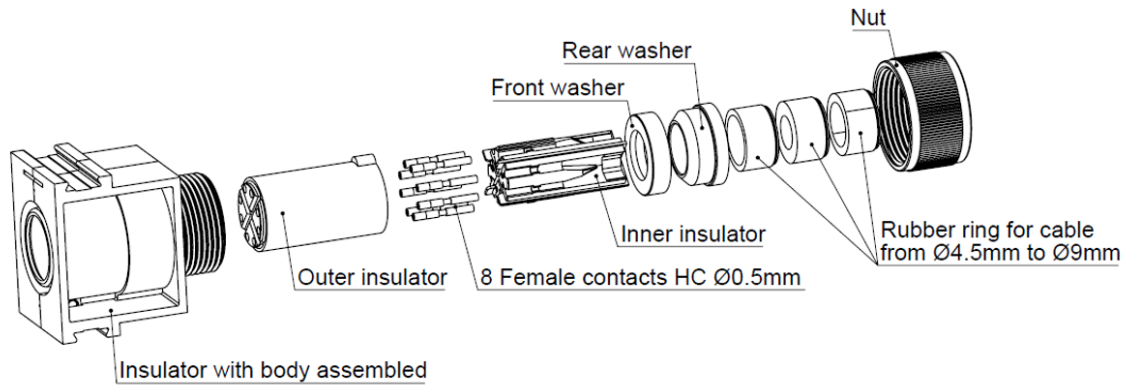
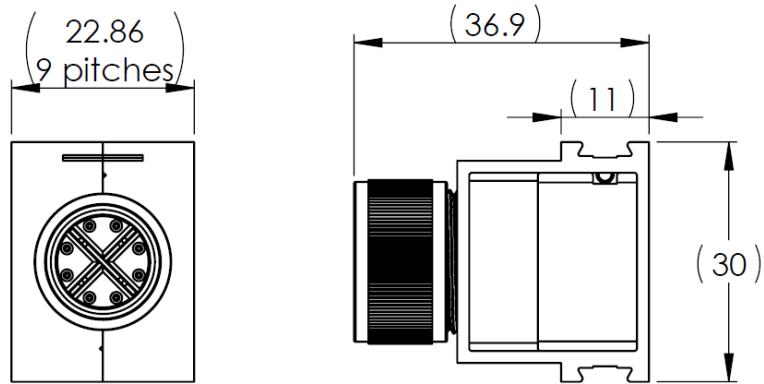

LC6AMRLPTH- MALE MODULE CAT6A – LOW PROFILE VERSION FOR CABLE FROM Ø4.5MM TO Ø9MM

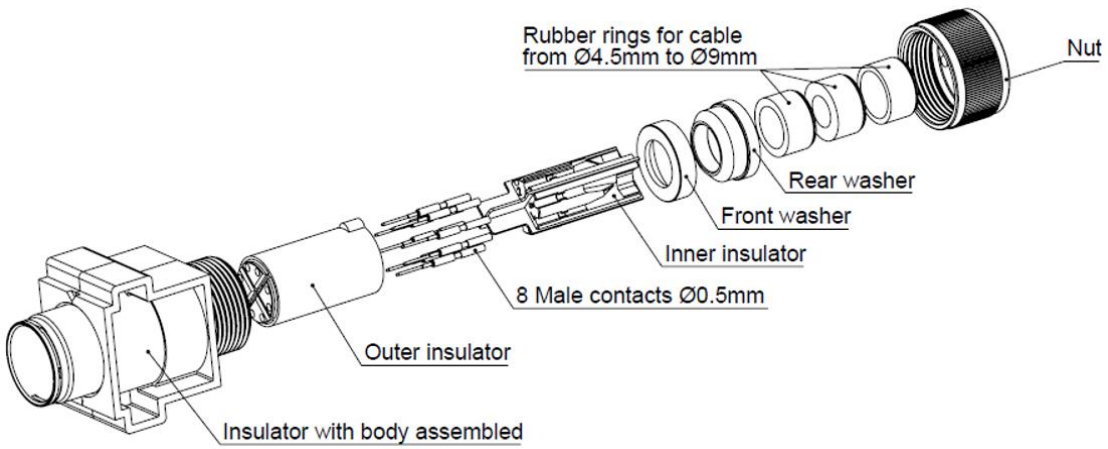
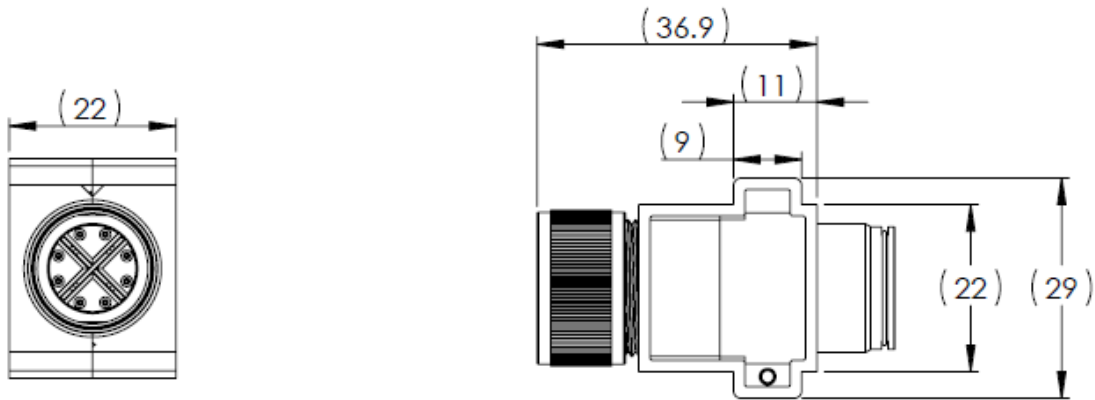

LC6AFRLPTAH- FEMALE MODULE CAT6A – LOW PROFILE VERSION FOR CABLE FROM Ø4.5MM TO Ø9MM.

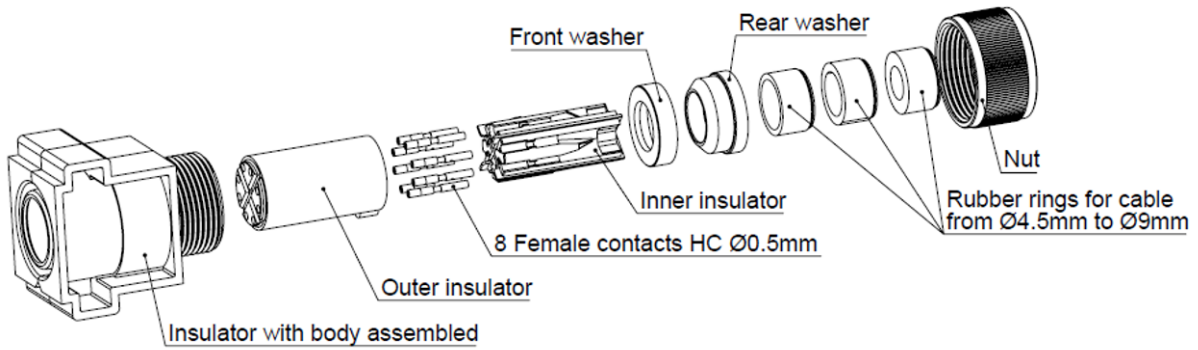
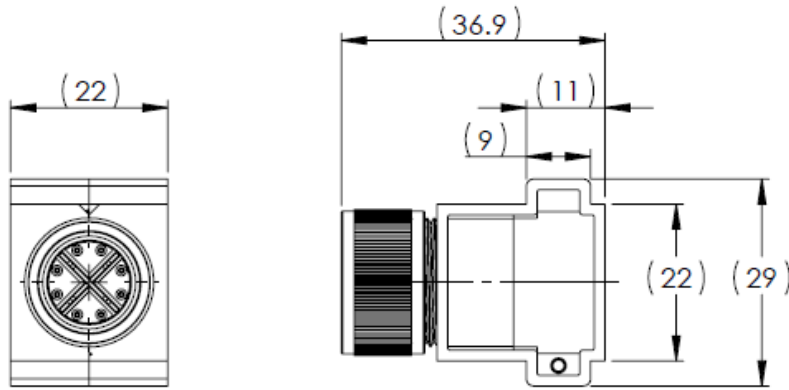

## Wiring instruction for low profile version

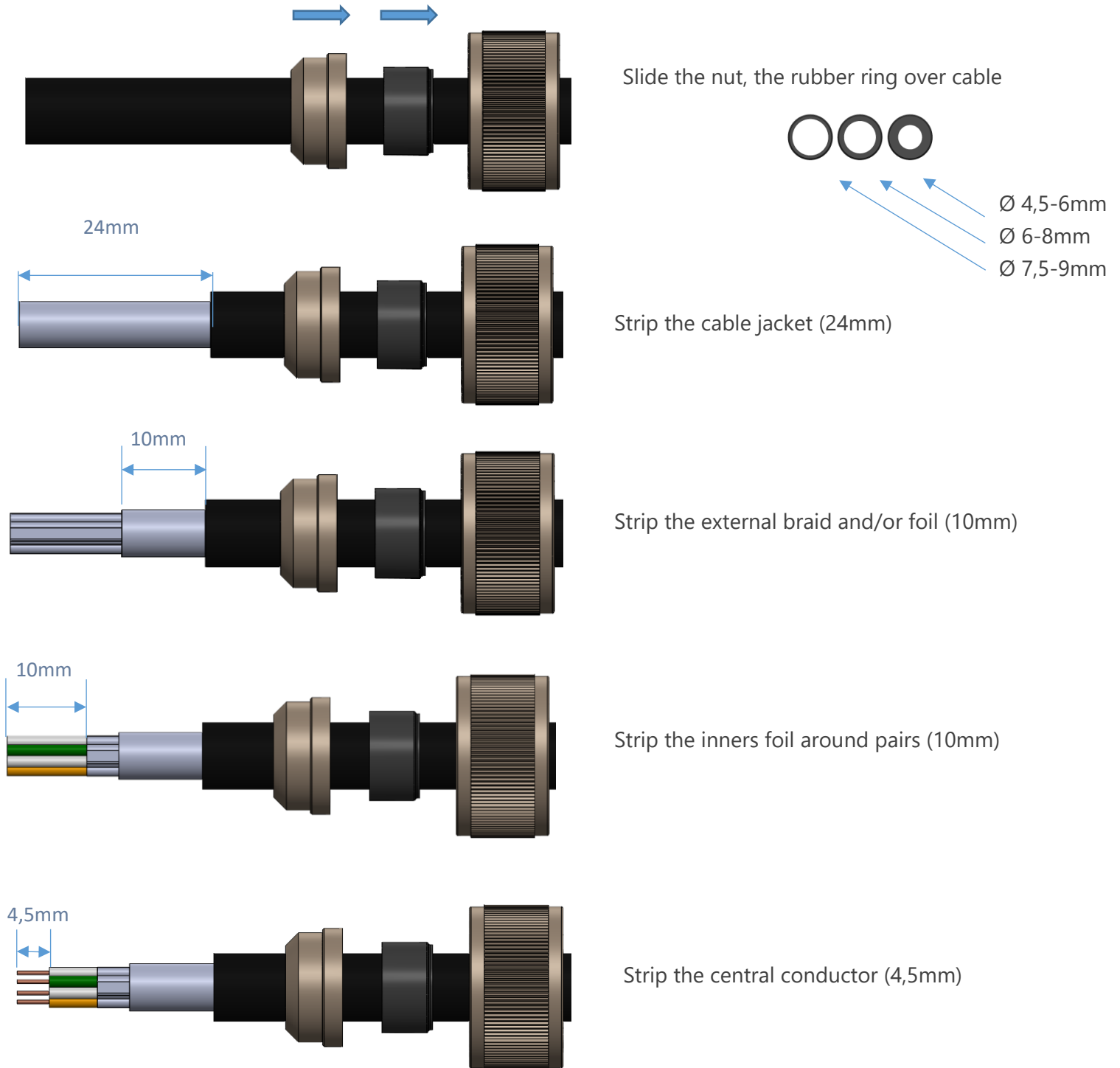

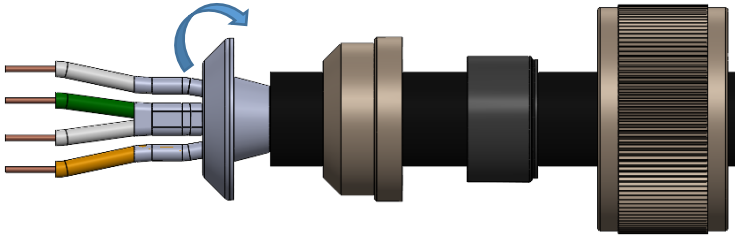

Strip the inners foil around pairs (10mm)

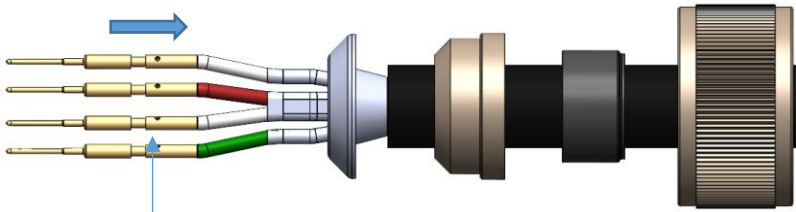

Crimp the contacts over cable center conductor by crimping tool

Wires must be visible in the sight hole before and after crimping

Crimping tool		
Crimping tool	Turret tool	Selector position and wire cross section
M22520 / 2-01 AFM8 (DMC P/N)	ADJ. POSITIONER SK2/2 (DMC P/N)	3 - 0.079mm <sup>2</sup> (AWG28) 4 - 0.14 to 0.20 mm <sup>2</sup> (AWG26 - AWG24) 5 - 0.34mm <sup>2</sup> (AWG22)

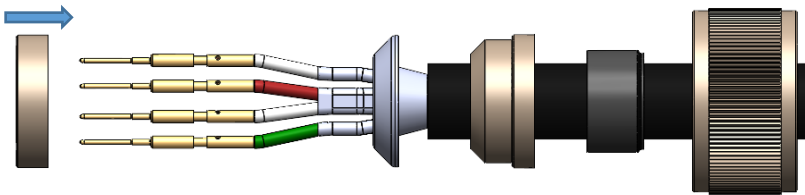

Slide the female conical washer and cut the braid in excess and crimp the contacts.

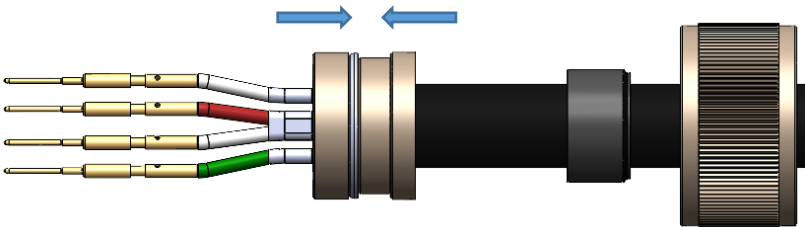

Slide the inner insulator

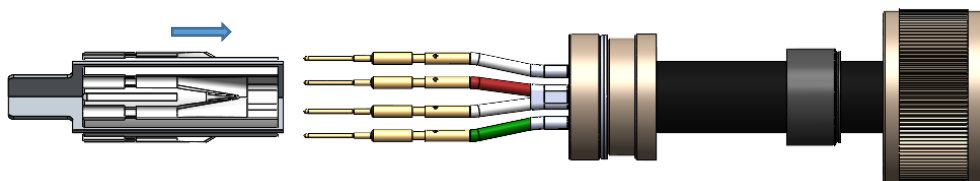

Easy assembly without specific tool.

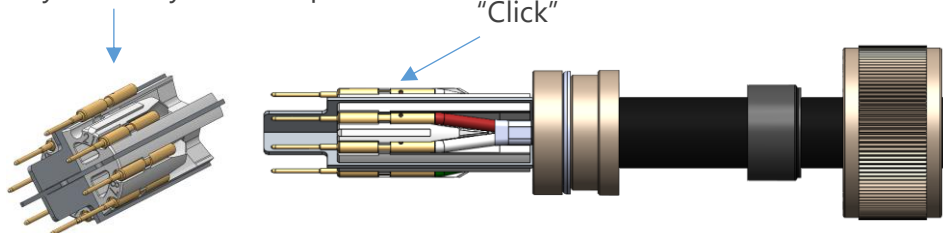

Clip the contacts on the insulator by the side (no tool needed)

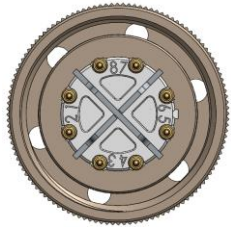

- 1 – White / Orange
- 2 – Orange
- 3 – White / Green
- 4 – Green
- 5 – White / Brown
- 6 – Brown
- 7 – White / Blue
- 8 – Blue



**Finalization of the assembly**

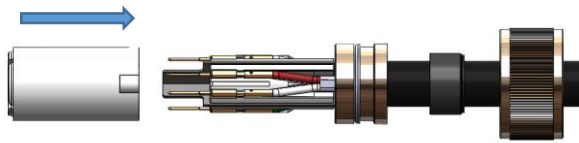

Align the outer insulator groove with groove inside the outer insulator

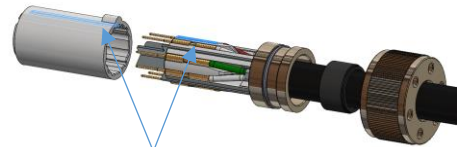

Slots should be aligned with locking feature.

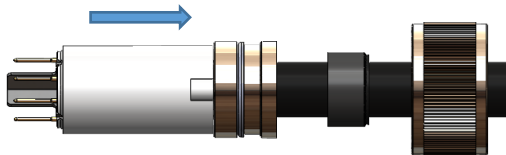

Slide the outer insulator

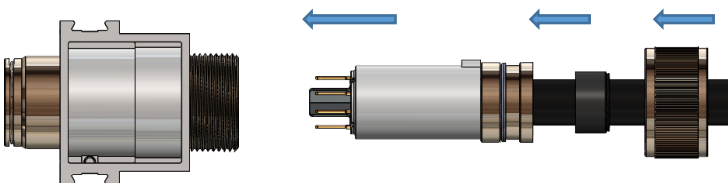

Align the outer insulator slot with groove inside the metal body.

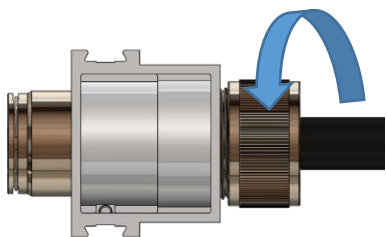

Tighten the metal nut.

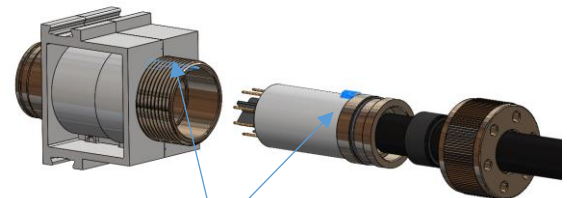

Slots should be aligned with locking feature.