

# D-Series H-Pin Socket

Accelerated life testing solution

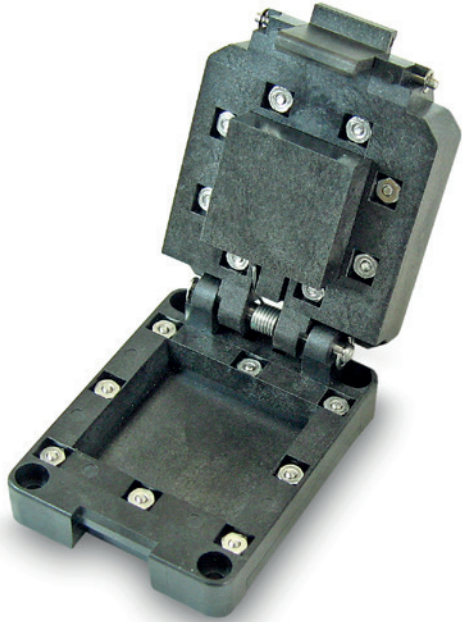

**D-Series Socket is a performance burn-in socket, with a clamshell-style lid that can be equipped with a heater and thermal sensor.**

The D-Series line shares the same configurable features as other socket series in the Smiths Interconnect burn-in test portfolio.

Leveraging H-Pin™ technology the D-Series line provides market-leading electrical performance, for high-speed burn-in applications.

Burn-in sockets using H-Pin technology for high-reliability testing of next-generation IC packages

## Benefits

- Design flexibility, in-house tooling and molds allow for the lowest cost of test.
- Extensive catalog of components and configurable options
- Proven track record of reducing the cost of test leveraging modular components, automated assembly, and short lead times.
- Exceptional electrical performance providing wide RF bandwidth.

## Feature options

- For QFN, QFP, LCC, SOIC, BGA, and LGA
- Spring loaded plunger
- Heat sink
- HAST venting features
- Integrated thermal control with heater and sensor.
- Reverse seating plane
- High temperature materials for above 200 °C applications

## D-Series socket specifications

### Mechanical properties

- **Pitch:**  $\geq 0.30$  mm
- **Package size:**
  - LGA: 2 mm to 25 mm
  - BGA: 2 mm to 20 mm
- **Pin count:** 1570
- **Temperature:**  $-55^{\circ}\text{C}$  to  $260^{\circ}\text{C}$

### Electrical properties

- **Contact resistance:** 35 m $\Omega$
- **Current carrying capacity:** up to 4 A

### Materials

- **Contact:** BeCu/Au plated
- **Spring:** SS/Au plated
- **Socket:** Engineering plastics

## D-Series socket dimensions

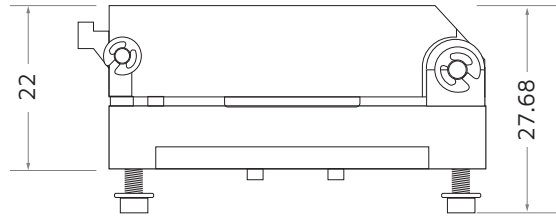
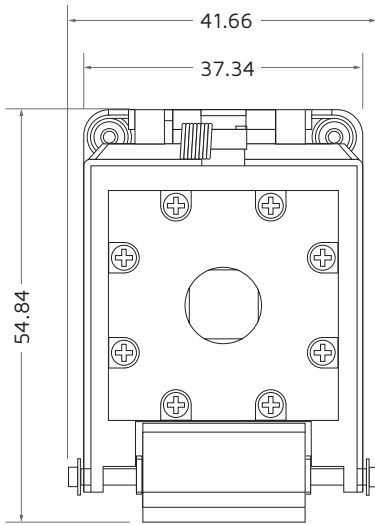

Dimensions are in mm.

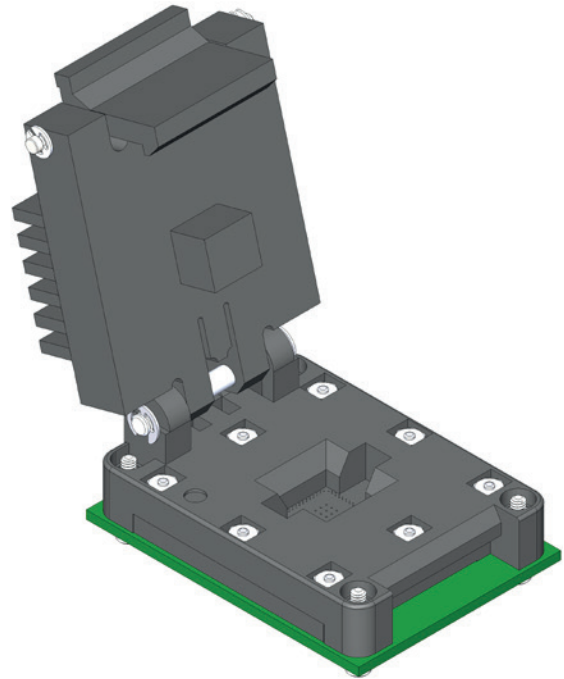
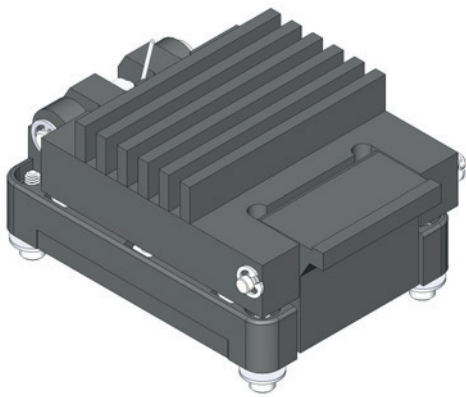

more > [smithsinterconnect.com](https://smithsinterconnect.com) | [in](#) [t](#) [v](#)