

HC Series Attenuators and Thermopads®

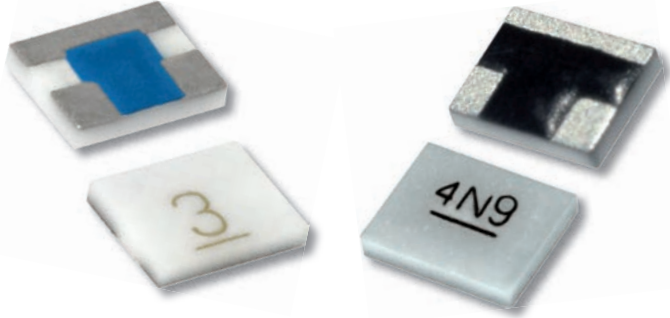

In response to the raising demand of the commercial space programs - and in particular of GEO/MEO and LEO satellites - for high-reliability connectivity solutions, Smiths Interconnect has introduced SpaceNXT™, the new range of COTS+ platform products specifically designed and tested for critical space flight applications.

The SpaceNXT™ HC Series are temperature variable and fixed chip attenuators offering a high volume solution that leverages the company's space heritage with improved performance over a QPL or traditional COTS product. Available from a standard part list that eliminates the need for time-consuming drawings and specifications, the HC Series provides an easy-to-use and and cost effective solution with proven mission assurance. This solution is also well suited for military and aerospace applications.

The HC series offers the addition of 100% flight product testing to Group A for mission assurance. Options for group B and C testing are also available to further and completely qualify the lot of product. All data is provided to the customer for compliance to specification and mission assurance.

The availability of fixed and Thermopad® attenuators in the same footprint gives the program ultimate design flexibility to tailor the response over variations in temperature. The Thermopad® compensates for gain variation over temperature and is a totally passive, surface mountable temperature variable attenuator. The Thermopad® can be used in place of a standard chip attenuator to combine level setting or buffering and temperature compensation in a single chip design. This reduces the component count, whilst increasing reliability and lowering costs.

The new fully tested solution is available in a planar version for the lowest cost option or in a triple wrapped series which gives the best visibility for inspection of the solder attachment. The products are delivered on standard tape and reel packaging to seamlessly integrate the customer's pick and place equipment and ensure an easy installation.

High reliability attenuators specifically designed and tested for next generation commercial space applications

Features & Benefits

- Temperature variable and fixed attenuator for design flexibility
- 100% flight test data
- Available lot qualification
- Small footprint
- Solderable surface mount
- Wide attenuation and TCA shifts available
- Ease of installation
- Totally passive solution

Applications

- Satellite communications
- Power amplifiers
- Up and down converters
- Transmitters and receivers
- Isolators/circulators
- Instrumentation
- Mixers
- Directional couplers

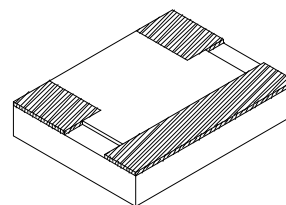

Planar Termination

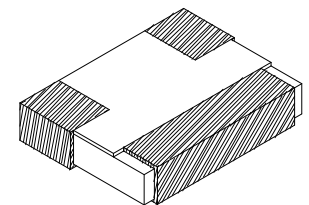

Triple Wrap Termination

HC05 Series

Fixed Attenuators

Technical Characteristics

Electrical

Nominal Impedance	50 ohms																																											
Frequency Range	DC - 12.4 GHz [*18 GHz for S option]																																											
Attenuation Values Available	0 - 20 in 1 dB increments																																											
Attenuation Accuracy	<table border="1"> <thead> <tr> <th colspan="5">ATTENUATION ACCURACY</th> </tr> <tr> <th>dB</th> <th>DC - 4 GHz</th> <th>4 - 8 GHz</th> <th>8 - 12.4 GHz</th> <th>12.4 - 18 GHz*</th> </tr> </thead> <tbody> <tr> <td>0</td> <td>-0,+.3</td> <td>-0,+.5</td> <td>-0,+.5</td> <td>-0,+.5</td> </tr> <tr> <td>1 - 3</td> <td>±0.3</td> <td>±0.5</td> <td>±0.5</td> <td>±0.5</td> </tr> <tr> <td>4 - 6</td> <td>±0.4</td> <td>±0.5</td> <td>±0.5</td> <td>±0.75</td> </tr> <tr> <td>7 - 10</td> <td>±0.5</td> <td>±0.5</td> <td>±0.75</td> <td>±1.0</td> </tr> <tr> <td>11 - 15</td> <td>±0.75</td> <td>+0.5,-3.0</td> <td>+0.5,-3.5</td> <td>---</td> </tr> <tr> <td>16 - 20</td> <td>±1.0</td> <td>+0.5,-4.0</td> <td>+1.0,-6.0</td> <td>---</td> </tr> </tbody> </table>				ATTENUATION ACCURACY					dB	DC - 4 GHz	4 - 8 GHz	8 - 12.4 GHz	12.4 - 18 GHz*	0	-0,+.3	-0,+.5	-0,+.5	-0,+.5	1 - 3	±0.3	±0.5	±0.5	±0.5	4 - 6	±0.4	±0.5	±0.5	±0.75	7 - 10	±0.5	±0.5	±0.75	±1.0	11 - 15	±0.75	+0.5,-3.0	+0.5,-3.5	---	16 - 20	±1.0	+0.5,-4.0	+1.0,-6.0	---
ATTENUATION ACCURACY																																												
dB	DC - 4 GHz	4 - 8 GHz	8 - 12.4 GHz	12.4 - 18 GHz*																																								
0	-0,+.3	-0,+.5	-0,+.5	-0,+.5																																								
1 - 3	±0.3	±0.5	±0.5	±0.5																																								
4 - 6	±0.4	±0.5	±0.5	±0.75																																								
7 - 10	±0.5	±0.5	±0.75	±1.0																																								
11 - 15	±0.75	+0.5,-3.0	+0.5,-3.5	---																																								
16 - 20	±1.0	+0.5,-4.0	+1.0,-6.0	---																																								
Input Power CW	100 Milliwatts max up to 125°C																																											
Peak Power	1 watt based on 10 us pulse width @ 1% duty cycle.																																											
VSWR	DC - 4 GHz	4 - 8 GHz	8 - 18 GHz																																									
	1.25 max	1.35 max	1.50 max																																									

Environmental

Operating Temperature	-55°C to +150°C
Storage Temperature	-65°C to +150°C
Moisture Sensitivity Level	MSL 1 - unlimited

Mechanical

Substrate Material	Alumina (Al ₂ O ₃) 96%
Resistive Film	Thin film, Tantalum Nitride
Terminal Material	Thick Film, Nickel Barrier, Solder Coated (Sn60/Pb40)
Protective Coating	Polymer

Marking

Unit Marking	Marked with dB value. Legibility and permanency PER MIL-STD-130
--------------	---

Quality Assurance

Test Plan	TP-9191
	100% Visual Pre-Cap Inspection Performed
	Group A, B and/or C testing as indicated by the part number
	Test Data Provided: 100% test data; Data retention - 24 months

Packaging

Standard Packaging	Tape and reel or serialized wafer pack
--------------------	--

Power Derating Curve

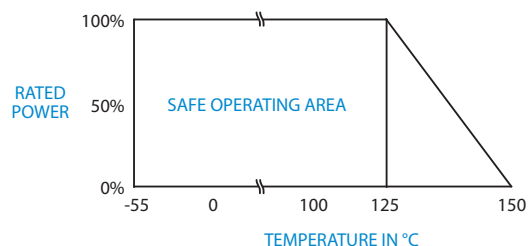

Typical Data

HC05XXS Series Attenuation

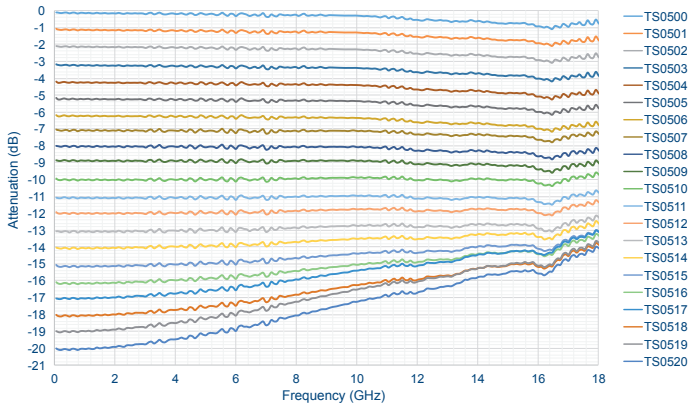

HC05XXW3S Series Attenuation

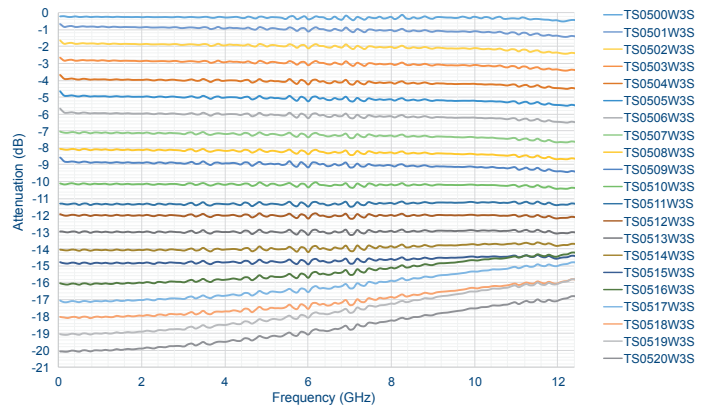

Mechanical

HC05XXXS

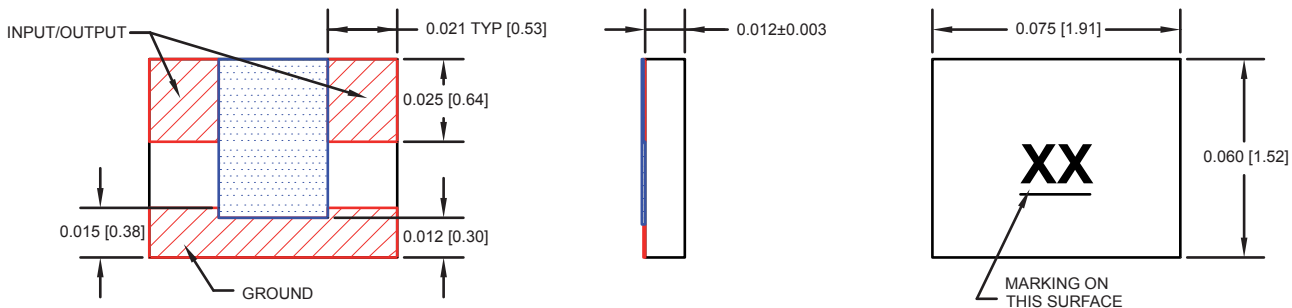

HC05XXXW3S

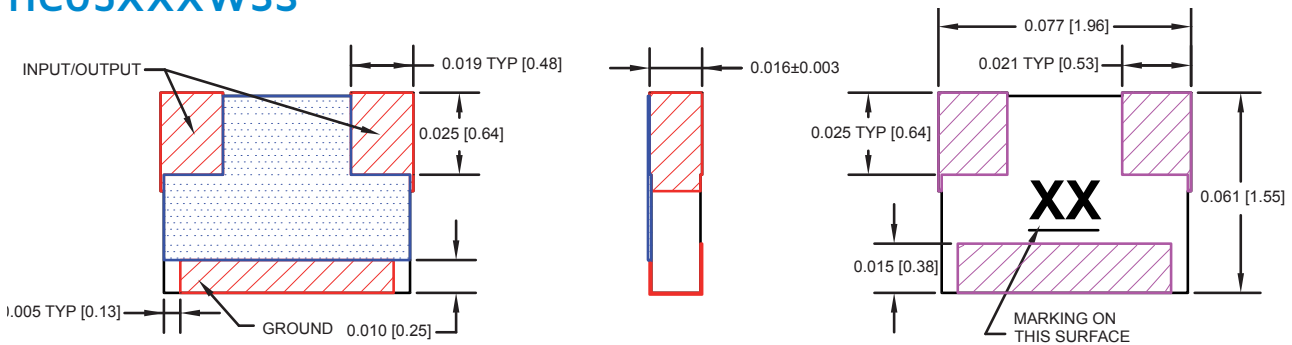

*Dimensions apply before solder. Allow 0.015 max for all pretinned surfaces.
Unless otherwise specified, tolerance: X.XXX = ±0.005

HCM Series

Thermopad® Temperature Variable Attenuators

Technical Characteristics

Electrical

	W3S option	S option
Nominal Impedance	50 ohms	
Frequency Range	DC - 12.4 GHz	-.003 dB/dB/ °C Thru -.005 dB/dB/ °C DC - 18 GHz -.006 dB/dB/ °C Thru -.009 dB/dB/ °C DC - 12.4 GHz
Attenuation Values Available	0 - 10 in 1 dB increments	
Attenuation Accuracy @25°C	±0.5 dB @ 1GHz	
VSWR	1.30:1 Max @ 1GHz	
Input Power	200 Milliwatts max up to 125°C	
Temperature Coefficient of Attenuation	-0.003, -0.004, -0.005, -0.006, -0.007, and -0.009 dB/dB/°C	
Temperature Coefficient Tolerance	±0.001 dB/dB/°C	

Environmental

Operating Temperature	-55°C to +150°C
Storage Temperature	-65°C to +150°C
Moisture Sensitivity Level	MSL 1 - unlimited

Mechanical

Substrate Material	Alumina (Al ₂ O ₃) 96%
Resistive Film	Thick film, Thermistor
Terminal Material	Thick film, Nickel Barrier, Solder Coated (Sn60/Pb40)
Protective Coating	Polymer

Marking

Unit Marking	dB value (X), Direction of Shift (N) and TCA Shift (X) Legibility and permanency per MIL-DTL-130
--------------	---

Quality Assurance

Test Plan	TP-9191
	100% Visual Pre-Cap Inspection Performed
	Perform Group A, B and/or C testing as indicated by the part number
	Test Data Provided: 100% test data; Data retention - 24 months

Packaging

Standard Packaging	Tape and reel or serialized wafer pack
--------------------	--

Power Derating Curve

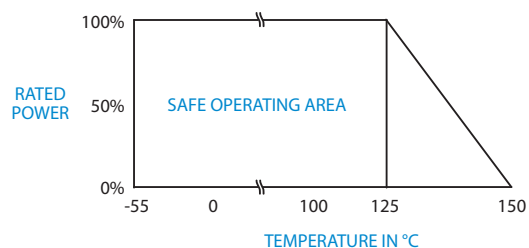

Typical Data

HCMXXXXXXS Series Attenuation

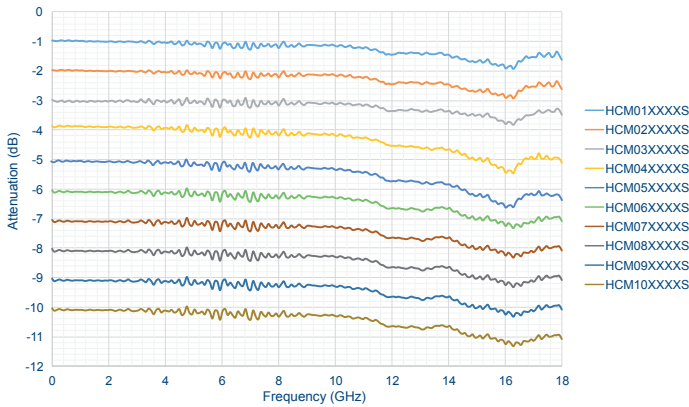

HCMXXXXXXW3S Series Attenuation

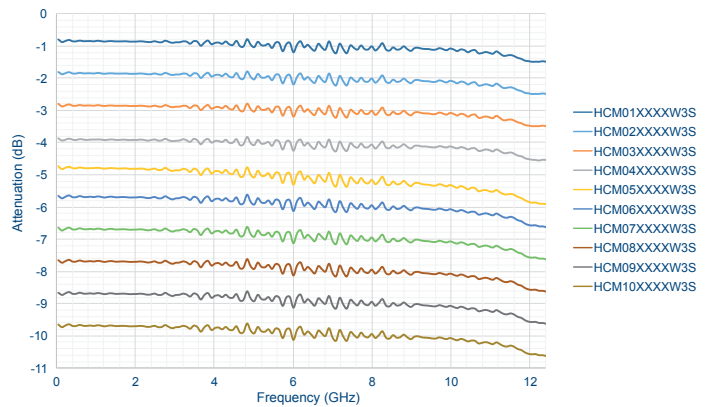

Mechanical

HCMXXXXXXS

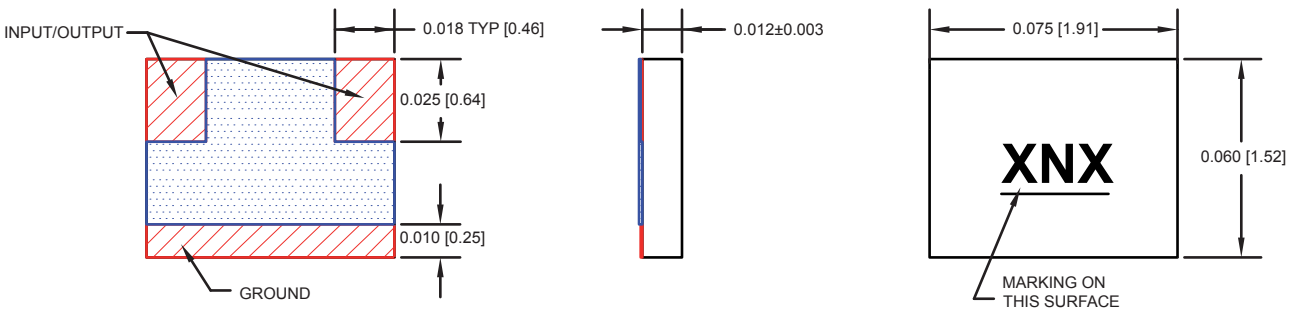

HCMXXXXXXW3S

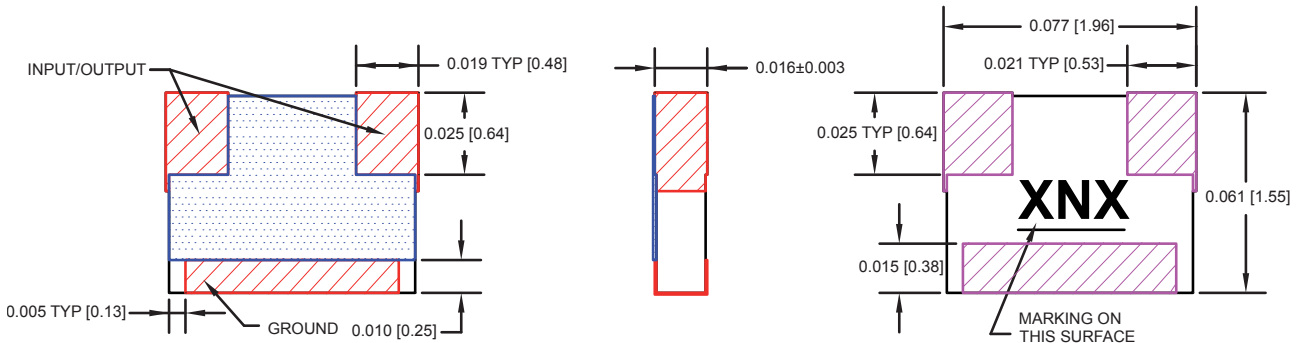

*Dimensions apply before solder. Allow 0.015 max for all pretinned surfaces. Unless otherwise specified, tolerance: X.XXX = ±0.005

HC Series Attenuators and Thermopads

Test Parameters per Test Plan TP-9191

Test	Sample Qty	Test Standard and Method	Test Condition
Pre-Cap Visual and Mechanical	100%	MIL-PRF-55342	30X to 60X Magnification
Group A Inspection			
Visual / Mechanical	100%	MIL-PRF-55342	30X to 60X Magnification
Thermal Shock	100%	MIL-PRF-55342, MIL-STD-202, Method 107	10 Cycles -55 to +125°C
Bake	100%	Per Smiths Interconnect TP-9191	96 hours @ 150°C
DC Attenuation	100%	MIL-PRF-55342, MIL-STD-202, Method 303	Tolerance per dB Value @25°C
Visual and Mechanical	100%	MIL-PRF-55342	30X to 60X Magnification
Group A Lot Qualification			
Visual and Mechanical	40	MIL-PRF-55342	30X to 60X Magnification
Initial Electrical (RF) Inspection	40	MIL-PRF-55342	VSWR @1.0 GHz and Attenuation @ DC & 1.0 GHz Limits per datasheet and dB Value
Thermal Shock	40	MIL-PRF-55342, MIL-STD-202, Method 107	10 Cycles -55 to +125°C
Burn In	40	MIL-PRF-55342, MIL-STD-202, Method 108	Maximum Rated Input Power @ 125°C for *Exception 168 Hours
Final Electrical (RF) Inspection	40	MIL-PRF-55342	VSWR @1.0 GHz and Attenuation @ DC & 1.0 GHz ±0.2 dB from Initial Electrical (RF) Inspection allowable
Percent Defective Allowable (PDA)	40	Per Smiths Interconnect TP-9191	10% allowable
Subgroup 1	3		
Temperature Coefficient of Attenuation TCA (If Temp Variable Product)	3	Per Smiths Interconnect TP-9191	-55°C to +125°C - ±0.001 dB/dB/°C allowable
Group B Inspection			
Subgroup 1	10		
Electrical (RF) Inspection	10	MIL-PRF-55342	VSWR @1.0 GHz and Attenuation @ DC & 1.0 GHz Limits per datasheet and dB Value
Low Temperature Operation	10	MIL-PRF-55342	Maximum Rated Input Power @ -55°C *Exception -55°C
Electrical (RF) Inspection	10	MIL-PRF-55342	VSWR @1.0 GHz and Attenuation @ DC & 1.0 GHz Limits per datasheet and dB Value
High Temperature Exposure	10	MIL-PRF-55342	100 hours @ *Exception 125°C
Electrical (RF) Inspection	10	MIL-PRF-55342	VSWR @1.0 GHz and Attenuation @ DC & 1.0 GHz Limits per datasheet and dB Value
Termination Adhesion	10	MIL-PRF-55342, MIL-STD-202, Method 211	Test Condition A - Pull Test - *Exception 15 Grams
Termination Solderability (Resistance to Soldering Heat)	10	MIL-PRF-55342, MIL-STD-202, Method 210	Test Condition B - Solder Dip - Sn/Pb 22-°C for 5 seconds
Subgroup 2	10		
Initial Electrical (RF) Inspection	10	MIL-PRF-55342	VSWR @1.0 GHz and Attenuation @ DC & 1.0 GHz Limits per datasheet and dB Value
Life Test	10	MIL-PRF-55342, MIL-STD-202, Method 108	Test Condition D - Maximum Rated Input Power @ 70°C for 1000 Hours, Electrical measurements made @ 250, 500, 1000 hours
Final Electrical (RF) Inspection	10	MIL-PRF-55342	VSWR @1.0 GHz and Attenuation @ DC & 1.0 GHz Limits per datasheet and dB Value
Group C Inspection			
Load Life	20	MIL-PRF-55342, MIL-STD-202, Method 108	Test Condition D - Maximum Rated Input Power @ 125°C for 1000 Hours, Electrical measurements made @ 0, 250, 500, 1000 hours
Electrical (RF) Inspection	20	MIL-PRF-55342	VSWR @1.0 GHz and Attenuation @ DC & 1.0 GHz Limits per datasheet and dB Value

How To Order



HC05

HC05 ■ ■ ■

1 2 3 4

1 Series name	HC05 Series
2 Attenuation value	01 01 dB through 20 20 dB
3 Test code	A Group A B Group B C Group C
4 Mounting Style	S Planar pretinned W3S Triple wrap pretinned

HCM

HCM ■ ■ ■ ■ ■ S

1 2 3 4 6 6

1 Series name	HCM Series
2 Attenuation value	01 01 dB through 10 10 dB
3 Test code	0A Group A 0B Group B 0C Group C
4 TCA slope	N Negative P Positive
5 TCA (dB/dB/°C)	03 0.003 04 0.004 05 0.005 06 0.006 07 0.007 09 0.009
6 Mounting Style	S Planar pretinned W3S Triple wrap pretinned

TCA* dB/dB/°C	ATTENUATION AT 25°C									
	1 dB	2 dB	3 dB	4 dB	5 dB	6 dB	7 dB	8 dB	9 dB	10 dB
-0.003	-0.03	-0.06	-0.09	-0.12	-0.15	-0.18	-0.21	-0.24	-0.27	-0.30
-0.004	-0.04	-0.08	-0.12	-0.16	-0.20	-0.24	-0.28	-0.32	-0.36	-0.40
-0.005	-0.05	-0.10	-0.15	-0.20	-0.25	-0.30	-0.35	-0.40	-0.45	-0.50
-0.006	-0.06	-0.12	-0.18	-0.24	-0.30	-0.36	-0.42	-0.48	-0.54	-0.60
-0.007	-0.07	-0.14	-0.21	-0.28	-0.35	-0.42	-0.49	-0.56	-0.63	-0.70
-0.009	-0.09	-0.18	-0.27	-0.36	-0.45	-0.54	-0.63	-0.72	-0.81	-0.90

Global Support

UK Headquarters

- London, UK
+44 20 7004 1600
info.uk@smithsinterconnect.com

US Headquarters

- Stuart, FL
+1 772 286 9300
info.us@smithsinterconnect.com

Americas

- Costa Mesa, CA
+1 714 371 1100
info.us@smithsinterconnect.com
- Milpitas, CA
+1 408 957 9607 x 1125
info.us@smithsinterconnect.com
- Stuart, FL
+1 772 286 9300
info.us@smithsinterconnect.com
- Hudson, MA
+1 978 568 0451
info.us@smithsinterconnect.com
- Northampton, MA
+1 413 582 9620
info.northampton@smithsinterconnectinc.com
- Tampa, FL
+ 1 813 901 7200
info.tampa@smithsinterconnectinc.com
- Kansas City, KS
+1 913 342 5544
info.us@smithsinterconnect.com
- Salisbury, MD
+1 800 780 2169
info.us@smithsinterconnect.com
- Thousand Oaks, CA
+1 805 267 0100
info.thousandoaks@smithsinterconnectinc.com

Europe

- Deggendorf, Germany
+49 991 250 120
info.de@smithsinterconnect.com
- Genova, Italy
+39 0 10 60361
info.it@smithsinterconnect.com
- Dundee, UK
+44 1382 427 200
info.dundee@smithsinterconnect.com
- Rouen, France
+33 2 32 96 91 76
info.fr@smithsinterconnect.com
- Elstree, UK
+44 20 8236 2400
info.uk@smithsinterconnect.com

Asia

- Shanghai, China
+86 21 3318 4650
info.asia@smithsinterconnect.com
- Suzhou, China
+86 512 6273 1188
info.asia@smithsinterconnect.com
- Singapore
+65 6846 1655
info.asia@smithsinterconnect.com