

TITLE: SPECIFICATION CONTROL DRAWING

PART IDENTIFIER:

TRP 6-12 X,5



DESCRIPTION: : ROD RESISTOR, BERYLLIA

ASSEMBLY DWG: 1300004

1.0 SPECIFICATIONS:

1.1 ELECTRICAL:

- 1.1.1 RESISTANCE RANGE: 10Ω TO 250Ω.
- 1.1.2 TOLERANCE: 5%.
- 1.1.3 INPUT POWER:
 - 1.1.3.1 IN AIR 125°C: 0.25 WATT.
 - 1.1.3.2 HEAT SINK 100°C: 10 WATTS.

1.2 MECHANICAL:

- 1.2.1 OUTLINE DWG: SEE SHEET 2.
- 1.2.2 WORKMANSHIP: PER MIL-STD-454, REQUIREMENT 9.

1.3 ENVIRONMENTAL:

- 1.3.1 TEMPERATURE RANGE:
 - 1.3.1.1 NON-OPERATING: -55° C TO +150° C.
 - 1.3.1.2 OPERATING: -55°C TO +125°C.

2.0 UNIT MARKING NONE

3.0 QUALITY ASSURANCE:

3.1 SAMPLE INSPECT PER MIL-STD-105, LEVEL II, 1.0 AQL.

- 3.1.1 VISUAL AND MECHANICAL EXAMINATION FOR CONFORMANCE TO CONTROL DRAWING REQUIREMENTS.
- 3.1.2 MEASURE AND RECORD DCR.
 - 3.1.2.1 ACCEPTANCE LIMITS: RESISTANCE VALUES AND TOLERANCE AS SPECIFIED ON SHOP/FACTORY ORDER OR ASSEMBLY.

4.0 PACKAGING: STANDARD PACKING PER 755W002.

EMC TECHNOLOGY 8851 SW OLD KANSAS AVE. STUART, FL 34997	CAGE CODE # 24602		DWG #	1001585000
	CHANGE NOTICE	EN 13-2976	REV LVL	D
			SHEET	1 OF 2

PART ID REF

TRP 6-12

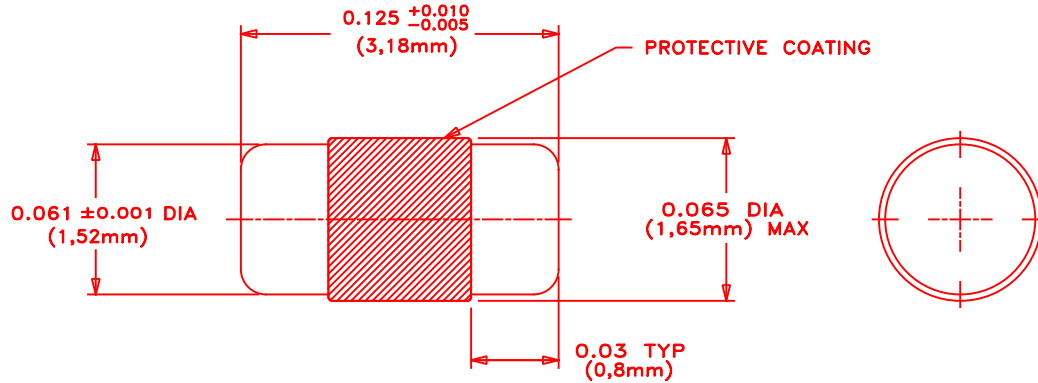

MECHANICAL SPECIFICATIONS:

SUBSTRATE:
MATERIAL - BERYLLIA 99.5%, ASTM F356

TERMINAL:
MATERIAL - GOLD OVER NICKEL PLATING.

**METRIC EQUIVALENTS ARE GIVEN FOR
 REFERENCE INFORMATION ONLY**



8851 SW OLD KANSAS AVE
 STUART, FL 34997
 PHONE NO. (772)286-9300
 FAX NO. (772)283-5286

UNLESS OTHERWISE
 SPECIFIED DIMENSIONS
 ARE IN INCHES

TOLERANCES

FRACT	---
ANG	---
XX	±0.01
XXX	±0.005
XXXX	---

THESE DRAWINGS AND SPECIFICATIONS ARE THE PROPERTY OF EMC TECHNOLOGY INC AND SHALL NOT BE DUPLICATED OR USED AS BASIS FOR THE MANUFACTURE OR SALE OF PARTS OR DEVICES WITHOUT PERMISSION.

CAGE CODE 24602	SCALE 1:1	DRAWN BY CRH 10/23/06	CHECKED BY BEC 4-24-97	APPROVED BY FJV 4-30-97
REV D	CHANGE NOTICE EN 13-2976	DRAWING NO 1001585000	SHEET 2 OF 2	