

Test fleet data gathering for AI training of future Level 5 autonomous vehicle

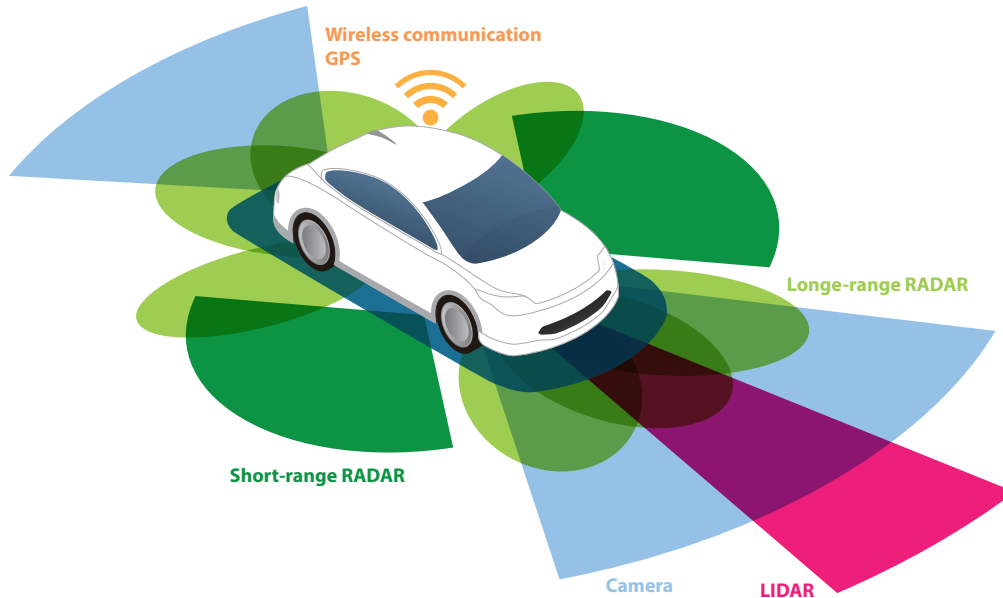

Training a roadworthy algorithm

Neural networks need to be trained on representative datasets that include examples of all possible driving, weather, and situational conditions to ensure reliable, flawless operation of the future self-driving vehicles.

Gathering data

In order to amass as much driving environment data as possible, a typical data-gathering vehicle setup consists of a multitude of sensors including cameras, radar and LIDAR, giving the vehicle 360-degree data gathering capability. In practice this translates into petabytes of training data being shuttled from sensors, to computer, to storage over the vehicle's high-speed, high-bandwidth data collection networks.

Obviously, the exact instrumentation details of specific manufacturers or suppliers are not in the public domain. But one can reasonably assume that the amount of data generated and the speed at which it is generated demand a very robust and high-bandwidth system.

High bandwidth needs call for optical

The data collection network and computing systems of these vehicles are expected to:

- Connect LIDAR and radars.
- Connect high-resolution cameras.
- Provide centralized processing power and storage.
- Operate in harsh environments.

Description of the application

The global automotive industry advances rapidly toward fully autonomous (Level 5) vehicles. Today, many competing data gathering fleets of vehicles are logging millions of km on the roads of the world in order to amass the data required to feed and train the AI that will enable full vehicle autonomy.

The detection accuracy and the size of the dataset demanded by those safety-critical training system is very high, as is the bandwidth, performance, and reliability of the high-speed links providing the data collecting backbone of these vehicles.

The data gathering systems used in those vehicles are expected to operate flawlessly irrespective of weather conditions, visibility, or road surface in order to improve data quality and accuracy.

Eliminating the network bottleneck

Optical technology is the only way to ensure rugged, reliable, high-bandwidth data collection.

By offering much higher speed than what is available with copper interconnects, optic fiber data links remove the bottleneck in the data collection network and enable high-quality uncompressed data to be stored in the vehicle.

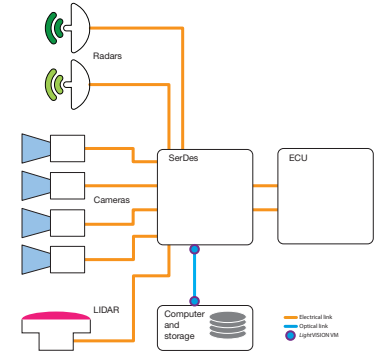
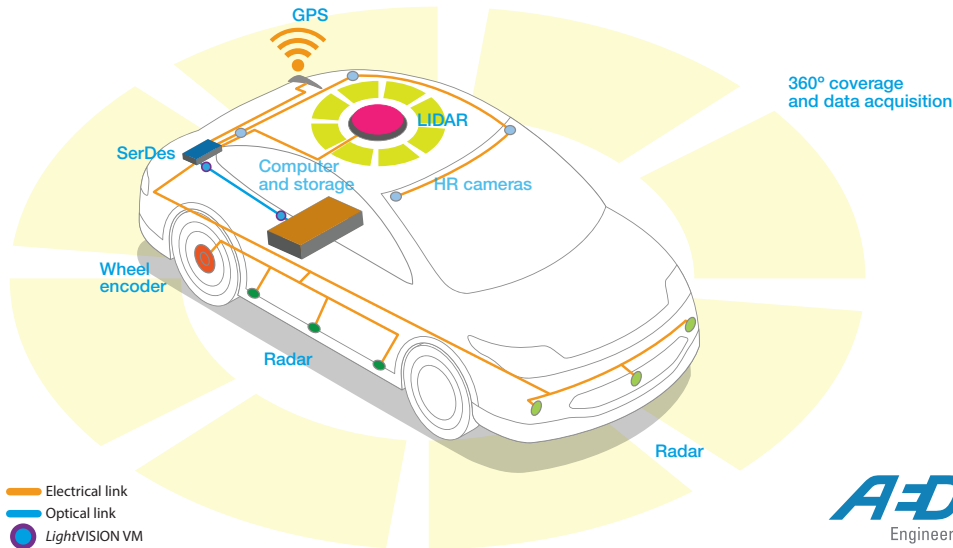

By removing bottlenecks in the data path, the optical link is the ideal backbone of a data gathering system.



Application developed in partnership with AED Engineering.
www.aed-engineering.com

LightVISION 10G VM Series with MPO interface

The *LightVISION*® 10G VM Series is a screw-in, robust, industrial, and RoHS optical module with MPO interface that answers all the requirements of high bandwidth data gathering application. This approach combines a standard MPO cable connection with a robust, board mounted optical engine providing small size (footprint), face-plate or line-card mounting, and convenient optical cabling. In addition, the MPO connector is covered with an outside cover boot addressing the issue of water and dust contamination.

The *LightVISION* 10G VM Series acts like a QSFP+ but offers reduced dimensions and power consumption, industrial temperature range, multiple board mounting options, and board-mount and edge-mount capability.

This optical module offers advantages over the QSFP+ form-factor and is backed by the Reflex Photonics proven reliability and rugged designs.

Benefits of using the *LightVISION* 10G VM Series industrial transceiver

- Robust screw-in board-mounted optical module with reduced footprint suitable for harsh environment
- Bandwidth from 20G (2 TX or 2 RX channel) to 120G (12 TX or 12 RX channel)
- Performance of up to 10.3125 Gbps/channel
- Lightweight and easy to integrate optical cable
- Standard MPO parallel fiber connector
- Multimode 850 nm wavelength laser
- Flexible height adjustable with LGA interposer
- Rugged RoHS electrical interface
- Low power consumption: <100 mW per channel

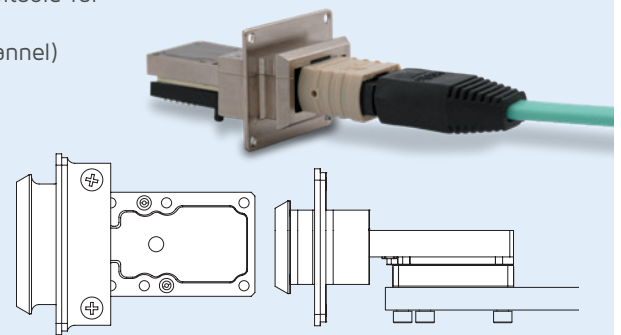

Real size for *LightVISION* 10G VM Series with MPO interface.

more > smithsinterconnect.com | [in](#) [t](#) [v](#)