

TITLE: SPECIFICATION CONTROL DRAWING

PART IDENTIFIER:

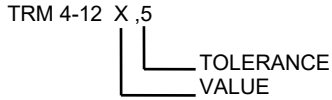

DESCRIPTION: ROD RESISTOR, ALUMINA

ASSEMBLY DWG: 1200004

1.0 SPECIFICATIONS:

1.1 ELECTRICAL:

- 1.1.1 RESISTANCE RANGE: 10Ω TO 250Ω.
- 1.1.2 TOLERANCE: 5%.
- 1.1.3 INPUT POWER:
 - 1.1.3.1 IN AIR 125° C: 0.1 WATT.
 - 1.1.3.2 HEAT SINK 100°C: 1 WATT.

1.2 MECHANICAL:

- 1.2.1 OUTLINE DWG: SEE SHEET 2.
- 1.2.2 WORKMANSHIP: PER MIL-STD-454, REQUIREMENT 9.

1.3 ENVIRONMENTAL:

- 1.3.1 TEMPERATURE RANGE:
 - 1.3.1.1 NON-OPERATING: -55° C TO +150° C.
 - 1.3.1.2 OPERATING: -55°C TO +125°C.

2.0 UNIT MARKING: NONE

3.0 QUALITY ASSURANCE:

2.1 SAMPLE INSPECT PER MIL-STD-105, LEVEL II, 1.0 AQL.

- 2.1.1 VISUAL AND MECHANICAL EXAMINATION FOR CONFORMANCE TO CONTROL DRAWING REQUIREMENTS.
- 2.1.2 MEASURE AND RECORD DCR.
 - 2.1.2.1 ACCEPTANCE LIMITS: RESISTANCE VALUES AND TOLERANCE AS SPECIFIED ON SHOP/FACTORY ORDER OR ASSEMBLY.

4.0 PACKAGING: STANDARD PACKING PER 755W002.

EMC TECHNOLOGY 8851 SW OLD KANSAS AVE. STUART, FL 34997	CAGE CODE # 24602		DWG #	1001475000
	CHANGE NOTICE	EN 14-0636	REV LVL	D
			SHEET	1 OF 2

PART ID REF

TRM 4-12

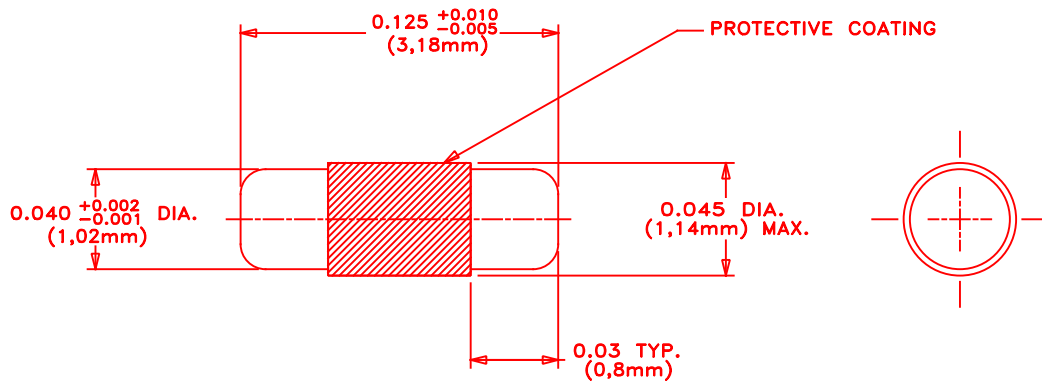

MECHANICAL SPECIFICATIONS:

SUBSTRATE:
MATERIAL - ALUMINA 96%, MIL-I-10.

TERMINAL:
MATERIAL - GOLD OVER COPPER OVER NICKEL PLATING.

**METRIC EQUIVALENTS GIVEN IN [mm]
FOR REFERENCE INFORMATION ONLY**



8851 SW OLD KANSAS AVE
STUART, FL 34997
PHONE NO. (772)286-9300
FAX NO. (772)283-5286

UNLESS OTHERWISE
SPECIFIED DIMENSIONS
ARE IN INCHES

TOLERANCES

FRACT	---
ANG	---
XX	±0.01
XXX	±0.005
XXXX	---

THESE DRAWINGS AND SPECIFICATIONS ARE THE PROPERTY OF EMC TECHNOLOGY INC AND SHALL NOT BE DUPLICATED OR USED AS BASIS FOR THE MANUFACTURE OR SALE OF PARTS OR DEVICES WITHOUT PERMISSION.

CAGE CODE	SCALE	DRAWN BY	CHECKED BY	APPROVED BY
24602	1:1	JG 3/11/09		
REV	CHANGE NOTICE	DRAWING NO	SHEET	
D	EN 14-0636	1001475000	2 OF 2	