

TS05 Series

ATTENUATOR CHIP DC-18 GHZ

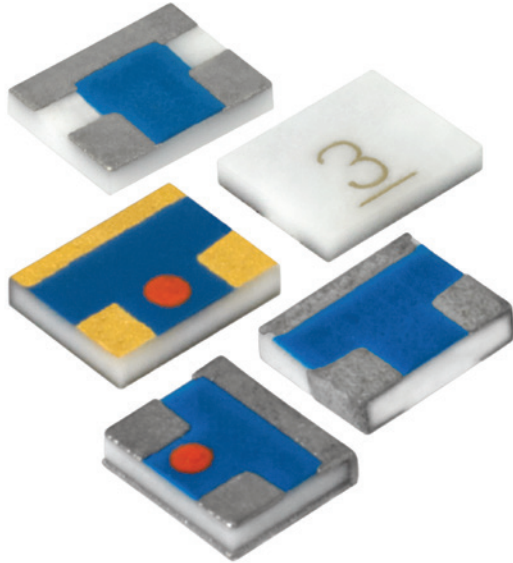

Smiths Interconnect is the world leader in chip attenuators offering the widest selection of products from DC through Q band. Chip components are offered on Alumina, Aluminum Nitride, Beryllium Oxide, and CVD Diamond for a wide range of applications. Backed by proven performance and significant heritage, Smiths Interconnect is the leader in high reliability components.

The TS05 platform offers significant heritage and proven performance in a cost effective commercial grade product. High reliability tested options are also available to ensure mission success in demanding high reliability applications. Rated for DC-18 GHz with excellent broadband response, the TS05 series of products has a wide range of applications. It is constructed on an Alumina substrate with rugged thick film terminations and passivated Tantalum Nitride resistive elements. The product also includes a protective coating for added protection from various environmental conditions. Multiple attenuation values and mounting configuration are available to support both surface mount and wire bond applications. Various finish options are also available including RoHS compliance.

TS05 Series Chip Attenuators offer proven performance and significant high reliability heritage in a commercial grade product.

Features and Benefits

- Small Footprint
- Multiple Mounting Configurations
- Broad Frequency Range
- Low VSWR
- Wide Range of Attenuation Values
- Tight Attenuation Tolerance
- High Reliability Options Available

Applications

- Amplifier Circuits
- Transmit/Receive Modules
- Up/Down Converters
- Instrumentation
- Radar
- Broadcast

Technical Characteristics

Mounting Configuration Options	Planar	Single Wrap (W1)	Triple Wrap (W3)	Wire Bondable Gold (WB1)
--------------------------------	--------	------------------	------------------	--------------------------

Electrical

Nominal Impedance	50 ohms									
Frequency Range	DC -12.4 GHz (*18 GHz for planar option)									
Attenuation Values Available	0-20 in 1 dB Increments									
Attenuation Accuracy	ATTENUATION ACCURACY									
	Attenuation Value (dB)	DC-4 GHz		4-8 GHz		8-12.4 GHz		12.4-18 GHz*		
	0	-0, +0.3		-0, +0.5		-0, +0.5		-0, +0.5		
	1-3	± 0.3		± 0.5		± 0.5		± 0.5		
	4-6	± 0.4		± 0.5		± 0.5		± 0.75		
	7-10	± 0.5		± 0.5		± 0.75		± 1.0		
	11-15	± 0.75		-3.0, +0.5		-3.5, +0.5		-		
16-20	± 1.0		-4.0, +0.5		-6.0, +1.0		-			
Power Rating	POWER RATING									
	dB Values		Watts		dB Values		Watts			
	0-1		5.00		2-3		2.00			
Peak Power	1 Watt based on 10 μS pulse width @ 1% Duty Cycle									
	1 Watt based on 10 μS pulse width @ 1% Duty Cycle									
VSWR	VSWR									
			DC-4 GHz		4-8 GHz		8-12.4 GHz		12.4-18 GHz*	
			1.25:1 Max		1.35:1 Max		1.50:1 Max		1.50:1 Max	

Environmental

Operating Temperature	-55°C to +150°C
Storage Temperature	-65°C to +150°C
Moisture Sensitivity Level	MSL 1 - Unlimited

Mechanical

Substrate Material	Alumina (Al ₂ O ₃) 96%		
Resistive Film	Thin Film, Tantalum Nitride		
Terminal Material	Thick Film		Thick Film Bondable Gold Input/Output Pads, Solderable Platinum Silver Ground
Protective Coating	Polymer		
Finish Options	Blank	Solder Plated (Sn60/Pb40)	
	-F	Silver Plated (RoHS Compliant)	
	-S	Pretinned (Sn60/Pb40)	
	-G	Gold (Thick Film) *Available Planar Only	

Marking

Unit Marking	dB Value	Colored Dot Marking	dB Value	Colored Dot Marking
--------------	----------	---------------------	----------	---------------------

Quality Assurance

	Sample visual and mechanical inspection - 1.0 AQL per mechanical drawing requirements. Periodic electrical inspection performed for commercial grade products. High reliability tested products are available per MIL-PRF-55342.
--	--

Packaging

Standard Packaging	Tape and Reel or Waffle Pack
--------------------	------------------------------

Power Derating Curve

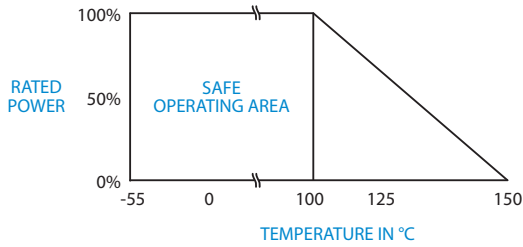

Typical Data

TS05XX Series Attenuation

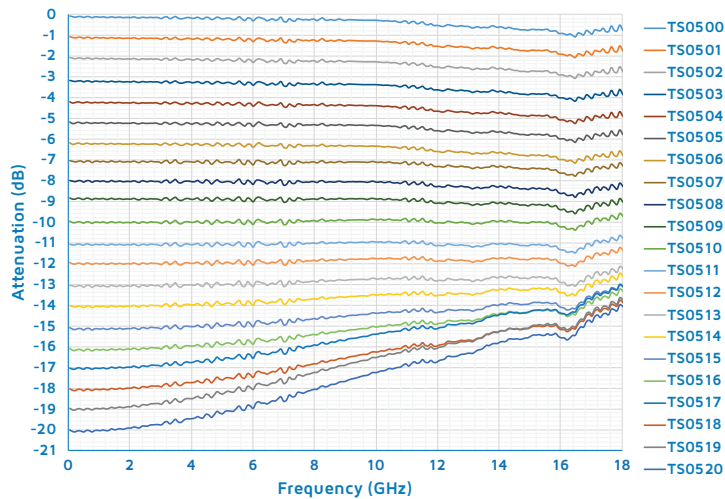

TS05XX Series VSWR

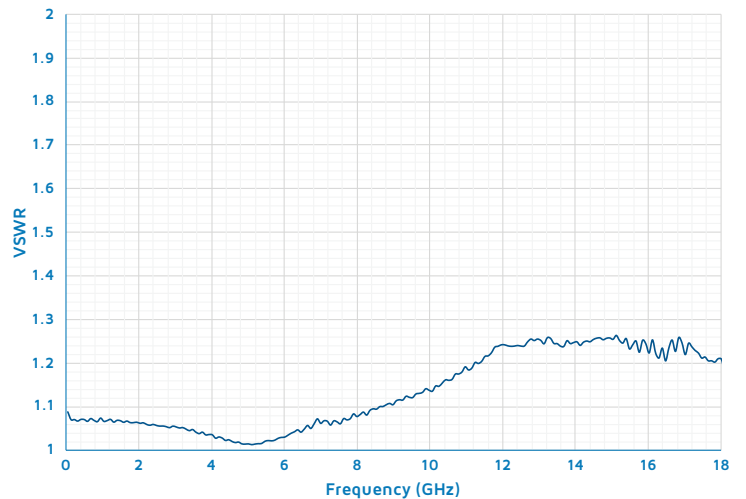

Dot Marking Reference

dB Value	DOT Color		dB Value	DOT Color	
	1st Dot	2nd Dot		1st Dot	2nd Dot
0	Black	-	11	Brown	Brown
1	Brown	-	12	Brown	Red
2	Red	-	13	Brown	Orange
3	Orange	-	14	Brown	Yellow
4	Yellow	-	15	Brown	Green
5	Green	-	16	Brown	Blue
6	Blue	-	17	Brown	Violet
7	Violet	-	18	Brown	Gray
8	Gray	-	19	Brown	White
9	White	-	20	Red	Black
10	Brown	Black			

Mechanical

TS05XX - Planar Option

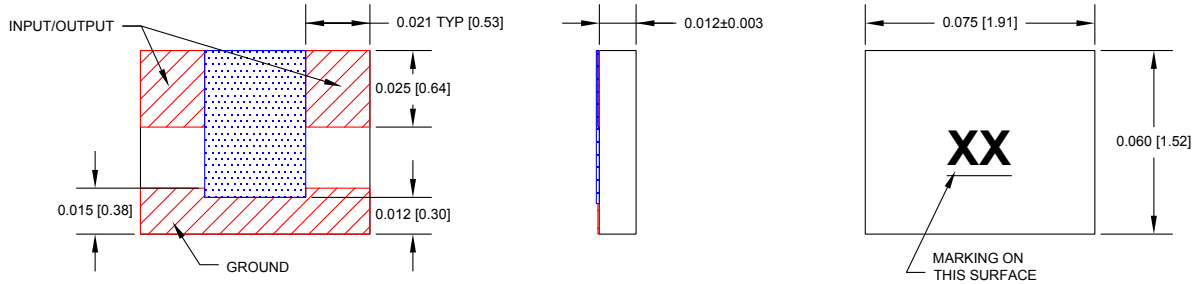

TS05XXW1 - Single Wrap Option

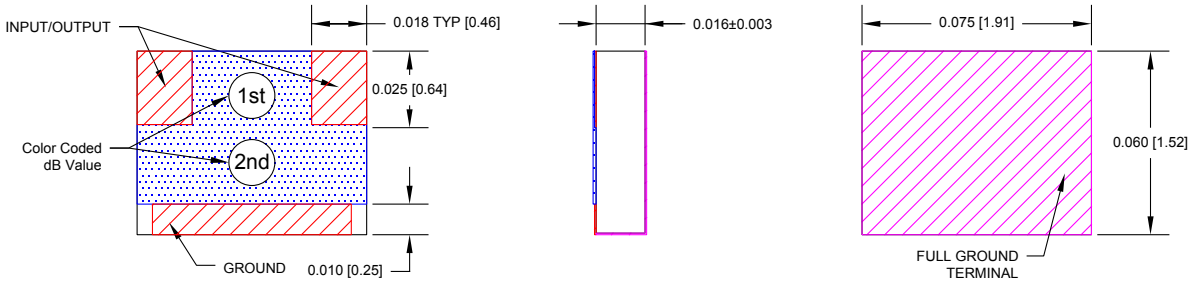

TS05XXW3 - Triple Wrap Option

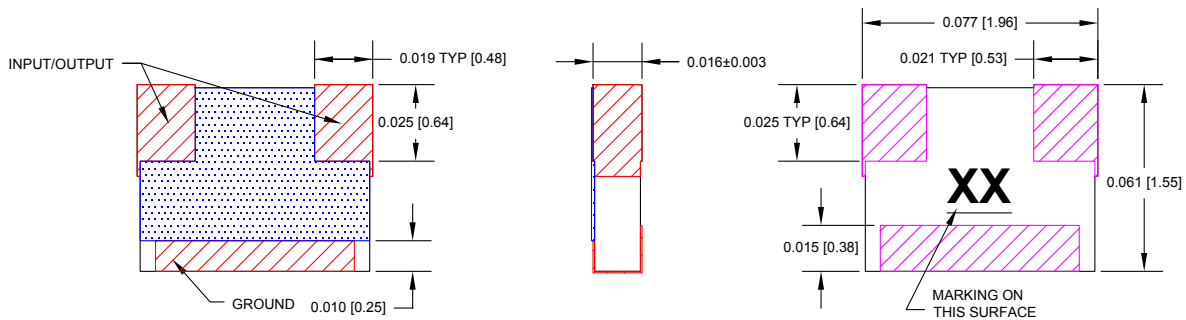

TS05XXWB1 - Wire Bondable Option

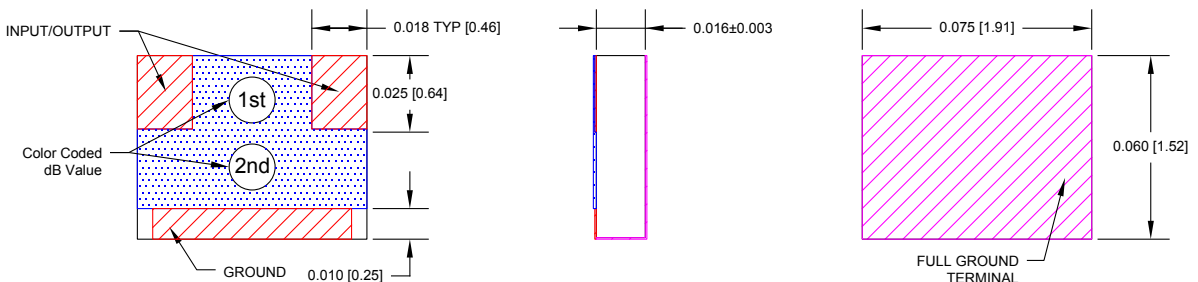

*Dimensions apply before solder, allow 0.015" max for all pretinned surfaces
Unless otherwise specified, tolerance: X.XXX = ±0.005"

Suggested Mounting Footprint

Part Number	Inches						MM					
	A	B	C	D	S	W	A	B	C	D	S	W
TS05XX (Planar)	0.025	0.027	0.03	0.015	0.019	0.08	0.64	0.69	0.76	0.38	0.48	2.032
TS05XXW3 (Triple Wrap)	0.022	0.028	0.041	0.013	0.026	0.075	0.56	0.71	1.04	0.33	0.66	1.91

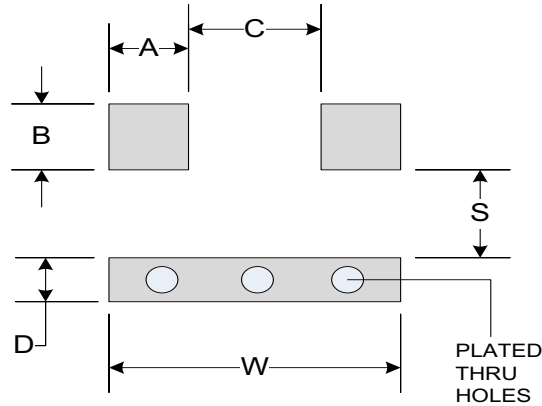

How To Order

Specify Model Number: **TS05XXXXXX**

TS05	00	W1	00
1	2	3	4
1 Series Name	TS05 Series		
2 Attenuation Value	00 00 dB through 20 20 dB		
3 Options	<input type="checkbox"/> Planar W1 Single Wrap Ground <input checked="" type="checkbox"/> W3 Triple Wrap - All Ports WB1 Wire Bondable		
4 Terminal Finish	<input checked="" type="checkbox"/> Standard S Pretinning F RoHS G Gold		

Global Support

UK Headquarters

- London, UK
+44 20 7004 1600
info.uk@smithsinterconnect.com

US Headquarters

- Stuart, FL
+1 772 286 9300
info.us@smithsinterconnect.com

Americas

- Costa Mesa, CA
+1 714 371 1100
info.us@smithsinterconnect.com
- Milpitas, CA
+1 408 957 9607 x-1125
info.us@smithsinterconnect.com
- Stuart, FL
+1 772 286 9300
info.us@smithsinterconnect.com
- Hudson, MA
+1 978 568 0451
info.us@smithsinterconnect.com
- Northampton, MA
+1 413 582 9620
info.northampton@smithsinterconnectinc.com
- Tampa, FL
+ 1 813 901 7200
info.tampa@smithsinterconnectinc.com
- Kansas City, KS
+1 913 342 5544
info.us@smithsinterconnect.com
- Salisbury, MD
+1 800 780 2169
info.us@smithsinterconnect.com
- Thousand Oaks, CA
+1 805 267 0100
info.thousandoaks@smithsinterconnectinc.com

Europe

- Deggendorf, Germany
+49 991 250 120
info.de@smithsinterconnect.com
- Genova, Italy
+39 0 10 60361
info.it@smithsinterconnect.com
- Dundee, UK
+44 1382 427 200
info.dundee@smithsinterconnect.com
- Rouen, France
+33 2 32 96 91 76
info.fr@smithsinterconnect.com
- Elstree, UK
+44 20 8236 2400
info.uk@smithsinterconnect.com

Asia

- Shanghai, China
+86 21 3318 4650
info.asia@smithsinterconnect.com
- Suzhou, China
+86 512 6273 1188
info.asia@smithsinterconnect.com
- Singapore
+65 6846 1655
info.asia@smithsinterconnect.com

more > smithsinterconnect.com | [in](#) [twitter](#) [G+](#) [YouTube](#)