

KM Series

High Density PCB Connectors

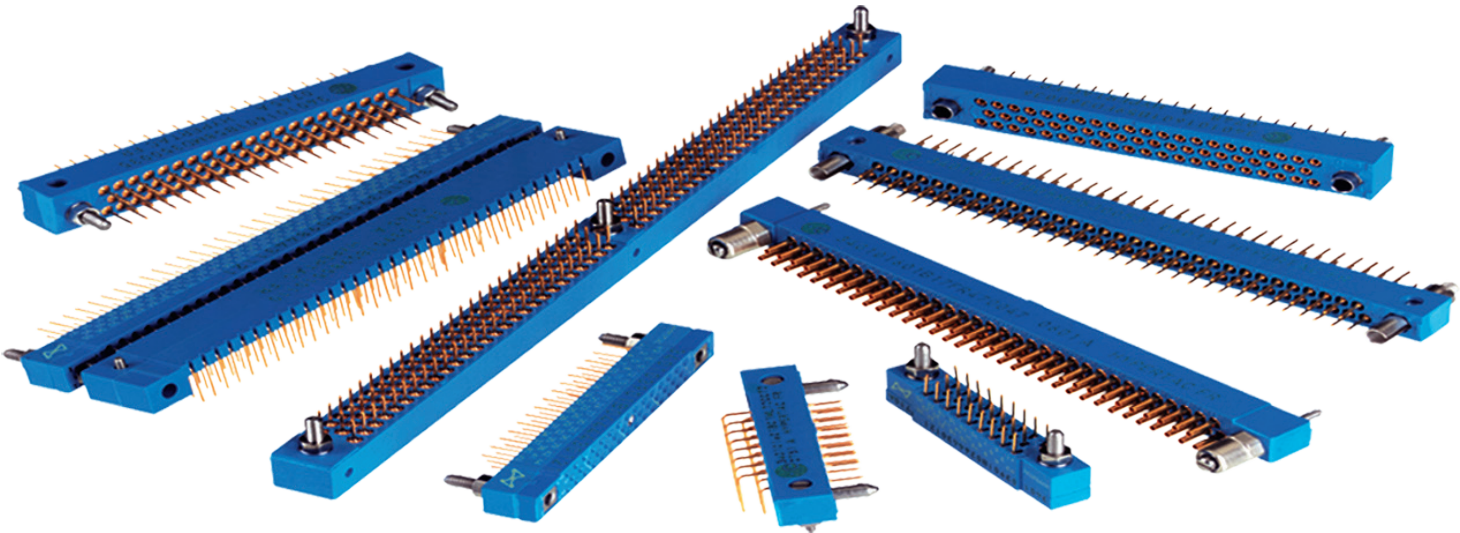

Hypertac[®] Hyperboloid Technology

Smiths Interconnect offers an extensive range of superior contact technologies suitable for standard and custom solutions. Hypertac[®] (HYPERboloid conTACT) is the original superior performing hyperboloid contact technology designed for use in all applications and in harsh and demanding environments where high reliability and safety are critical. The inherent electrical and mechanical characteristics of the Hypertac hyperboloid contact ensures unrivalled performance in terms of reliability, number of mating cycles, low contact force and minimal contact resistance. The shape of the contact sleeve is formed by hyperbolically arranged contact wires, which align themselves elastically as contact lines around the pin, providing a number of linear contact paths.

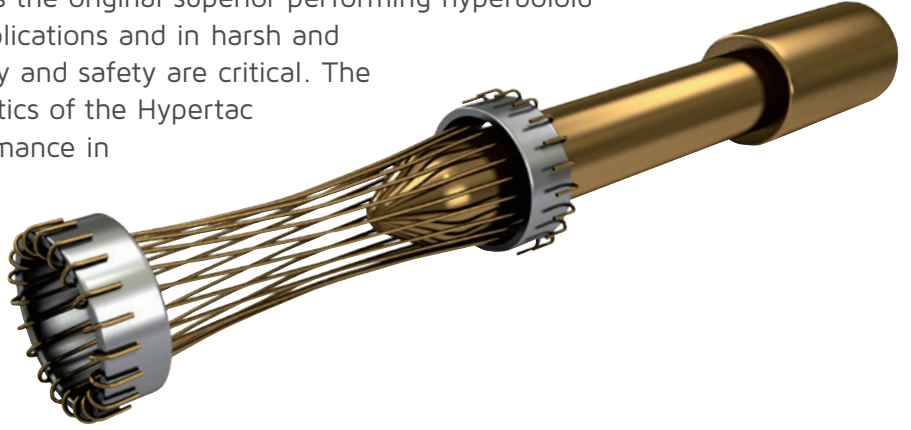

Features

Low insertion/extraction forces

The angle of the socket wires allows tight control of the pin insertion and extraction forces. The spring wires are smoothly deflected to make line contact with the pin.

Long contact life

The smooth and light wiping action minimizes wear on the contact surfaces. Contacts perform up to 100,000 insertion/extraction cycles with minimal degradation in performance.

Lower contact resistance

The design provides a far greater contact area and the wiping action of the wires insures a clean and polished contact surface. Our contact technology has about half the resistance of conventional contact designs.

Higher current ratings

The design parameters of the contact (e.g., the number, diameter and angle of the wires) may be modified for any requirement. The number of wires can be increased so the contact area is distributed over a larger surface. Thus, the high current carried by each wire because of its intimate line contact, can be multiplied many times.

Immunity to shock & vibration

The low mass and resultant low inertia of the wires enable them to follow the most abrupt or extreme excursions of the pin without loss of contact. The contact area extends 360° around the pin and is uniform over its entire length. The 3 dimensional symmetry of the Hypertac contact design guarantees electrical continuity in all circumstances.

Benefits

High density interconnect systems

Significant reductions in size and weight of sub-system designs. No additional hardware is required to overcome mating and unmating forces.

Low cost of ownership

The Hypertac contact technology will surpass most product requirements, thus eliminating the burden and cost of having to replace the connector or the entire subsystem.

Low power consumption

The lower contact resistance of our technology results in a lower voltage drop across the connector reducing the power consumption and heat generation within the system.

Maximum contact performance

The lower contact resistance of the Hypertac contact reduces heat build-up; therefore Hypertac contacts are able to handle far greater current in smaller contact assemblies without the detrimental effects of high temperature.

Reliability under harsh environments

Harsh environmental conditions require connectors that will sustain their electrical integrity even under the most demanding conditions such as shock and vibration. The Hypertac contact provides unmatched stability in demanding environments when failure is not an option.

Technical Characteristics

Contact diameter	HYPERTAC® type Ø 0.50 mm
Number of contact	Up to 162
Pitch	1.905 mm between rows - 1.27 mm between quicuncial contacts
Rows	3

Materials & Platings

Contact	Brass or bronze	
Molding	Glass fiber filled diallyl - Phtalate	
Guides	Stainless steel or nickel plated brass	
	Standard	ESA
Pin body	0.25 µm gold / 1.27 µm Ni	1.27 µm gold / 1.27 µm Ni (min.)
Socket body	0.25 µm gold / 1.27 µm Ni on active area 1.27 µm Ni on non active area	0.25 µm gold / 1.27 µm Ni (min.)
Socket wires	1 µm gold / 0.20 µm Ni	1.27 µm gold / 0.20 µm Ni (min.)

Electrical

Current rating (at 25°C)	3 A max.
Dielectric withstanding voltage	800 Vrms
Contact resistance	≤8 mΩ
Insulation resistance	>104 MΩ (500 Vcc)

Mechanical

Mating & unmating cycle	5000
Guiding	By two outside guides (2 guiding styles) and one central guide (3 guiding styles)
Keying	By rotating of outside polarized guides (up to 16 keying)

Environmental

Temperature range	-55° C to 125° C
Conformity	ESA/ESCC3401/016 - 3401/017, NF C-UTE C 93-424

How To Order



Hypertac & ESA Correspondence Table

ESA 3401/039 01B



1 Series																																			
2 Number of contacts	0 2 6 0 4 4 0 6 2 0 8 0 0 9 8 1 4 4 1 6 2																																		
3 Molding polarity	<table border="1"> <thead> <tr> <th colspan="2">NF C-UTE C 93-424 ESA/ESCC 3401/03901B SPACE GRADE</th> <th colspan="2">NF C-UTE C 93-424 ESA/ESCC 3401/03901B SPACE GRADE</th> <th colspan="2">NF C-UTE C 93-424 ESA/ESCC 3401/03901B SPACE GRADE</th> </tr> </thead> <tbody> <tr> <td>12 - 54</td> <td>Female plug</td> <td>1A - -</td> <td>Tinned female plug**</td> <td>26 - 46</td> <td>Tinned female receptacle*</td> </tr> <tr> <td>13 55 55</td> <td>Male plug</td> <td>1B - -</td> <td>Tinned male plug**</td> <td>27 - 47</td> <td>Tinned male receptacle*</td> </tr> <tr> <td>16 - 56</td> <td>Tinned female plug*</td> <td>22 44 44</td> <td>Female receptacle</td> <td>2A - -</td> <td>Tinned female receptacle**</td> </tr> <tr> <td>17 - 57</td> <td>Tinned male plug*</td> <td>23 - 45</td> <td>Male receptacle</td> <td>2B - -</td> <td>Tinned male receptacle**</td> </tr> </tbody> </table>	NF C-UTE C 93-424 ESA/ESCC 3401/03901B SPACE GRADE		NF C-UTE C 93-424 ESA/ESCC 3401/03901B SPACE GRADE		NF C-UTE C 93-424 ESA/ESCC 3401/03901B SPACE GRADE		12 - 54	Female plug	1A - -	Tinned female plug**	26 - 46	Tinned female receptacle*	13 55 55	Male plug	1B - -	Tinned male plug**	27 - 47	Tinned male receptacle*	16 - 56	Tinned female plug*	22 44 44	Female receptacle	2A - -	Tinned female receptacle**	17 - 57	Tinned male plug*	23 - 45	Male receptacle	2B - -	Tinned male receptacle**				
NF C-UTE C 93-424 ESA/ESCC 3401/03901B SPACE GRADE		NF C-UTE C 93-424 ESA/ESCC 3401/03901B SPACE GRADE		NF C-UTE C 93-424 ESA/ESCC 3401/03901B SPACE GRADE																															
12 - 54	Female plug	1A - -	Tinned female plug**	26 - 46	Tinned female receptacle*																														
13 55 55	Male plug	1B - -	Tinned male plug**	27 - 47	Tinned male receptacle*																														
16 - 56	Tinned female plug*	22 44 44	Female receptacle	2A - -	Tinned female receptacle**																														
17 - 57	Tinned male plug*	23 - 45	Male receptacle	2B - -	Tinned male receptacle**																														
4 Termination styles	<table border="1"> <tbody> <tr> <td>10 90° length 3 mm ("A" molding)</td> <td>30 Through board solder - straight - length 4.5 mm</td> <td>51 Wire wrap (3 wrapping levels)</td> </tr> <tr> <td>10 90° length 3 mm ("B" molding)</td> <td>31 Through board solder - straight - length 5.6 mm</td> <td>90 Male - Female</td> </tr> <tr> <td>11 90° length 4 mm ("A" molding)</td> <td>40 Solder bucket</td> <td>91 Female - male</td> </tr> <tr> <td>13 90° length 5.5 mm ("B" molding)</td> <td>50 Wire wrap (2 wrapping levels)</td> <td></td> </tr> </tbody> </table>	10 90° length 3 mm ("A" molding)	30 Through board solder - straight - length 4.5 mm	51 Wire wrap (3 wrapping levels)	10 90° length 3 mm ("B" molding)	31 Through board solder - straight - length 5.6 mm	90 Male - Female	11 90° length 4 mm ("A" molding)	40 Solder bucket	91 Female - male	13 90° length 5.5 mm ("B" molding)	50 Wire wrap (2 wrapping levels)																							
10 90° length 3 mm ("A" molding)	30 Through board solder - straight - length 4.5 mm	51 Wire wrap (3 wrapping levels)																																	
10 90° length 3 mm ("B" molding)	31 Through board solder - straight - length 5.6 mm	90 Male - Female																																	
11 90° length 4 mm ("A" molding)	40 Solder bucket	91 Female - male																																	
13 90° length 5.5 mm ("B" molding)	50 Wire wrap (2 wrapping levels)																																		
5 Mounting hardware	<p>Guide Styles (consult us for special guides)</p> <table border="1"> <tbody> <tr> <td>110 Male polarized, transverse mount⁽¹⁾</td> <td>127 Male unpolarized, vertical mount⁽²⁾</td> <td>156 Male unpolarized, transverse mount⁽²⁾</td> </tr> <tr> <td>111 Male polarized, vertical mount⁽²⁾</td> <td>128 Male unpolarized, float mount⁽²⁾</td> <td>173 Female unpolarized, transverse mount⁽¹⁾</td> </tr> <tr> <td>112 Male polarized, vertical mount⁽²⁾</td> <td>130 Female unpolarized, vertical mount⁽²⁾</td> <td>174 Female polarized, transverse mount⁽¹⁾</td> </tr> <tr> <td>113 Male polarized, float mount⁽²⁾</td> <td>133 Female unpolarized, transverse mount⁽²⁾</td> <td>190 Female power or mass contact, vertical mount⁽²⁾</td> </tr> <tr> <td>121 Female polarized, vertical mount⁽²⁾</td> <td>143 Female polarized, vertical mount⁽²⁾</td> <td>191 Male power or mass contact, transverse mount⁽¹⁾</td> </tr> <tr> <td>123 Female polarized, float mount⁽²⁾</td> <td>153 Female unpolarized, transverse mount⁽²⁾</td> <td>703 Female - male unpolarized guide ⁽¹⁾</td> </tr> <tr> <td>124 Female polarized, transverse mount⁽²⁾</td> <td>154 Female polarized, transverse mount⁽²⁾</td> <td></td> </tr> <tr> <td>125 Male unpolarized, transverse mount⁽¹⁾</td> <td>155 Male unpolarized, transverse mount⁽²⁾</td> <td></td> </tr> </tbody> </table> <p>Locking Styles</p> <table border="1"> <thead> <tr> <th>FEMALE</th> <th>MALE</th> </tr> </thead> <tbody> <tr> <td>202 Jackscrew, vertical mount⁽²⁾</td> <td>201 Jackscrew, free connector⁽²⁾</td> </tr> <tr> <td>203 Jackscrew, transverse mount</td> <td>205 Jackscrew, transverse mount⁽¹⁾</td> </tr> <tr> <td>204 Jackscrew, transverse mount⁽²⁾</td> <td>206 Jackscrew, free connector⁽²⁾</td> </tr> <tr> <td>207 Jackscrew, vertical mount⁽²⁾</td> <td></td> </tr> </tbody> </table>	110 Male polarized, transverse mount ⁽¹⁾	127 Male unpolarized, vertical mount ⁽²⁾	156 Male unpolarized, transverse mount ⁽²⁾	111 Male polarized, vertical mount ⁽²⁾	128 Male unpolarized, float mount ⁽²⁾	173 Female unpolarized, transverse mount ⁽¹⁾	112 Male polarized, vertical mount ⁽²⁾	130 Female unpolarized, vertical mount ⁽²⁾	174 Female polarized, transverse mount ⁽¹⁾	113 Male polarized, float mount ⁽²⁾	133 Female unpolarized, transverse mount ⁽²⁾	190 Female power or mass contact, vertical mount ⁽²⁾	121 Female polarized, vertical mount ⁽²⁾	143 Female polarized, vertical mount ⁽²⁾	191 Male power or mass contact, transverse mount ⁽¹⁾	123 Female polarized, float mount ⁽²⁾	153 Female unpolarized, transverse mount ⁽²⁾	703 Female - male unpolarized guide ⁽¹⁾	124 Female polarized, transverse mount ⁽²⁾	154 Female polarized, transverse mount ⁽²⁾		125 Male unpolarized, transverse mount ⁽¹⁾	155 Male unpolarized, transverse mount ⁽²⁾		FEMALE	MALE	202 Jackscrew, vertical mount ⁽²⁾	201 Jackscrew, free connector ⁽²⁾	203 Jackscrew, transverse mount	205 Jackscrew, transverse mount ⁽¹⁾	204 Jackscrew, transverse mount ⁽²⁾	206 Jackscrew, free connector ⁽²⁾	207 Jackscrew, vertical mount ⁽²⁾	
110 Male polarized, transverse mount ⁽¹⁾	127 Male unpolarized, vertical mount ⁽²⁾	156 Male unpolarized, transverse mount ⁽²⁾																																	
111 Male polarized, vertical mount ⁽²⁾	128 Male unpolarized, float mount ⁽²⁾	173 Female unpolarized, transverse mount ⁽¹⁾																																	
112 Male polarized, vertical mount ⁽²⁾	130 Female unpolarized, vertical mount ⁽²⁾	174 Female polarized, transverse mount ⁽¹⁾																																	
113 Male polarized, float mount ⁽²⁾	133 Female unpolarized, transverse mount ⁽²⁾	190 Female power or mass contact, vertical mount ⁽²⁾																																	
121 Female polarized, vertical mount ⁽²⁾	143 Female polarized, vertical mount ⁽²⁾	191 Male power or mass contact, transverse mount ⁽¹⁾																																	
123 Female polarized, float mount ⁽²⁾	153 Female unpolarized, transverse mount ⁽²⁾	703 Female - male unpolarized guide ⁽¹⁾																																	
124 Female polarized, transverse mount ⁽²⁾	154 Female polarized, transverse mount ⁽²⁾																																		
125 Male unpolarized, transverse mount ⁽¹⁾	155 Male unpolarized, transverse mount ⁽²⁾																																		
FEMALE	MALE																																		
202 Jackscrew, vertical mount ⁽²⁾	201 Jackscrew, free connector ⁽²⁾																																		
203 Jackscrew, transverse mount	205 Jackscrew, transverse mount ⁽¹⁾																																		
204 Jackscrew, transverse mount ⁽²⁾	206 Jackscrew, free connector ⁽²⁾																																		
207 Jackscrew, vertical mount ⁽²⁾																																			

(1) Molding A - (2) Molding B

- * For 90° & straight terminations (splicing on PCB) -
- ** RoHS compliant for 90° & straight terminations (splicing on PCB)

Molding Styles

Plug

One Part (molding A)

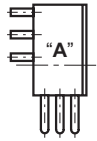

- Fitted with male contacts**
- 90° through board solder

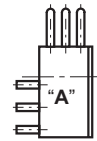

- Fitted with male contacts**
- 90° through board solder
(same design as the "A" plug type but printed as receptacle)

Two Parts (molding B)

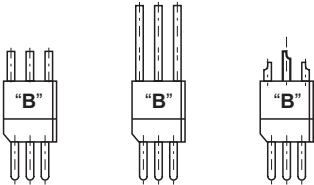

- Fitted with male contacts (pins)**
- Straight through board solder
 - Wire wrap type
(2 and 3 wrapping levels)
 - Solder bucket

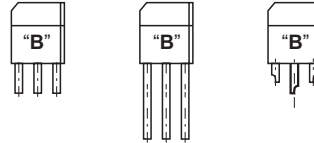

- Fitted with female contacts**
- Straight through board solder
 - Wire wrap type
(2 and 3 wrapping levels)
 - Solder bucket
(same design as the "B" plug type but printed as receptacle)

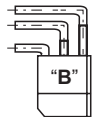

- Fitted with female contacts (sockets)**
- 90° through board solder
Note: the spacing of the rows for board preparation is different to the spacing of the plug fitted with the 90° termination

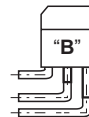

- Fitted with female contacts (sockets)**
- 90° through board solder
Note: the spacing of the rows for board preparation is different to the spacing of the plug fitted with the 90° termination

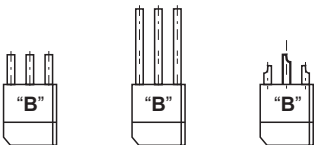

- Straight through board solder
- Wire wrap type
(2 and 3 wrapping levels)
- Solder bucket

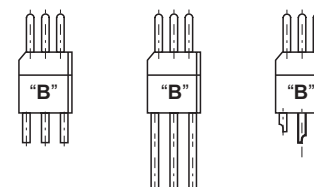

- Fitted with male contacts (pins)**
- Straight through board solder
 - Wire wrap type
(2 and 3 wrapping levels)
 - Solder bucket
(same design as the "B" plug type but printed as receptacle)

Contact Terminations

Plug

Receptacle

Male

Female

Female

Male

90° Through board solder

Ref: 10 Ref : 10 (only A Molding)

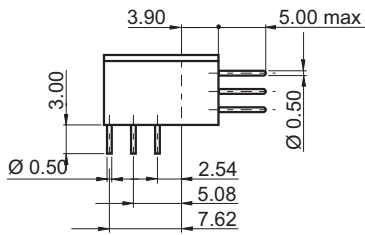

Moulding "A"

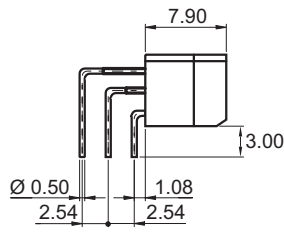

Moulding "B"

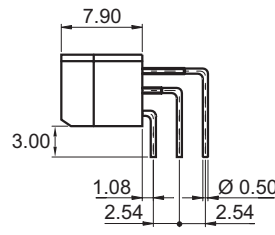

Moulding "B"

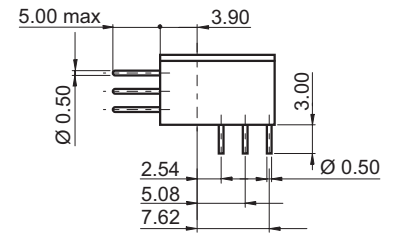

Moulding "A"

90° through board solder

Moulding A Ref: 11 (X=4.00) Moulding B Ref: 13 (X=5.50)

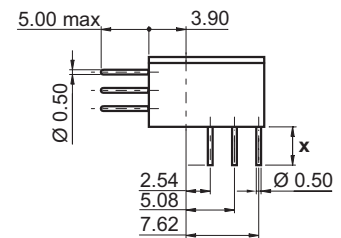
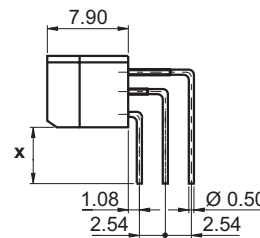
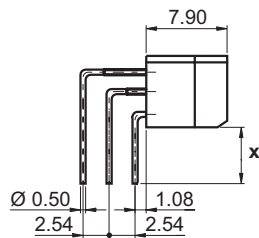
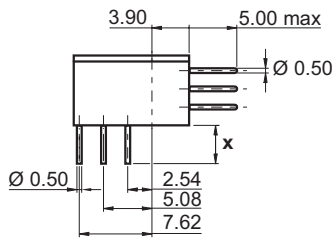

Straight through board solder

Ref: 30 (X=4.50) Ref : 30 Ref: 31 (X=5.60) Ref : 31

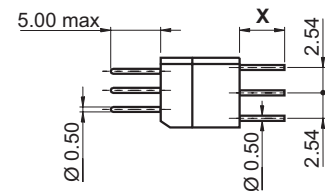
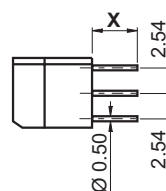
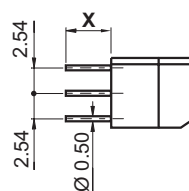
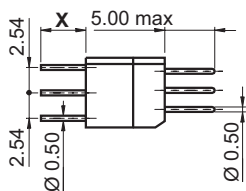

Solder bucket (AWG 26 max)

Ref: 40 Ref : 40

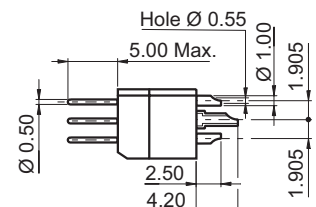
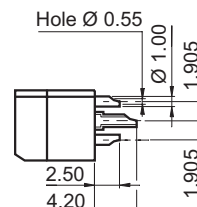
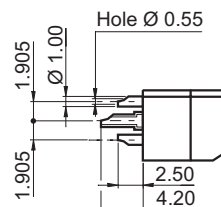
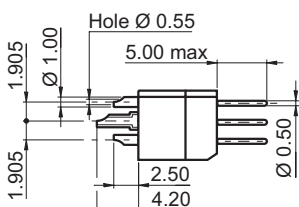

Note: moulding A and B need different preparation board details for 90° tail termination.

Contact Terminations

Plug

Male

Female

Receptacle

Female

Male

Wire wrap (2 wrapping levels)

Ref: **50** Ref:  **50**

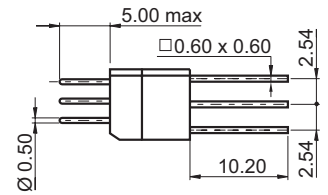
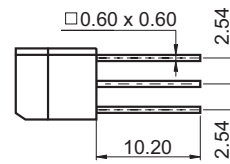
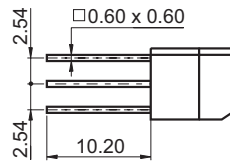
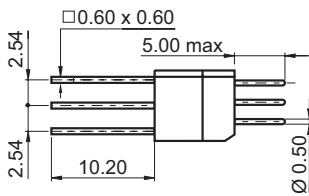

Wire wrap (3 wrapping levels)

Ref: **51** Ref:  **51**

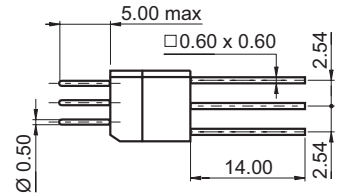
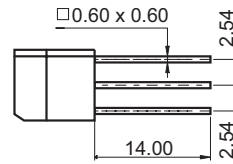
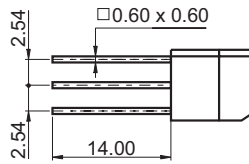
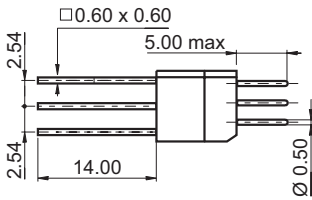

Saver (Male-Male)

Ref: **90**

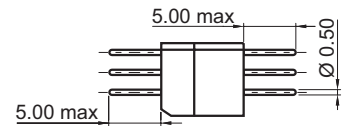
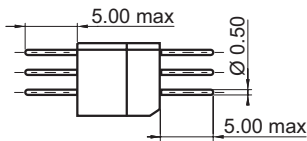

Saver (Female-Male)

Ref: **91** Ref:  **91**

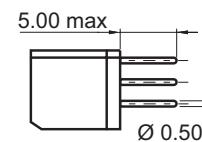
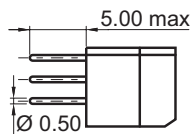

Note: molding A and B need different preparation board details for 90° tail termination.

Dimensions

26 to 98 Contacts

144 to 162 Contacts

One Part (molding A)

90° male plug KMC ... 13 10 ...

90° male receptacle KMC ... 23 10 ...

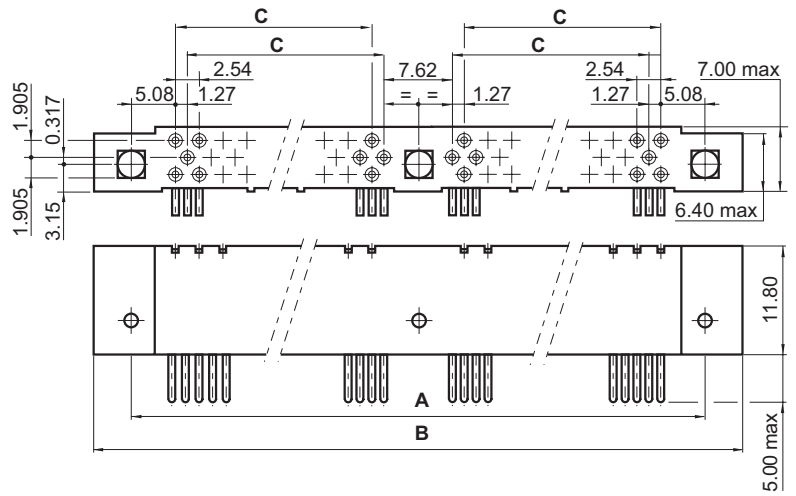
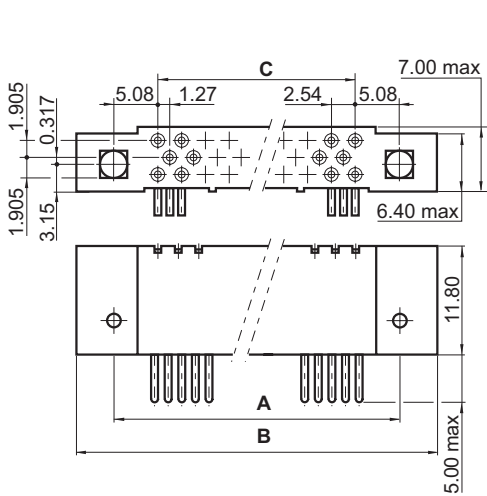

Two parts (molding B)

Female or male receptacle KMC ... 2. ...

Female or male plug KMC ... 1. ...

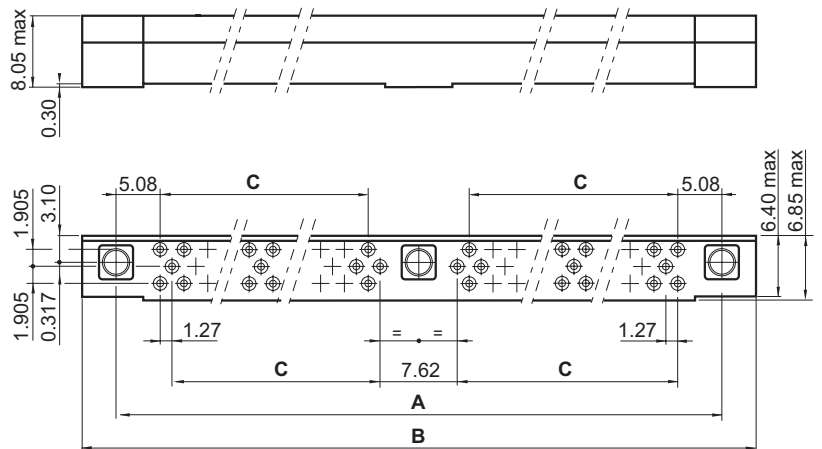
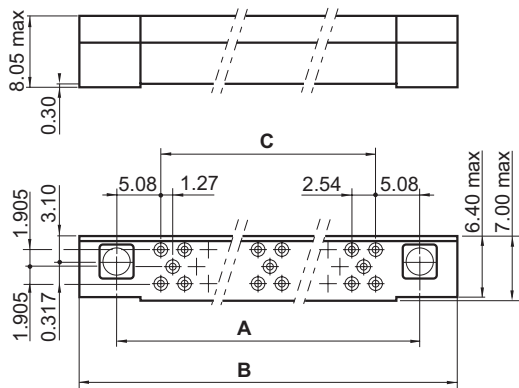

No. of contacts	26	44	62	80	98	144	162
A	30.48	45.72	60.96	76.20	91.44	137.16	152.40
B max	38.50	53.70	69.00	84.20	99.50	145.20	160.40
C	20.32	35.56	50.80	66.04	81.28	58.42	66.04

Male Guide Styles

Polarized transverse mount (molding A)

Ref: 110 Ref:  110

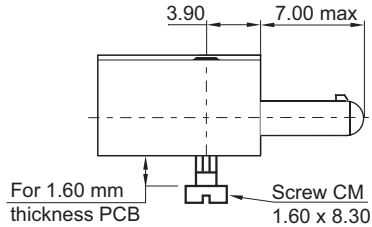

Unpolarized transverse mount (molding A) central guide (KMC 144-162)

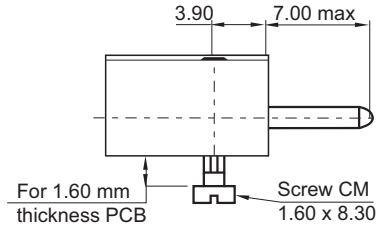

Polarized vertical mount (molding B)

Ref: 111 Ref: 112

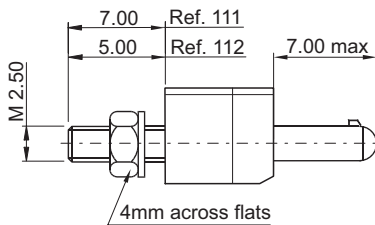

Unpolarized vertical mount (molding B) central guide (KMC 144-162)

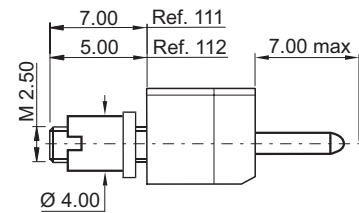

Polarized vertical float mount (molding B)

ref: 113

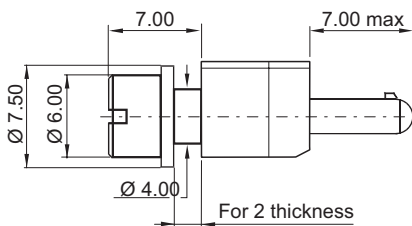

Unpolarized vertical float mount (molding B) central guide (KMC 144-162)

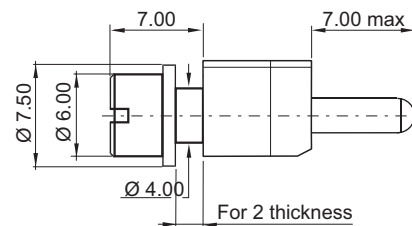

Polarized vertical float mount (molding B)

Ref: 128

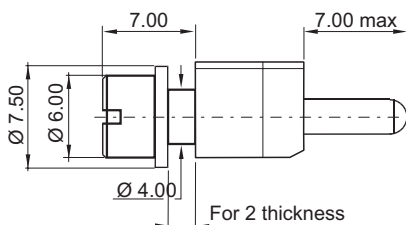

Male Guide Styles

Unpolarized transverse mount
(molding A)

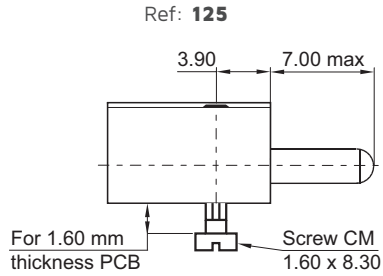

Unpolarized transverse mount
(molding A) central guide (KMC 144-162)

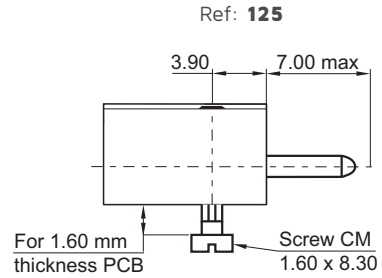

Unpolarized vertical mount
(molding B)

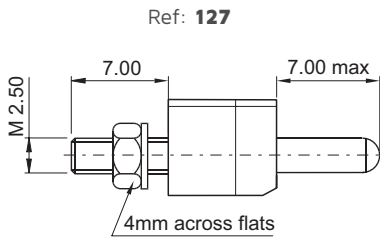

Unpolarized vertical mount
(molding B) central guide (KMC 144-162)

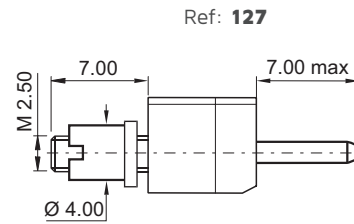

Unpolarized transverse mount
(molding B)

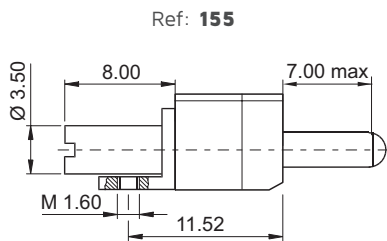

Unpolarized transverse mount
(molding B) central guide (KMC 144-162)

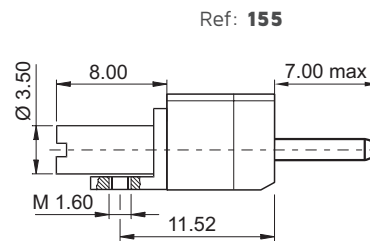

Polarized transverse mount
(molding B)

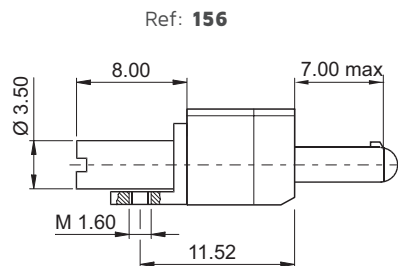

Unpolarized transverse mount
(molding B) central guide (KMC 144-162)

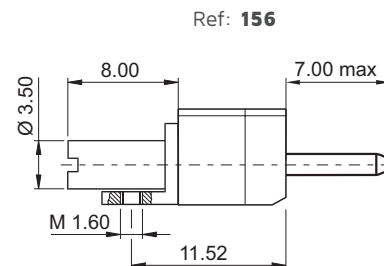

Female Guide Styles

Polarized vertical mount (molding B)

Ref: 121 Ref: 143 Ref: 143

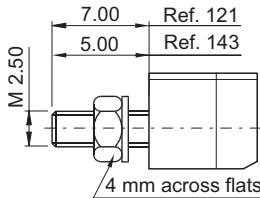

Unpolarized vertical mount (molding B) central guide (KMC 144-162)

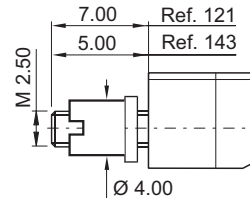

Polarized transverse mount (molding B)

Ref: 124

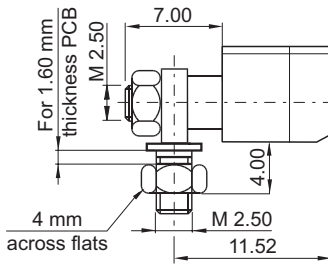

Unpolarized transverse mount (molding B) central guide (KMC 144-162)

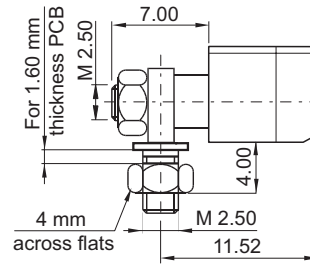

Unpolarized vertical float mount (molding B)

Ref: 123

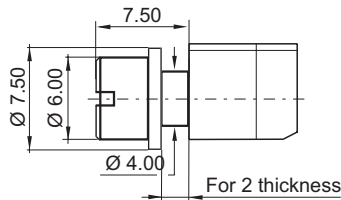

All keying types (molding B)

Ref: 130

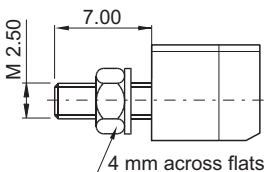

All keying types (molding B) central guide (KMC 144-162)

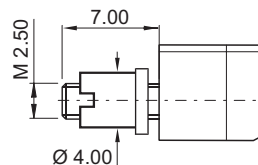

Female Guide Styles

All keying types
(molding B)

Ref: 133

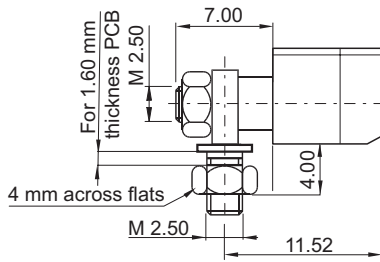

All keying types
(molding B) central guide (KMC 144-162)

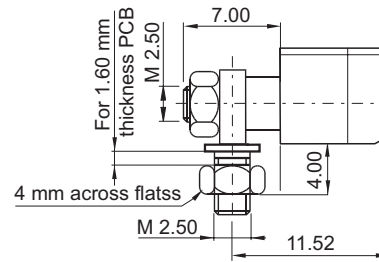

All keying types
(molding B)

Ref: 153

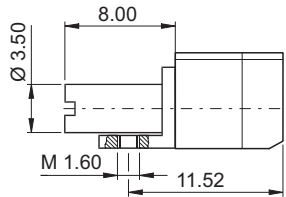

All keying types
(molding B) central guide (KMC 144-162)

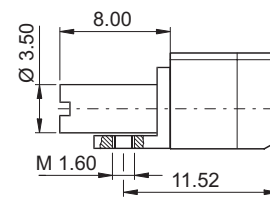

Polarized transverse mount
(molding B)

Ref: 154

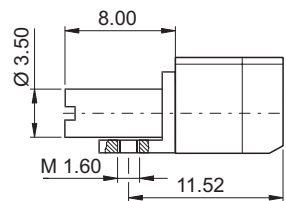

Unpolarized transverse mount
(molding B)
central guide (KMC 144-162)

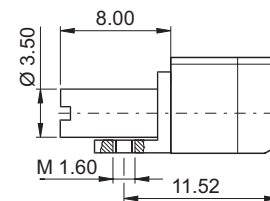

Guide Styles

Female

Unpolarized transverse mount
(molding A)

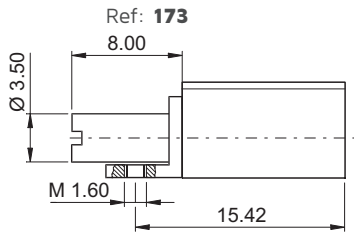

Polarized transverse mount
(molding A)

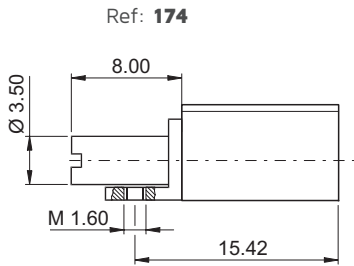

Female

Mass and power contact
(molding B)

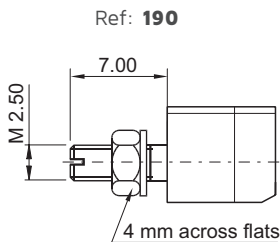

Unpolarized transverse mount
(molding A) central guide (KMC 144-162)

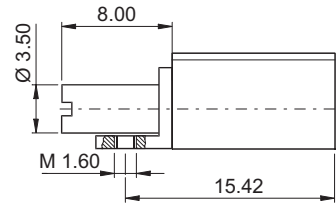

Unpolarized transverse mount
(molding A) central guide (KMC 144-162)

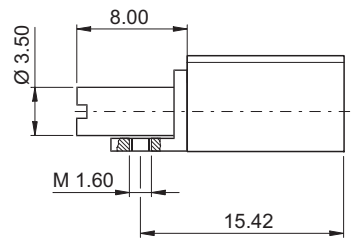

Male

Mass and power contact
(molding A)

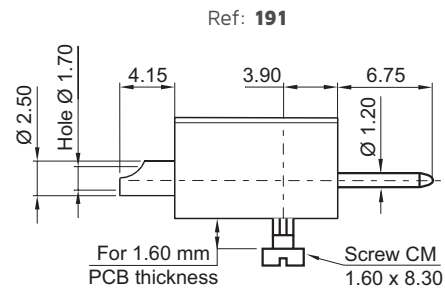

Female - Male

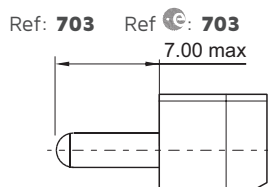

Unpolarized transverse mount
(molding B)

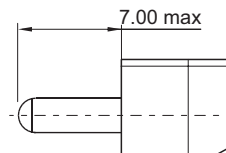

Unpolarized transverse mount
(molding B) central guide (KMC 144-162)

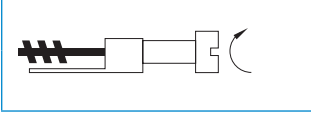
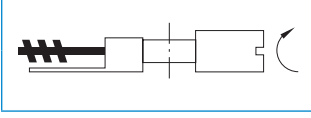
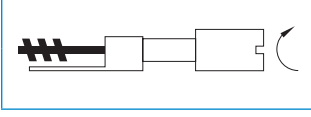
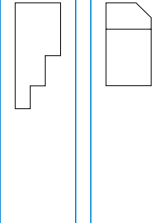
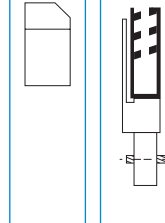
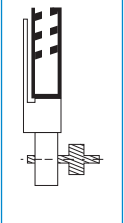
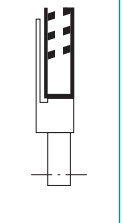
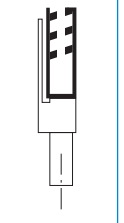

Locking Device Compatibility chart

						A	Molding
						B	
							206
							205
							201
					Male locking devices		
A	B				Female locking devices		
Molding		204	203	202/207			

Compatible

Note: the connector must be fitted with its locking devices before soldering on the PCB (straight through board solder):

- Connector on PCB: impossibility to change the keying.
 - If you need to change the keying:
 - pierce PCB through $\varnothing 3.70$, fixing devices
 - use 054826.000R shouldered washer
- } (for 202 and 207)

Locking Styles

Male

Jackscrew, free connector (molding B)

Ref: **201** Ref: **201**

For **KMC 144-162** the supplied central guide is Ref: **111**

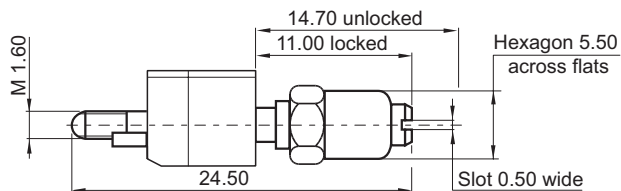

Jackscrew, transverse mount (molding A)

Ref: **205**

For **KMC 144-162** the supplied central guide is Ref: **110**

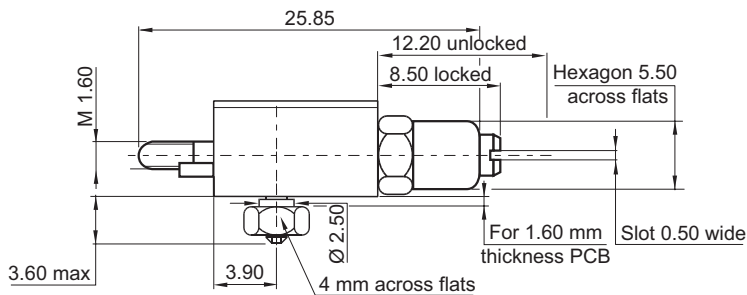

Jackscrew, free connector (molding B)

Ref: **206** Ref: **206**

For **KMC 144-162** the supplied central guide is Ref: **112**

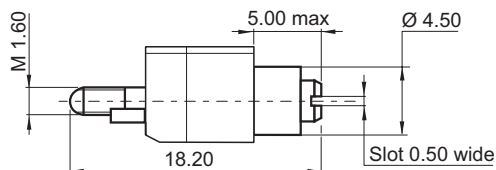

Locking Styles

Female

Non rotating jackscrew, vertical mount (molding B)

Ref: **202** Ref: **202**

For **KMC 144-162** jackscrew 202 the supplied central guide is Ref: **121**

Ref: **207**

jackscrew 207 the supplied central guide is Ref: **143**

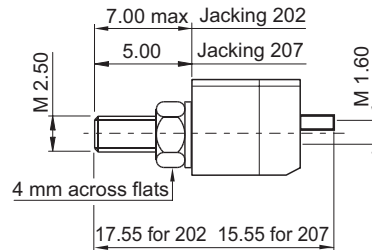

Non rotating jackscrew, transverse mount (molding A)

Ref: **203**

For **KMC 144-162** jackscrew 202 the supplied central guide is Ref: **173**

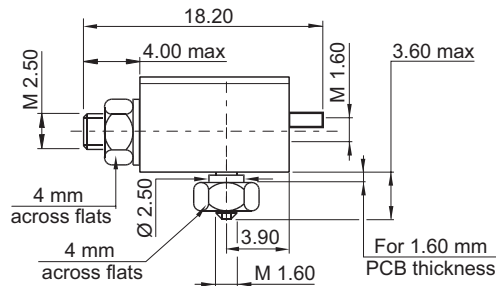

Non rotating jackscrew, transverse mount (molding B)

Ref: **204** Ref: **204**

For **KMC 144-162** the supplied central guide is Ref: **111**

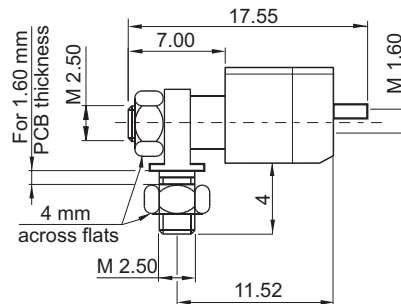

Mating Side Layout View

Molding A

Plug

Receptacle



026

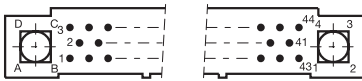
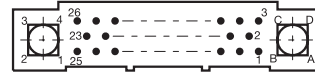

044

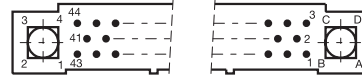

062

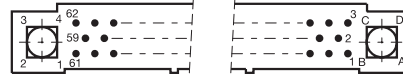

080

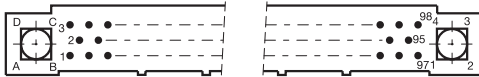
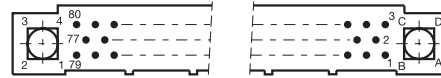

098



144

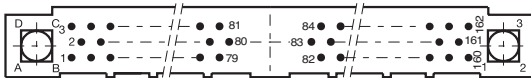
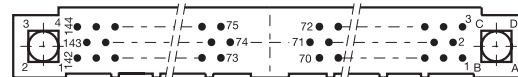

162



Mating Side Layout View

Male plug only

Plug

Receptacle

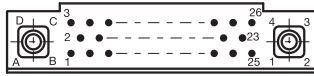

026

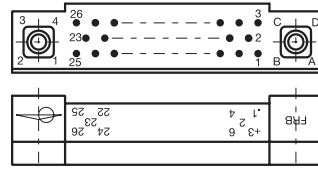

044

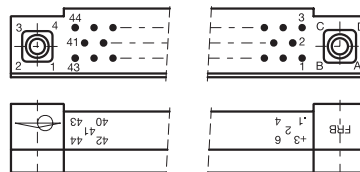

062

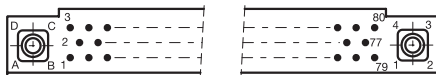
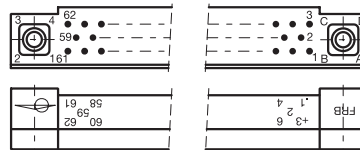

080

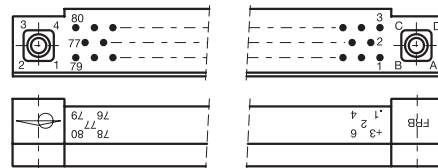

098

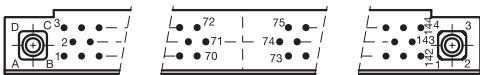
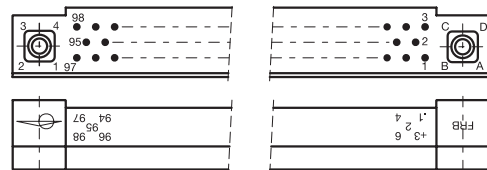

144

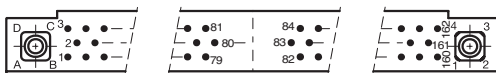
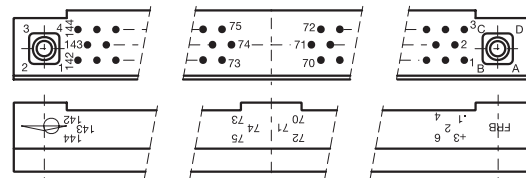

162

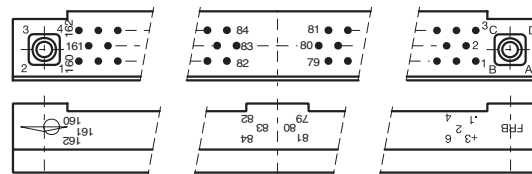

Board Preparation Details

Two Parts (molding B)

26 to 98 contacts

144 to 162 contacts

Mother board

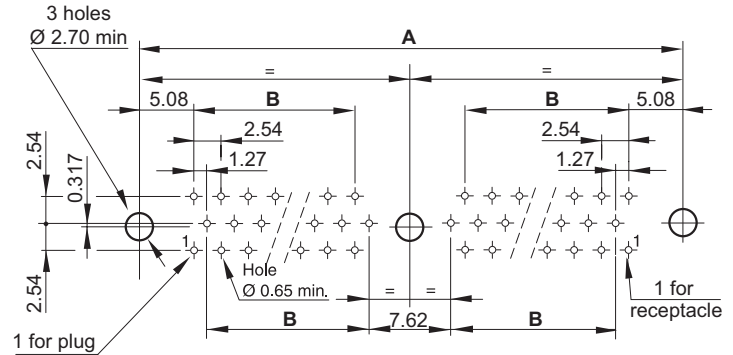
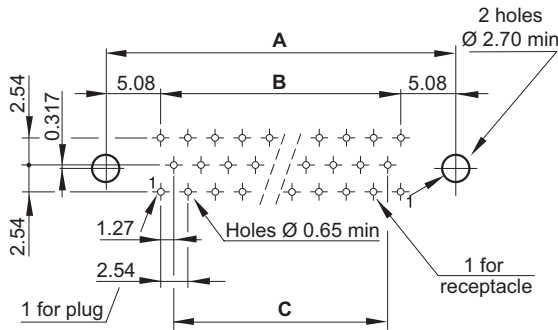

Female or male, plug or receptacle, straight solder terminations 30 or 31

Guide styles: 111 - 112 - 121 - 127 - 130 - 143 - 190

Daughter board

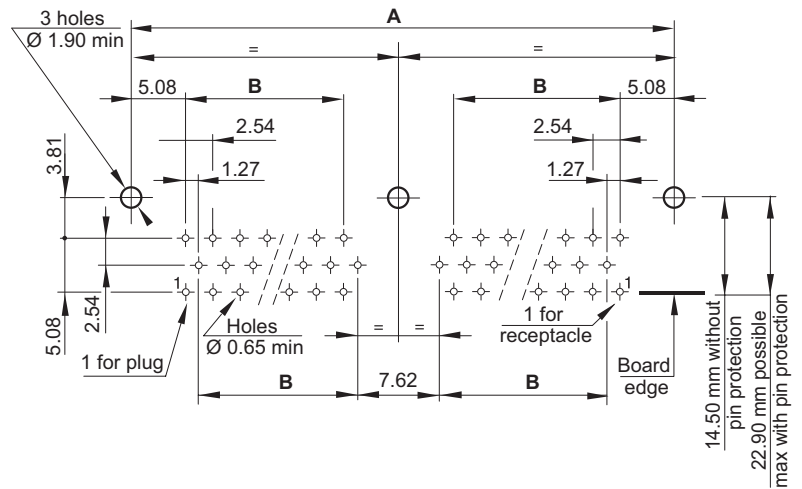
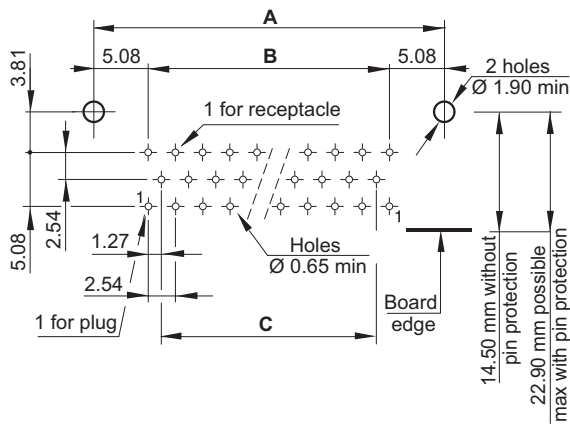

Female or male, plug or receptacle, 90° termination

Guide styles: 153 - 154 - 155 - 156

No. of contacts	26	44	62	80	98	144	162
A	30.48	45.72	60.96	76.20	91.44	137.16	152.40
B	20.32	35.56	50.80	66.04	81.28	58.42	66.04
C	17.78	33.02	48.26	63.50	78.74	-	-

Board Preparation Details

Two Parts (molding B)

26 to 98 contacts

144 to 162 contacts

Daughter board

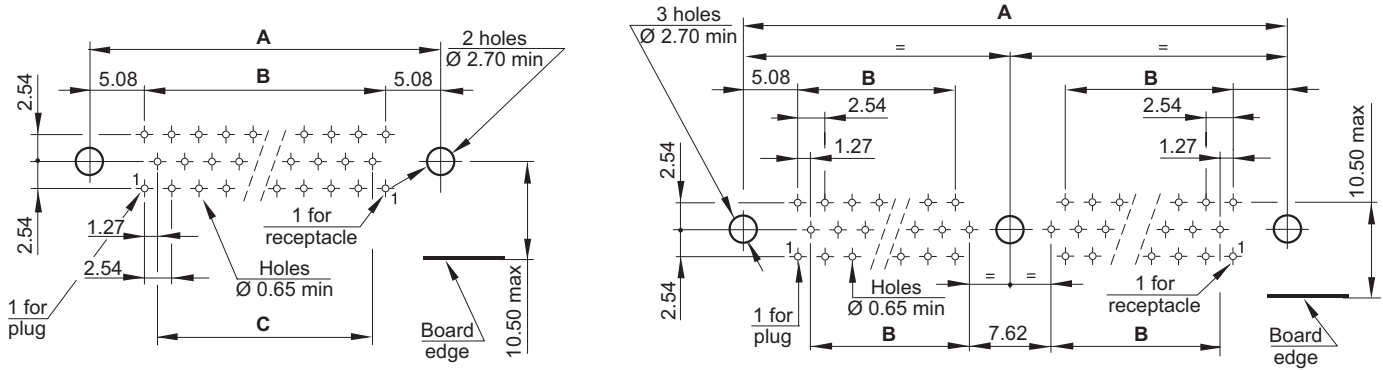

Female or male, plug or receptacle, 90° termination
Guide styles: 124 - 133

No. of contacts	26	44	62	80	98	144	162
A	30.48	45.72	60.96	76.20	91.44	137.16	152.40
B	20.32	35.56	50.80	66.04	81.28	58.42	66.04
C	17.78	33.02	48.26	63.50	78.74	-	-

One Part (molding A)

Daughter board 26 to 98 Contacts

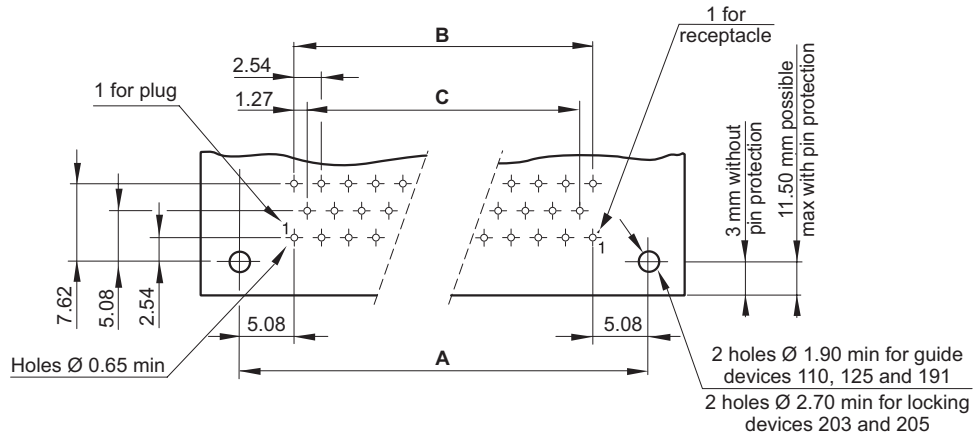

Male, plug or receptacle, 90° termination
Guide styles: 110 - 125 - 191 - 203 - 205

144 to 162 Contacts

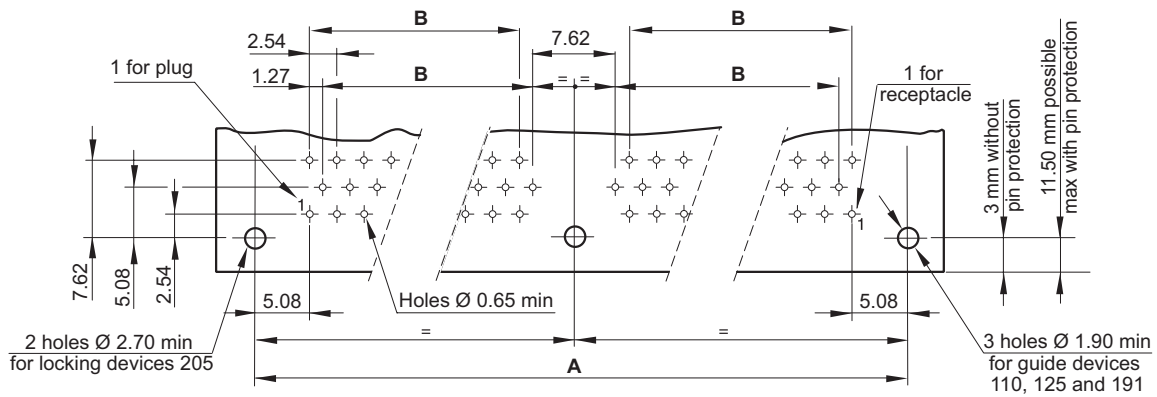

Male, plug or receptacle, 90° termination
Guide styles: 110 - 125 - 191 - 205

No. of contacts	26	44	62	80	98	144	162
A	30.48	45.72	60.96	76.20	91.44	137.16	152.40
B	20.32	35.56	50.80	66.04	81.28	58.42	66.04
C	17.78	33.02	48.26	63.50	78.74	-	-

Board Preparation Details

One Part (molding A)

Daughter board

144 to 162 Contacts

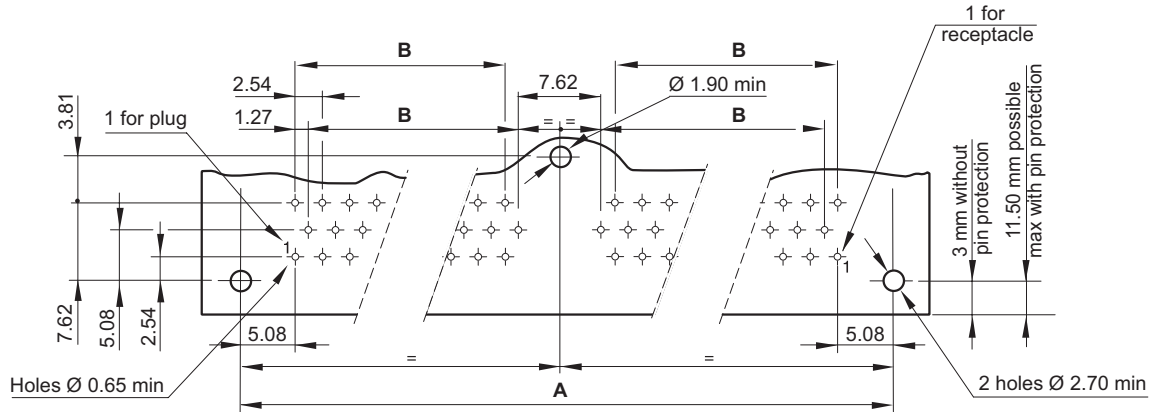

Male, plug or receptacle, 90° termination

Locking styles: 203

No. of contacts	26	44	62	80	98	144	162
A	30.48	45.72	60.96	76.20	91.44	137.16	152.40
B	20.32	35.56	50.80	66.04	81.28	58.42	66.04
C	17.78	33.02	48.26	63.50	78.74	-	-

Panel Preparation Details

Two Parts (molding B)

26 to 98 contacts

144 to 162 contacts

Mother board

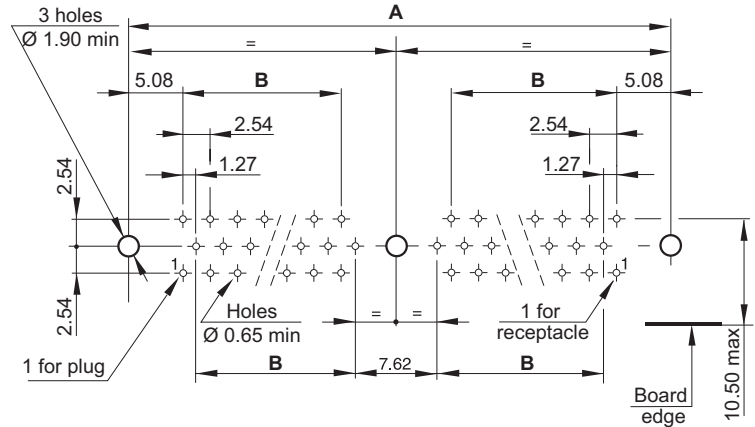
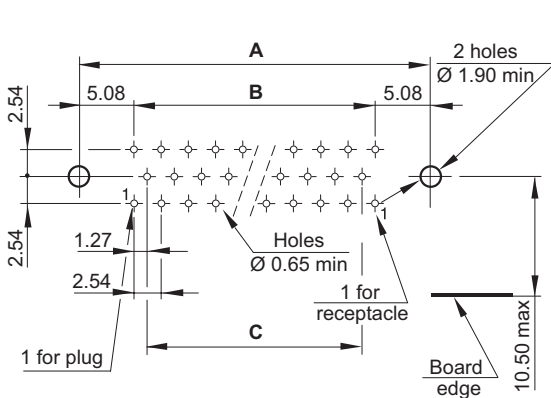

Plug or receptacle, 90° termination
Guide styles: 153 - 154 - 155 - 156

Daughter board

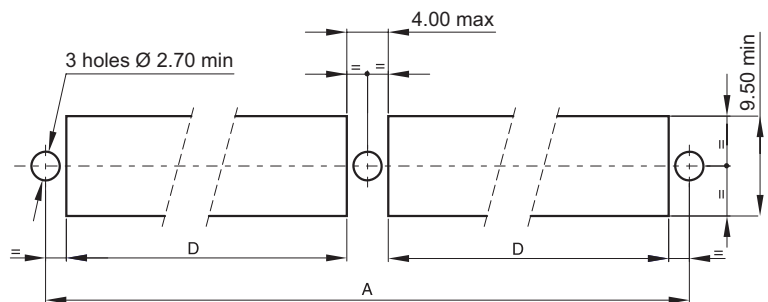
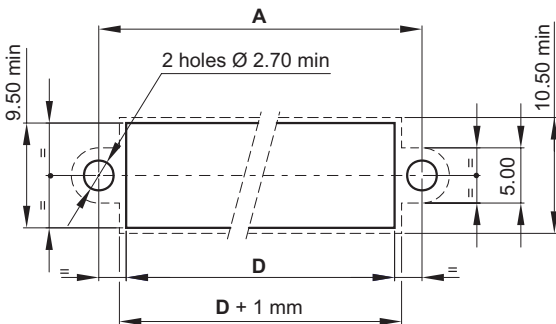

— Fixed mount - - - Float mount (2 mm thickness)

Female or male, plug or receptacle, 90° termination 40 - 50 - 51
Guide styles: 111 - 112 - 121 - 127 -130 - 143 - 190 - (Fixed Mount)

Guide styles: 113 - 123 - 128 - (Float Mount)

Locking Styles: 202 - 207

No. of contacts	26	44	62	80	98	144	162
A	30.48	45.72	60.96	76.20	91.44	137.16	152.40
B	20.32	35.56	50.80	66.04	81.28	58.42	66.04
C	17.78	33.02	48.26	63.50	78.74	-	-
D	25.90	41.20	56.40	71.60	86.90	63.60	71.60

Technical Characteristics

	Signal contact	Power contact	High frequency contact
Contact diameter	HC® Ø 0.50 mm	HC® Ø 2.00 mm	HE 807 type
Number of contact	Up to 162		
Pitch	1.905 mm between rows 1.27 mm between quicuncial contacts	5.08 on 1 row	
Rows	3		

Electrical

Current rating (at 25°C)	3 A max.	15 A	0.5 A
Dielectric withstanding voltage	800 Vrms		
Nominal voltage			180 Vrms 50 Hz
Impedance			50 Ω
Contact resistance	≤8 mΩ	≤2 mΩ	≤10 mΩ
Insulation resistance	104 MΩ (500 Vcc)		≥107 MΩ

Environmental

Temperature range		-55°C to 125°C	
Mating forces		FI ≤8N - FS ≤3N	1N ≤FI/FS ≤5N
Conformity		NF C-UTE C 93-424	

Materials & Platings

Contact	Brass or bronze		
Molding	Glass fiber filled diallyl - Phtalate		
Guides	Stainless steel or nickel plated brass		
	Standard	ESA	
Pin body	0.25 μm gold / 1.27 μm Ni	1.27 μm gold / 1.27 μm Ni (min)	
Socket body	0.25 μm gold / 1.27 μm Ni on active area 1.27 μm Ni on active area	0.25 μm gold / 1.27 μm Ni (min)	
Socket wires	1 μm gold / 0.20 μm Ni	1.27 μm gold / 0.20 μm Ni (min)	

Mechanical

Mating & unmating cycle	5000
Guiding	By two outside guides (2 guiding styles) and one central guide (3 guiding styles)
Keying	By rotating of outside polarized guides (up to 16 keying)

How To Order

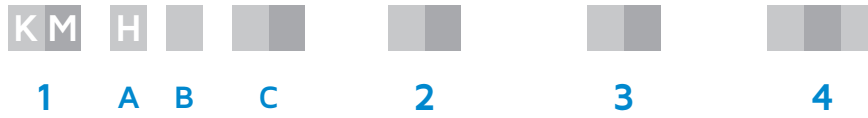

<p>1 Type</p>	<p>A H Moulding with cavities for special contacts B 3 6 Number of cavities for special contacts C 2 6 4 4 8 0 9 0 Number of signal contacts 0.50 mm</p>																														
<p>2 Molding polarity</p>	<table border="1"> <thead> <tr> <th colspan="2">NF C-UTE C 93-424 SPACE GRADE</th> <th colspan="2">NF C-UTE C 93-424 SPACE GRADE</th> <th colspan="2">NF C-UTE C 93-424 SPACE GRADE</th> </tr> </thead> <tbody> <tr> <td>12</td><td>54</td><td>1A</td><td>-</td><td>26</td><td>46</td> </tr> <tr> <td>13</td><td>55</td><td>1B</td><td>-</td><td>27</td><td>47</td> </tr> <tr> <td>16</td><td>56</td><td>22</td><td>44</td><td>2A</td><td>-</td> </tr> <tr> <td>17</td><td>57</td><td>23</td><td>45</td><td>2B</td><td>-</td> </tr> </tbody> </table> <p>Female plug Tinned female plug** Tinned female receptacle* Male plug Tinned male plug** Tinned male receptacle* Tinned female plug* Female receptacle Tinned female receptacle** Tinned male plug* Male receptacle Tinned male receptacle**</p>	NF C-UTE C 93-424 SPACE GRADE		NF C-UTE C 93-424 SPACE GRADE		NF C-UTE C 93-424 SPACE GRADE		12	54	1A	-	26	46	13	55	1B	-	27	47	16	56	22	44	2A	-	17	57	23	45	2B	-
NF C-UTE C 93-424 SPACE GRADE		NF C-UTE C 93-424 SPACE GRADE		NF C-UTE C 93-424 SPACE GRADE																											
12	54	1A	-	26	46																										
13	55	1B	-	27	47																										
16	56	22	44	2A	-																										
17	57	23	45	2B	-																										
<p>3 Termination styles</p>	<p>(see KMC ordering information p. 43)</p>																														
<p>4 Mounting hardware</p>	<p>Guide Styles (see p. 50 to 54) - (Consult us for special guides) - See KMC ordering information p. 43</p> <p>Locking Styles (see p. 56-57) - See KMC ordering information p. 43</p>																														

* For 90° & straight terminations (splicing on PCB)
 ** RoHS conform for 90° & straight terminations (splicing on PCB)

Layout

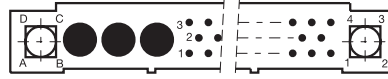

No. of fixings	KMH layout	No. of special contact cavities	No. of signal contacts
2	326	3	26
2	344	3	44
2	380	3	80
3	390	3	90

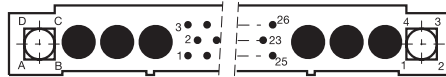

KMH layout	No. of special contact cavities	No. of signal contacts	KMH layout equivalent dimensions
			044
626	6	26	062
			098
			108

Dimensions

26 to 80 Signal Contacts & 3 Special contact cavities

One part plug
(molding A) only KMH 380

Two parts plug & receptacle
(molding B) KMH 326, 344, 380

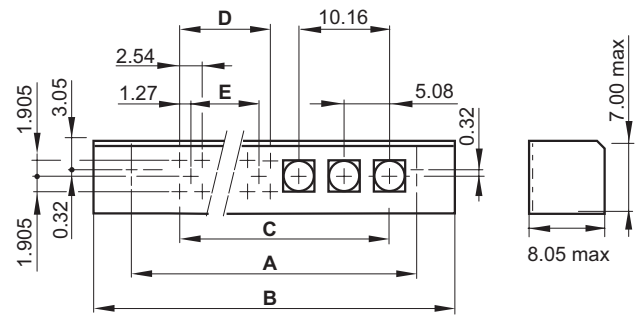
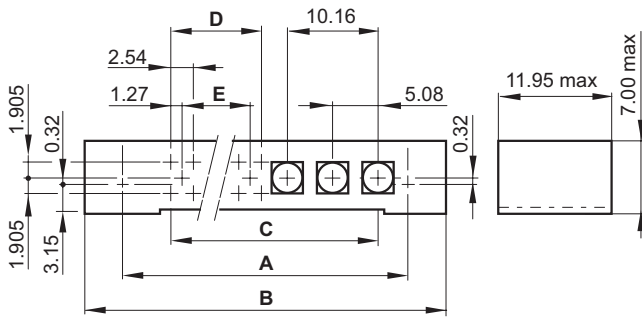

90 Signal Contacts & 3 Special contact cavities

Two parts plug & receptacle (molding B) KMH 390

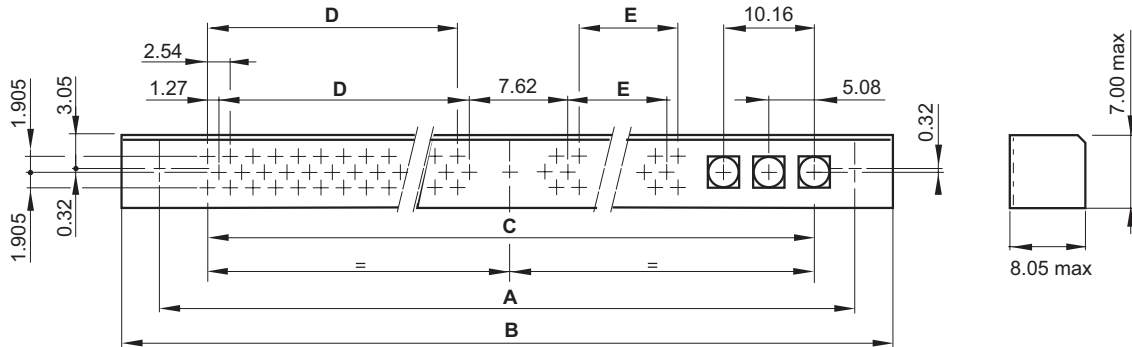

KMH layout	A	B max	C	D	E	KMH layout equivalent dimensions
326	45.72	53.70	35.56	20.32	17.78	044
344	60.96	69.00	50.80	35.56	33.02	062
380	91.44	99.50	81.28	66.04	63.50	098
390	106.68	114.70	96.52	43.18	27.94	108

26 Signal Contacts & 6 Special contact cavities

Two parts plug & receptacle (molding B) with special contact cavities on both extremities KMH 626

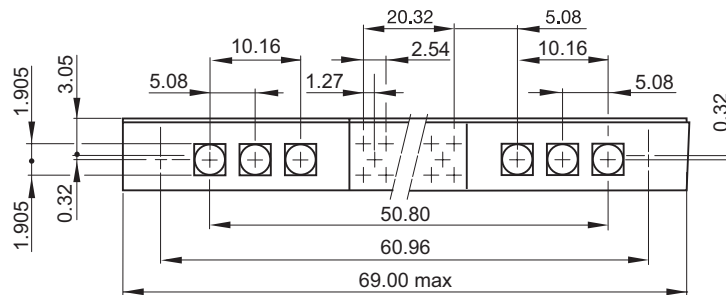

Power & High Frequency Contacts

(NF C-UTE C 93-569)

Example of contact overview (020 084 2- 10 RN1)

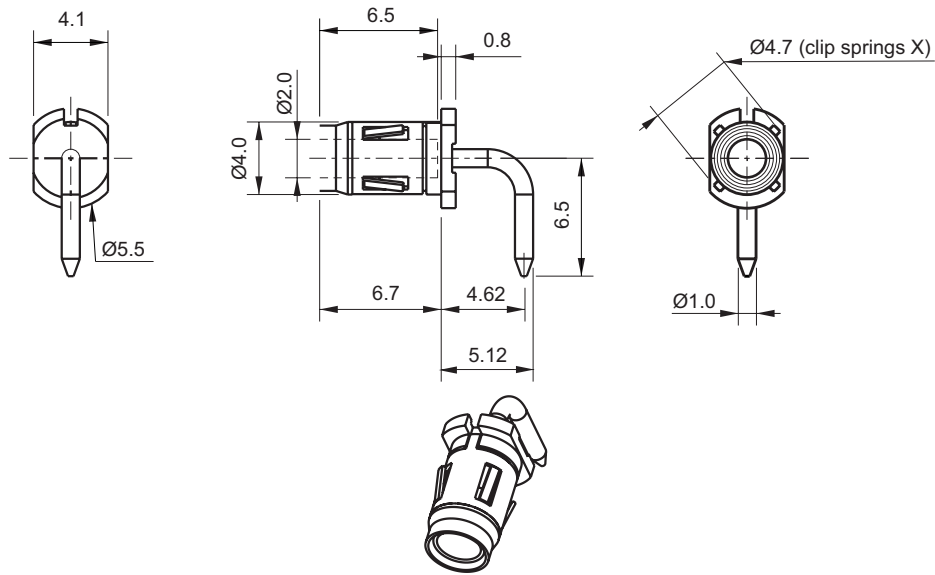

Male	P/N	Female	P/N
90° termination	020 085 1- 10R OG	90° termination	020 084 2- 10R G1
Straight termination	020 087 1- 30R OG	Straight termination	020 056 2- 30R G1
Solder bucket termination	020 091 1- 40R OG	Solder bucket termination	020 060 2- 40R G1

Tools and Accessories

Screwdrivers

Reference	Use	Pinning			Remark
S_____028	- Connector fitted with female guides - "B" molding - Cover's fixing screw for female guide	144	to	162	These three screwdrivers can be delivered in a same packing under the reference S_____036
S_____029	- Connector fitted with male guides - "B" molding - Cover's fixing screw for female guide and screw central fixing on wiring side	144	to	162	
S_____033	- "B" molding - Cover's fixing screws	026	to	162	

Special contact extraction tool

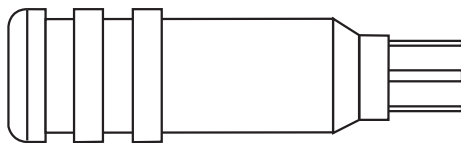

SD.030 00 CX 003

Pin protector

Reference	Use	Guide style
KMC..._____302* Pinning ↙	KMC... 13..110-KMC...23..111 KMC ... 13..111	Polarized male guide
KMC..._____303* Pinning ↙	KMC... 13..125	Unpolarized male guide
KMC..._____304* Pinning ↙	KMC... 23..153	Unpolarized female guide
KMC..._____305* Pinning ↙	KMC... 23..121 KMC... 23..154	Polarized female guide

Note: these 4 references are not available for the 162 contacts version
* Antistatic material

Disclaimer 2023

All of the information included in this catalogue is believed to be accurate at the time of printing. It is recommended, however, that users should independently evaluate the suitability of each product for their intended application and be sure that each product is properly installed, used and maintained to achieve desired results.

Smiths Interconnect makes no warranties as to the accuracy or completeness of the information, and disclaims any liability regarding its use.

Smiths Interconnect reserves the right to modify design and specifications, in order to improve quality, keep pace with technological development or meet specific production requirements.

No reproduction or use without express permission of editorial and pictorial content, in any manner.

Product Portfolio

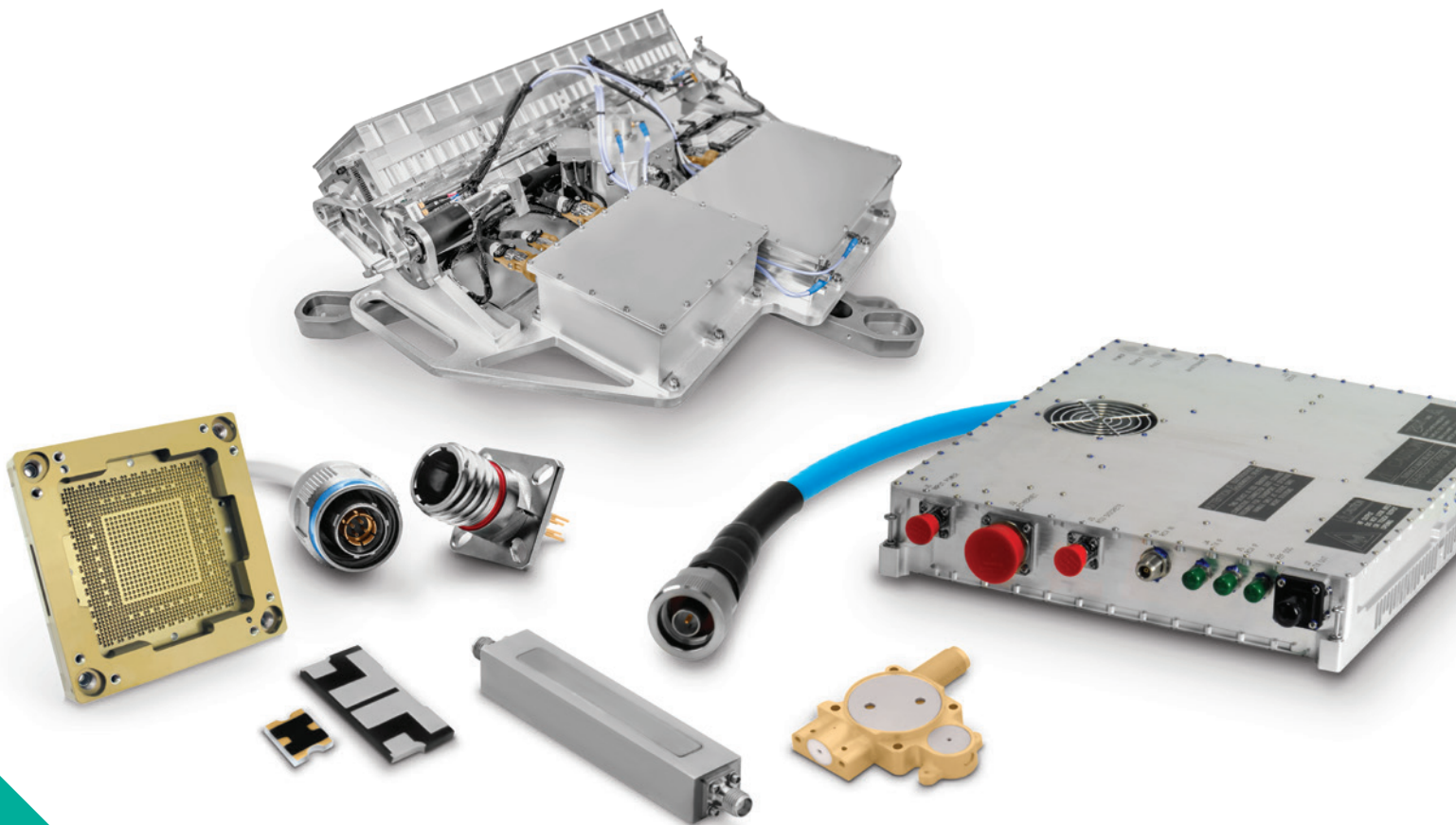

- Antenna Systems
 - Cable Assemblies
 - Connector Solutions
 - Ferrite Components & Assemblies
 - RF Filter Components & Assemblies
 - Integrated Microwave Assemblies
 - Millimeter-Wave Solutions
 - RF Components
 - Test Sockets and WLCSP Probe Heads
 - Time & Frequency Systems

Worldwide Support

Connectors

Americas

Sales

connectors.uscsr@smithsinterconnect.com

Technical Support

connectors.ustechsupport@smithsinterconnect.com

Europe

Sales

connectors.emeacsr@smithsinterconnect.com

Technical Support

connectors.emeatechsupport@smithsinterconnect.com

Asia

Sales

asiacsr@smithsinterconnect.com

Technical Support

asiatechsupport@smithsinterconnect.com

Fiber Optics & RF Components

Americas

Sales

focom.uscsr@smithsinterconnect.com

Technical Support

focom.techsupport@smithsinterconnect.com

Europe

Sales

focom.emeacsr@smithsinterconnect.com

Technical Support

focom.techsupport@smithsinterconnect.com

Asia

Sales

focom.asiacsr@smithsinterconnect.com

Technical Support

focom.techsupport@smithsinterconnect.com

Semiconductor Test

Americas

Sales

semi.uscsr@smithsinterconnect.com

Technical Support

semi.techsupport@smithsinterconnect.com

Europe

Sales

semi.emeacsr@smithsinterconnect.com

Technical Support

semi.techsupport@smithsinterconnect.com

Asia

Sales

semi.asiacsr@smithsinterconnect.com

Technical Support

semi.techsupport@smithsinterconnect.com

RF/MW Subsystems

Americas, Europe & Asia

Sales

subsystems.csr@smithsinterconnect.com

Technical Support

subsystems.techsupport@smithsinterconnect.com

Connecting Global Markets

more > [smithsinterconnect.com](https://www.smithsinterconnect.com) | [in](#) [twitter](#) [youtube](#)